



AGENDA CITY COUNCIL MEETING

[City of Forest Lake - Link to Meeting Livestream](#)

Forest Lake City Center: Council Chambers
Forest Lake, Minnesota

January 12, 2026, 6:00 PM

1. Call to Order
2. Roll Call
3. Pledge of Allegiance
4. Approve the Agenda (Action)
5. Awards and Presentations
 - a. 2026 Lakes Area TV Budget – Paul Peterson, LATV Access Coordinator
 - b. Annual Parks and Recreation Report – Kyle Young/Don Theisen
6. Open Forum - Citizen Petitions, Requests and Concerns: Please sign in at the front table. *The Open Forum is available for residents to express personal opinions for any item of business. Please limit your comments to three (3) minutes.*
7. Consent Agenda Considerations (Action Items)*
 - a. City Invoices
 - i. General Invoices
 - ii. Airport Invoices
 - b. November 10, 2025, Regular Council Meeting Minutes
 - c. November 17, 2025, Council Workshop Minutes
 - d. November 24, 2025, Council Meeting Minutes
 - e. Resolution 01-12-26-01: 2026 Annual Appointments and Designations
 - f. Resolution 01-12-26-02: Issuance of New Tobacco License
 - g. Resolution 01-12-26-03: Approval of 02/01/2026 – 01/31/2027 Licenses
 - h. Resolution 01-12-26-04: Accepting Veterans Memorial Project Donations
 - i. Resolution 01-12-26-05: Accepting Donation - Hometown Holiday Volunteers
 - j. Resolution 01-12-26-06: Accepting Donation – Hometown Holiday Sponsors
 - k. 2026 – 2028 Collective Bargaining Agreement: LELS #111

- l. MOA with AFSCME: New Position: Deputy Clerk
- m. Position Description Approval: Deputy Fire Chief
- n. Hiring Recommendation: Police Administrative Assistant
- o. Rotary Club Fee Waiver Request
- p. Accept Resignation of the Police Chief and Declare a Vacancy at that position
- q. Accept Resignation of Accounting Manager
- r. Eureka Avenue Improvements – Contractor’s Request for Payment No. 1
- s. Suite Living aka DigniCare – Final Project Acceptance
- t. City Licenses and Permits Recommendations
 - i. Gambling Permit Applications
 - ii. Temporary Liquor Licenses

*Council may remove any item from the consent agenda for specific consideration.

- 8. Regular Agenda (Action Items)
 - a. Zoning Text Amendment: Wireless Communication Towers – Abbi Wittman
 - i. Public Hearing
 - ii. Ordinance 765
 - iii. Resolution 01-12-26-07
 - b. Spikes and Houles Phase II – Amended Site Plan & PUD Preliminary and Final Plan – Abbi Wittman
 - i. Resolution 01-12-26-08 – Prelim Plat and PUD
 - ii. Resolution 01-12-26-09 – Site Plan Approval
 - c. MNDOT Aviation Grant Awards – Mark Statz
 - i. Runway
 - ii. Taxiway
 - iii. Apron
 - d. Logos on Street Name Blades – Dave Adams
- 9. Discussion
 - a. None
- 10. Staff Updates
- 11. Mayor and City Council Updates
- 12. Adjourn

01/08/2026

INVOICE GL DISTRIBUTION REPORT FOR FOREST LAKE
 EXP CHECK RUN DATES 12/22/2025 - 01/12/2026
 BOTH JOURNALIZED AND UNJOURNALIZED
 PAID

GL Number	Invoice Line Desc	Vendor	Invoice Description	Amount	Check #
Check 118624					
101-43-3100-54040	REPAIR & MAINT EQUIPMENT	A-1 TIRE SERVICE	FIRESTONE TRANSFORCE AT2	1,225.04	118624
101-43-3100-54040	REPAIR & MAINT EQUIPMENT	A-1 TIRE SERVICE	FIRESTONE TRANSFORCE AT2	1,323.24	118624
101-43-3100-54040	REPAIR & MAINT EQUIPMENT	A-1 TIRE SERVICE	FIRESTONE DESTINATION A/T2	<u>2,964.72</u>	118624
		Total For Check 118624		<u>5,513.00</u>	
Check 118625					
101-42-2100-54040	REPAIR & MAINT EQUIPMENT	AMERICAN IMPORTS	SQUAD 2208 - FRONT & REAR BRAKES & CHECK ENGINE LIGHT IS ON	1,090.03	118625
101-42-2100-54040	REPAIR & MAINT EQUIPMENT	AMERICAN IMPORTS	SQUAD 2509 - MOUNT & BALANCE FOUR TIRES	737.99	118625
101-42-2100-54040	REPAIR & MAINT EQUIPMENT	AMERICAN IMPORTS	SQUAD 2115 - RADIATOR/COOLING SYSTEM PRESSURE TEST	869.52	118625
101-42-2100-54040	REPAIR & MAINT EQUIPMENT	AMERICAN IMPORTS	SQUAD 2104 - BRAKE INSPECTION - SERVICE/ERROR MESSAGE DISPLAYED FOR PARKING BRAKE SYSTEM	87.44	118625
101-42-2100-54040	REPAIR & MAINT EQUIPMENT	AMERICAN IMPORTS	SQUAD 2012 - CHANGE OIL & TIRE ROTATION	52.03	118625
101-42-2100-54040	REPAIR & MAINT EQUIPMENT	AMERICAN IMPORTS	SQUAD 2012 - REPLACE VALVE STEM- LEFT FRONT AND LEFT REAR	<u>64.62</u>	118625
		Total For Check 118625		<u>2,901.63</u>	
Check 118626					
101-00-0000-22400	BDE-0057	BENJAMIN & KRISTYN STEPHENS	BD BOND REFUND - DEMOLITION ESCROW PB12285	<u>16,000.00</u>	118626
		Total For Check 118626		<u>16,000.00</u>	
Check 118627					
101-42-2100-54370	MISCELLANEOUS	BLUUM OF MINNESOTA LLC	21863 - REACH SIGNAGE - VIDEO SOURCE SOLUTION	<u>886.04</u>	118627
		Total For Check 118627		<u>886.04</u>	
Check 118629					
211-00-0000-22410	BD-0037	CAMPBELL PROPERTIES	BD BOND REFUND	<u>8,125.00</u>	118629
		Total For Check 118629		<u>8,125.00</u>	
Check 118630					
101-00-0000-22400	BEL-0210	CAPSTONE HOMES INC	BD BOND REFUND EROSION-LANDSCAPE ESCROW RELEASE PB12190	2,000.00	118630
101-00-0000-22400	BEL-0205	CAPSTONE HOMES INC	BD BOND REFUND EROSION-LANDSCAPE ESCROW RELEASE PB12133	2,000.00	118630
101-00-0000-22400	BEL-0215	CAPSTONE HOMES INC	BD BOND REFUND EROSION-LANDSCAPE ESCROW RELEASE PB12316	2,000.00	118630
101-00-0000-22400	BEL-0216	CAPSTONE HOMES INC	BD BOND REFUND EROSION-LANDSCAPE ESCROW PB12315	<u>2,000.00</u>	118630
		Total For Check 118630		<u>8,000.00</u>	
Check 118631					
101-42-2100-52210	REPAIR & MAINT SUPPLIES	CAR WASH PARTNERS LLC	MISTER CAR WASH NOVEMBER 2025 SERVICES	<u>59.40</u>	118631
		Total For Check 118631		<u>59.40</u>	
Check 118632					
101-00-0000-22420	BZCP-0002	CHELDON FRANK	BD BOND REFUND - PROJECT SHLAYBA	<u>500.00</u>	118632
		Total For Check 118632		<u>500.00</u>	
Check 118633					
101-00-0000-22420	BZPP-0003	CHRISTOPHER GAIOVNIK	BD BOND REFUND - PROJECT GAIOVNIK ESTATES	<u>530.00</u>	118633
		Total For Check 118633		<u>530.00</u>	
Check 118634					
101-43-3100-52100	OPERATING SUPPLIES	CINTAS CORPORATION	REFILLS FOR FIRST AID KITS	39.54	118634
101-43-3100-52100	OPERATING SUPPLIES	CINTAS CORPORATION	REFILLS FOR FIRST AID KITS	127.49	118634
101-43-3180-52130	UNIFORMS & CLOTHING	CINTAS CORPORATION	UNIFORM & CLOTHING - M.WELSH	86.45	118634

		Total For Check 118644		<u>9,769.56</u>	
Check 118645					
631-00-0000-20800	OVERPAYMENT	EVERGREEN RIDGE TOWNHOMES III	UB refund for account: 7105512	<u>2,969.42</u>	118645
		Total For Check 118645		<u>2,969.42</u>	
Check 118646					
101-41-1940-53350	CONTRACT SERVICES	FASTENAL COMPANY	ROAD RUNNER 50# BAG	700.00	118646
101-42-2200-52100	OPERATING SUPPLIES	FASTENAL COMPANY	1GAL JUG DEGREASER & VEHICLE CLEANER 1GAL & 13.5OZWAX&TARREMOVER	<u>156.17</u>	118646
		Total For Check 118646		<u>856.17</u>	
Check 118647					
631-49-9420-52100	OPERATING SUPPLIES	FERGUSON WATERWORKS #2518	TYLER VLV BX LID WTR DOM & 6 BX BSE 6860 DOM & 24 VLV BX EXT SCRWB 60 DOM & 26 SC VLV BX TOP SECT DOM	4,614.24	118647
631-49-9420-52100	OPERATING SUPPLIES	FERGUSON WATERWORKS #2518	RITE HITE ADPT SLIP TYPE	<u>414.24</u>	118647
		Total For Check 118647		<u>5,028.48</u>	
Check 118648					
101-43-3100-52100	OPERATING SUPPLIES	FOREST LAKE ACE HARDWARE	BATTERY ALKALINE AA 20PK	47.98	118648
101-43-3180-52100	OPERATING SUPPLIES	FOREST LAKE ACE HARDWARE	FASTENERS	<u>4.29</u>	118648
		Total For Check 118648		<u>52.27</u>	
Check 118649					
101-00-0000-20710	DUE TO OTHER GOVERNMENTS	FOREST LAKE CABLE COMMISSION	FRANCHISE FEE	7,537.46	118649
101-00-0000-20710	DUE TO OTHER GOVERNMENTS	FOREST LAKE CABLE COMMISSION	FRANCHISE FEE	7,451.77	118649
101-00-0000-20710	DUE TO OTHER GOVERNMENTS	FOREST LAKE CABLE COMMISSION	FRANCHISE FEE	<u>7,343.52</u>	118649
		Total For Check 118649		<u>22,332.75</u>	
Check 118650					
205-43-3150-53070	PROFESSIONAL SERVICES	FOREST LAKE LAKE ASSOCIATION	TRI PARTY AGREEMENT	<u>8,997.16</u>	118650
		Total For Check 118650		<u>8,997.16</u>	
Check 118651					
800-41-1910-53070-EVERTN-463	PROFESSIONAL SERVICES	FRATTALONE COMPANIES INC	HOUSE DEMO - 21164 EVERTON AVE	<u>14,155.00</u>	118651
		Total For Check 118651		<u>14,155.00</u>	
Check 118652					
101-41-1400-53070	PROFESSIONAL SERVICES	GALLAGHER BENEFIT SERVICES INC	DECEMBER 2025 CONSULTING SERVICES	<u>1,200.00</u>	118652
		Total For Check 118652		<u>1,200.00</u>	
Check 118653					
631-49-9440-53110	LOCATES	GOPHER STATE ONE-CALL	FTP TICKETS (246); CANCELLED TICKETS (3); TOTAL BILLABLE TICKETS (243)	164.02	118653
632-49-9490-53110	LOCATES	GOPHER STATE ONE-CALL	FTP TICKETS (246); CANCELLED TICKETS (3); TOTAL BILLABLE TICKETS (243)	<u>164.03</u>	118653
		Total For Check 118653		<u>328.05</u>	
Check 118654					
101-42-2100-52130	UNIFORMS & CLOTHING	GUARDIAN SUPPLY LLC	UNIFORM - H. BELKA (PANTS TORN DURING ROLLOVER INCIDENT)	<u>79.99</u>	118654
		Total For Check 118654		<u>79.99</u>	
Check 118655					
631-49-9420-52160	CHEMICALS & TESTING	HACH COMPANY	BENCH PLUS DR900:1:9385100 & BENCH PLUS SL1000:1:9430000	<u>998.17</u>	118655
		Total For Check 118655		<u>998.17</u>	
Check 118656					
203-45-5200-53050-128559-001	PROFESSIONAL SERVICES	HARDWOOD CREEK NURSERY INC	BELTZ PARK - ELM NEW HARMONY IN GROUND & ELM ACCOLADE IN GROUND	<u>3,500.00</u>	118656
		Total For Check 118656		<u>3,500.00</u>	

Check 118657 631-49-9420-52160	CHEMICALS & TESTING	HAWKINS INC Total For Check 118657	CHLORINE EPA 7870-2	<u>1,149.39</u> 1,149.39	118657
Check 118658 101-43-3100-54040 101-43-3100-54040	REPAIR & MAINT EQUIPMENT REPAIR & MAINT EQUIPMENT	I - STATE TRUCK CENTER I - STATE TRUCK CENTER Total For Check 118658	CLAMP DRUM-BRAKE, 1H O66TT 878 974 13 & CLAMP & REMAN SHOE KIT	38.02 <u>1,105.14</u> 1,143.16	118658 118658
Check 118659 205-43-3190-53070 631-49-9490-53070 632-49-9490-53070	SURFACE ADM/PROFESSIONAL SERVICES SEWER ADM/PROFESSIONAL SERVICE SEWER ADM/PROFESSIONAL SERVICES	IMPACT IMPACT IMPACT Total For Check 118659	MONTHLY PORTAL FEE MONTHLY PORTAL FEE MONTHLY PORTAL FEE	22.50 101.25 <u>101.25</u> 225.00	118659 118659 118659
Check 118660 101-00-0000-22400	BEL-0064	JAGGED EDGE BUILDERS Total For Check 118660	BD BOND REFUND EROSION-LANDSCAPE ESCROW RELEASE PB10073	<u>2,000.00</u> 2,000.00	118660
Check 118661 101-00-0000-22420	BZLL-0003	KELLY HOUFER Total For Check 118661	BD BOND REFUND - PROJECT HOUFER LOT LINE ADJUSTMENT	<u>250.00</u> 250.00	118661
Check 118662 101-41-1940-54010 631-49-9420-54040 632-49-9450-54040 632-49-9450-54040 632-49-9450-54040 632-49-9450-54040 632-49-9450-54040	REPAIR & MAINT-BUILDINGS REPAIR & MAINT EQUIPMENT REPAIR & MAINT EQUIPMENT REPAIR & MAINT EQUIPMENT REPAIR & MAINT EQUIPMENT REPAIR & MAINT EQUIPMENT REPAIR & MAINT EQUIPMENT	KODIAK POWER SOLUTIONS KODIAK POWER SOLUTIONS KODIAK POWER SOLUTIONS KODIAK POWER SOLUTIONS KODIAK POWER SOLUTIONS KODIAK POWER SOLUTIONS KODIAK POWER SOLUTIONS Total For Check 118662	CITY CENTER - REPLACE ENGINE AIR FILTER PLANT 2 WELL 4 - REPLACE BATTERIES & CLEAN BATTERY CABLE ENDS & PERFORM NECESSARY SYSTEM RESETS LS 7T - REPLACE THROTTLE BODY ASSEMBLY AND STARTER & CLEAR DIAGNOSTIC CODES AND PERFORM NECESSARY SYST LS 10 - SEND IN OIL SAMPLE FOR ANALYSIS & SAMPLE WAS TAKEN DURING THE ANNUAL SERVICE ON 11/13/25 LS 12 - REPLACE ALL 3 CURRENT TRANSFORMERS & RUN GENERATOR TO VERIFY PROPER OPERATION LS 4 - PERFORM COOLING SYSTEM MAINTENANCE - CSM INCLUDES REPLACE THERMOSTAT AND RELATED GASKETS/SEALS LS 19 - PERFORM COOLING SYSTEM MAINTENANCE - CSM INCLUDES REPLACE THERMOSTAT AND RELATED GASKETS/SEAL	156.05 989.96 1,491.66 55.00 1,409.07 1,898.80 <u>1,907.97</u> 7,908.51	118662 118662 118662 118662 118662 118662 118662
Check 118663 631-49-9420-54010	REPAIR & MAINT-BUILDINGS	KRAMER MECHANICAL Total For Check 118663	1850 8TH ST SE - FURNACE NOT WORKING - FURNACE HAD A ERROR CODE FOR HIGH LIMIT & CHECKED THE BLOWER	<u>297.50</u> 297.50	118663
Check 118664 101-42-2100-53060	MEDICAL	LAKEVIEW HOSPITAL Total For Check 118664	LEGAL BLOOD DRAWS	<u>50.00</u> 50.00	118664
Check 118665 101-41-1910-53080	SEMINARS & TRAINING	LEADERSHIP GROWTH GROUP LLC Total For Check 118665	2026 LEADERSHIP GROWTH GROUP SERIES	<u>600.00</u> 600.00	118665
Check 118666 101-45-5120-54380	PARKS PROGRAMS/ENTERTAINMENT	LET'S GO FISHING FOREST LAKE Total For Check 118666	LET'S GO FISHING - FOREST LAKE STARTUP SUPPORT	<u>10,000.00</u> 10,000.00	118666
Check 118667 101-43-3180-52100	OPERATING SUPPLIES	LINDE GAS & EQUIPMENT INC Total For Check 118667	INDUSTRIAL ACETYLENE IND HIGH PRESSURE > 100CF - RENTAL 10/20/2025 TO 11/20/2025	<u>210.69</u> 210.69	118667
Check 118668 101-42-2100-53060 101-43-3100-53060	MEDICAL MEDICAL	M HEALTH FAIRVIEW M HEALTH FAIRVIEW	MULTIPLE TESTS - A. LEWERENZ MULTIPLE TESTS - M. SWENSON & M. WELSH	574.04 116.00	118668 118668

		Total For Check 118668		<u>690.04</u>	
Check 118669					
101-41-1601-53040	LEGAL SERVICES	MADDEN GALANTER HANSEN ATTORNEYS AT Total For Check 118669	SERVICES RENDERED - 11/1/2025 THROUGH 11/30/2025	<u>5,906.75</u> 5,906.75	118669
Check 118670					
211-00-0000-22410	BD-0031	MARIE DICKOVER Total For Check 118670	BD BOND REFUND - PROJECT EVE GENESIS PZ22-1150	<u>500.00</u> 500.00	118670
Check 118671					
101-00-0000-22400	BDE-0047	MATT & JENNY CURREN Total For Check 118671	BD BOND REFUND DEMOLITION ESCROW	<u>3,125.00</u> 3,125.00	118671
Check 118672					
101-43-3100-52100	OPERATING SUPPLIES	MENARDS	DAWN ULTRA ORIGINAL 70OZ & TEARNCLEAN MF ROLL 40PK & 9PK HEAVY DUTY SPONGES	27.47	118672
101-45-5200-52100	OPERATING SUPPLIES	MENARDS	70L (WW) C6 FACETED & 70L (RED) C6 FACETED & L00L (PW) HNGST MS ICICLE & L00L (WW) HNGST MS ICICLE	170.85	118672
101-45-5200-52100	OPERATING SUPPLIES	MENARDS	L00L (PW) HNGST MS ICICLE	38.97	118672
101-45-5200-52100	OPERATING SUPPLIES	MENARDS	RETURN - L00L (PW) HNGST MS ICICLE & L00L (PW) HNGST MS ICICLE	(25.98)	118672
101-45-5200-52100	OPERATING SUPPLIES	MENARDS	PLAID TREE SKT W REINDEER & PLUSH TREE SKIRT & SAND IN A TUBE	131.33	118672
631-49-9420-52100	OPERATING SUPPLIES	MENARDS	20' FG EXT LADDER TLA & 10' FG STEP LADDER TLA & 6 FG STEP LADDER TLA	717.00	118672
631-49-9420-52100	OPERATING SUPPLIES	MENARDS	LT 3PK ASSORTMENT & LOA CHARGER W/50A ES & TOMCAT RODENT STATION & FVP RV MARINE -50F A/F	133.52	118672
631-49-9420-52100	OPERATING SUPPLIES	MENARDS	1-1/2 GALV SPLT RING HNGR	2.58	118672
		Total For Check 118672		<u>1,195.74</u>	
Check 118673					
101-41-1500-53090	COMPUTER SUPPORT	METRO SALES INC Total For Check 118673	RICOH/IM 350F COPIER	<u>91.75</u> 91.75	118673
Check 118674					
101-41-1500-53090	COMPUTER SUPPORT	METRO-INET Total For Check 118674	USER, COMPUTER & EMAIL SUPPORT	<u>23,201.00</u> 23,201.00	118674
Check 118675					
632-49-9450-54410	MET COUNCIL SEWER TREATMENT	METROPOLITAN COUNCIL - ENVIRONMENA Total For Check 118675	WASTE WATER SERVICES DEF REV - JANUARY 2026	<u>168,466.12</u> 168,466.12	118675
Check 118676					
101-42-2200-53090	COMPUTER SUPPORT	MIDCONTINENT COMMUNICATIONS Total For Check 118676	COLUMBUS FIRE SUB STATION DECEMBER 2025	<u>243.19</u> 243.19	118676
Check 118677					
211-43-3135-53070	PROFESSIONAL SERVICES	MIDWEST WETLAND IMPROVEMENTS LLC Total For Check 118677	B0034-0001 MEDIAN REDESIGN:10 - CONST. ADMIN. - PHASE 1	<u>370.75</u> 370.75	118677
Check 118678					
101-42-2100-54330	DUES & SUBSCRIPTIONS	MINNESOTA CHIEFS OF POLICE ASSOCIAT	VOTING DUES - TOTAL NUMBER OF LICENSED OFFICERS: 16-50	513.00	118678
101-42-2200-54330	DUES & SUBSCRIPTIONS	MINNESOTA CHIEFS OF POLICE ASSOCIAT Total For Check 118678	1 MEMBER DUES - ASSOCIATE DUES	<u>225.00</u> 738.00	118678
Check 118679					
101-42-2200-54330	DUES & SUBSCRIPTIONS	MINNESOTA FIRE SERVICE CERTIFICATIO Total For Check 118679	RECERTIFICATION FOR EXPIRING CERTIFICATIONS AS OF 12/7/2025 - TOTAL COUNT 20	<u>525.00</u> 525.00	118679
Check 118680					
631-49-9420-52160	CHEMICALS & TESTING	MINNESOTA VALLEY TESTING LABS	COLIFORM, MF - WATER	157.50	118680

Total For Check 118680				<u>157.50</u>	
Check 118681					
101-42-2200-52210	REPAIR & MAINT SUPPLIES	NAPA AUTO PARTS	NAPA DIESEL EXHAUST FLUID	51.96	118681
101-42-2200-52210	REPAIR & MAINT SUPPLIES	NAPA AUTO PARTS	RV ANTIFREEZE	20.52	118681
101-42-2200-54040	REPAIR & MAINT EQUIPMENT	NAPA AUTO PARTS	18MO WTY BAT & CORE DEPOSIT	366.32	118681
101-43-3100-54040	REPAIR & MAINT EQUIPMENT	NAPA AUTO PARTS	RV ANTIFREEZE	20.52	118681
101-43-3100-54040	REPAIR & MAINT EQUIPMENT	NAPA AUTO PARTS	4 METAL VALVE STEMS	7.49	118681
101-43-3100-54040	REPAIR & MAINT EQUIPMENT	NAPA AUTO PARTS	BRAKE PARTS CLEANER	<u>128.52</u>	118681
Total For Check 118681				<u>595.33</u>	
Check 118682					
101-43-3100-54040	REPAIR & MAINT EQUIPMENT	O'REILLY AUTO PARTS	16.9OZSTOPLK	19.98	118682
631-49-9420-52100	OPERATING SUPPLIES	O'REILLY AUTO PARTS	19OZELCTCLNR	<u>11.69</u>	118682
Total For Check 118682				31.67	
Check 118683					
101-41-1940-53350	CONTRACT SERVICES	PLUNKETT'S VARMENT GUARD	GENERAL PEST CONTROL PROGRAM	<u>113.25</u>	118683
Total For Check 118683				113.25	
Check 118684					
101-00-0000-22400	BDE-0058	PMI HOMES INC	BD BOND REFUND - DEMOLITION ESCROW PB12400	<u>18,791.25</u>	118684
Total For Check 118684				18,791.25	
Check 118685					
101-41-1400-53070	PROFESSIONAL SERVICES	REDPATH AND COMPANY LLC	NOVEMBER 2025 SERVICES - FRACTIONAL FINANCE DIRECTOR	<u>5,510.00</u>	118685
Total For Check 118685				5,510.00	
Check 118686					
101-41-1320-53080	SEMINARS & TRAINING	SAFEASSURE CONSULTANTS INC	CONSULTING - SAFETY TRAINING	2,811.20	118686
101-43-3100-53080	SEMINARS & TRAINING	SAFEASSURE CONSULTANTS INC	CONSULTING - SAFETY TRAINING	2,248.96	118686
101-45-5200-53080	SEMINARS & TRAINING	SAFEASSURE CONSULTANTS INC	CONSULTING - SAFETY TRAINING	2,248.96	118686
205-43-3150-53080	SEMINARS & TRAINING	SAFEASSURE CONSULTANTS INC	CONSULTING - SAFETY TRAINING	2,248.96	118686
631-49-9420-53080	SEMINARS & TRAINING	SAFEASSURE CONSULTANTS INC	CONSULTING - SAFETY TRAINING	2,248.96	118686
632-49-9450-53080	SEMINARS & TRAINING	SAFEASSURE CONSULTANTS INC	CONSULTING - SAFETY TRAINING	<u>2,248.96</u>	118686
Total For Check 118686				14,056.00	
Check 118687					
101-41-1400-52210	REPAIR & MAINT SUPPLIES	SHRED-IT USA	SHREDDING SERVICES FOR NOVEMBER 2025	158.54	118687
101-42-2100-52210	REPAIR & MAINT SUPPLIES	SHRED-IT USA	SHREDDING SERVICES FOR NOVEMBER 2025	<u>158.54</u>	118687
Total For Check 118687				317.08	
Check 118688					
101-42-2100-52010	OFFICE SUPPLIES	SPS WORKS	MN NOTARY STAMP - M. SMITH	<u>77.94</u>	118688
Total For Check 118688				77.94	
Check 118689					
101-41-1940-52010	OFFICE SUPPLIES	STAPLES INC	HP 35A BLACK	78.75	118689
101-41-1940-52010	OFFICE SUPPLIES	STAPLES INC	BATTERY ALKALINE AA 144 PK & FEBREZE W/GAIN ORIG 2PK 8.8OZ	68.93	118689
101-41-1940-52010	OFFICE SUPPLIES	STAPLES INC	FBRZ AIR CRANCRUMB 2PK 8.8OZ	<u>5.99</u>	118689
Total For Check 118689				153.67	
Check 118690					
101-41-1910-53040-FLCODE-ENF	LEGAL SERVICES	STATE OF MN OFFICE OF ADMIN HEARING	REVIEW FILE/FILING, DRAFT DISMISSAL/DEFAULT	<u>216.00</u>	118690
Total For Check 118690				216.00	
Check 118691					

101-41-1320-53070	PROFESSIONAL SERVICES	TIMESAVER OFF SITE SECRETARIAL INC	11/10/2025 - CITY COUNCIL MEETING - VIEW WEBCAST - 1 HOURS - DRAFT MINUTES - 7.0 PAGES	176.25	118691
101-41-1320-53070	PROFESSIONAL SERVICES	TIMESAVER OFF SITE SECRETARIAL INC	11/17/2025 - COUNCIL WORKSHOP MEETING 1.75 HOURS	253.00	118691
101-41-1910-52100	OPERATING SUPPLIES	TIMESAVER OFF SITE SECRETARIAL INC	11/12/2025 - PLANNING COMMISSION MEETING 1.25 HOURS	212.50	118691
101-45-5120-53070-127555-001	PROFESSIONAL SERVICES	TIMESAVER OFF SITE SECRETARIAL INC	11/19/2025 - PARKS COMMISSION MEETING 1.25 HOURS	212.50	118691
		Total For Check 118691		<u>854.25</u>	
Check 118692					
101-41-1940-53350	CONTRACT SERVICES	TK ELEVATOR CORPORATION	GOLD - FULL MAINTENANCE - WITH PHONE MONITORING 12/01/25 - 02/28/26	657.18	118692
		Total For Check 118692		<u>657.18</u>	
Check 118693					
101-43-3100-54040	REPAIR & MAINT EQUIPMENT	TRI-STATE BOBCAT INC	SHOE SKID & FREIGHT	562.80	118693
		Total For Check 118693		<u>562.80</u>	
Check 118694					
101-43-3100-52100	OPERATING SUPPLIES	ULINE, INC	ULINE KRAFT SINGLE-FOLD TOWELS & ULINE PAPER PLATES - 10 1/4", HEAVYWEIGHT	400.58	118694
101-43-3100-52100	OPERATING SUPPLIES	ULINE, INC	STABILICERS® ICE TRACTION CLEATS - LARGE & STABILICERS® ICE TRACTION CLEATS - XL	610.57	118694
		Total For Check 118694		<u>1,011.15</u>	
Check 118695					
203-45-5200-53050-128559-001	PROFESSIONAL SERVICES	VALLEY VIEW TREE PLANTING LLC	PLANT 7, 8" ELM	5,250.00	118695
		Total For Check 118695		<u>5,250.00</u>	
Check 118696					
211-43-3100-54150	SIGNS & PAVEMENT MARKINGS	WASHINGTON COUNTY	LATEX STRIPING	6,932.60	118696
		Total For Check 118696		<u>6,932.60</u>	
Check 118697					
101-42-2100-52010	OFFICE SUPPLIES	WASHINGTON COUNTY	NOTARY COMMISSION APPLICATION - M. SMITH	20.00	118697
		Total For Check 118697		<u>20.00</u>	
Check 118698					
101-43-3180-53840	REFUSE DISPOSAL	WASHINGTON COUNTY PUBLIC HEALTH	VSQG HAZARDOUS WASTE COLLECTION PROGRAM - AEROSOLS	63.20	118698
		Total For Check 118698		<u>63.20</u>	
Check 118699					
631-49-9420-54020	REPAIR & MAINT - SUBS	WATER CONSERVATION SERVICES INC	OCTOBER 2025 ANNUAL WATER SYSTEM LEAK SURVEY - PARTIAL (EAST OF HIGHWAY 61)	2,800.00	118699
631-49-9420-54030	REPAIR & MAINT-IMPROVEMENTS	WATER CONSERVATION SERVICES INC	WATER LEAK LOCATE - 139 8TH AVE NE	381.90	118699
		Total For Check 118699		<u>3,181.90</u>	
Check 118700					
101-00-0000-22400	BEL-0149	WILLET REMODELING & CONSTRUCTION IN	BD BOND REFUND EROSION-LANDSCAPE ESCROW RELEASE PB11748	2,000.00	118700
		Total For Check 118700		<u>2,000.00</u>	
Check 118701					
101-45-5120-54380-SEVENT-001	PARKS PROGRAMS/ENTERTAINMENT	WOODROW MCBRIDE	ENTERTAINMENT PROMOTER 2026 - 1ST INSTALLMENT	578.34	118701
		Total For Check 118701		<u>578.34</u>	
Check 118702					
800-41-1910-53070-106081-108	PROFESSIONAL SERVICES	WYNCO PROPERTIES LLC	REFUND - WYNCO DENTAL CLINIC SITE IMPROVEMENTS	9,311.00	118702
		Total For Check 118702		<u>9,311.00</u>	
Check 118708					
631-00-0000-20800	OVERPAYMENT	ALEXANDER & ELIZABETH HATTSTROM	UB refund for account: 7116931	178.09	118708
		Total For Check 118708		<u>178.09</u>	

Check 118709 631-00-0000-20800	OVERPAYMENT	ALISSA MUDRICK Total For Check 118709	UB refund for account: 7110980	<u>87.79</u> 87.79	118709
Check 118710 101-42-2100-54040 101-42-2100-54040 101-42-2100-54040	REPAIR & MAINT EQUIPMENT REPAIR & MAINT EQUIPMENT REPAIR & MAINT EQUIPMENT	AMERICAN IMPORTS AMERICAN IMPORTS AMERICAN IMPORTS Total For Check 118710	SQUAD 2011 - MOUNT & BLANCE FOUR TIRES SQUAD 2605 - MOUNT & BALANCE FOUR TIRES SQUAD 2012 - ELECTRICAL SYSTEM CHECK & CHANGE OIL AND FILTER & SPARK PLUGS - REMOVE & REPLACE	722.99 625.99 <u>501.34</u> 1,850.32	118710 118710 118710
Check 118711 631-00-0000-20800	OVERPAYMENT	AMY PETERS Total For Check 118711	UB refund for account: 7112803	<u>121.73</u> 121.73	118711
Check 118712 631-00-0000-20800	OVERPAYMENT	ANDREA & TIMOTHY WINER Total For Check 118712	UB refund for account: 7114881	<u>70.10</u> 70.10	118712
Check 118713 631-00-0000-20800	OVERPAYMENT	ANDREW & SANDRA ROBERTS Total For Check 118713	UB refund for account: 7102186	<u>176.47</u> 176.47	118713
Check 118714 631-00-0000-20800	OVERPAYMENT	ASHLEY JOHNSON Total For Check 118714	UB refund for account: 7112680	<u>112.85</u> 112.85	118714
Check 118715 631-00-0000-20800	OVERPAYMENT	BARBARA SWING Total For Check 118715	UB refund for account: 7118450	<u>176.95</u> 176.95	118715
Check 118716 101-43-3100-52100	OPERATING SUPPLIES	BATTERIES PLUS BULBS Total For Check 118716	3V LITHIUM 1 PK DL 1/31VBPK, DURDL 13NB	<u>143.10</u> 143.10	118716
Check 118717 101-41-1500-52100 101-41-1500-52100	OPERATING SUPPLIES OPERATING SUPPLIES	BAYCOM INC BAYCOM INC Total For Check 118717	FZ-55 MK3, I5, TOUCH DISPLAY, 16GB, 512GB & 5G XPAK FOR TOUGHBOOK FZ-55 RETURN - 5G XPAK FOR TOUGHBOOK FZ-55	14,076.00 <u>(2,516.00)</u> 11,560.00	118717 118717
Check 118718 631-00-0000-20800	OVERPAYMENT	BITUMINOUS ROADWAYS Total For Check 118718	UB refund for account: 7117845	<u>375.60</u> 375.60	118718
Check 118719 101-41-1500-53090	COMPUTER SUPPORT	BLUUM OF MINNESOTA LLC Total For Check 118719	ONE YEAR OF REACH MEDIA DIGITAL SIGNAGE SOFTWARE LICENSE	<u>1,250.00</u> 1,250.00	118719
Check 118720 211-43-3135-53050-140937-000	ENGINEERING CHARGES	BOLTON & MENK INC Total For Check 118720	TOPOGRAPHIC SURVEY PW	<u>10,262.50</u> 10,262.50	118720
Check 118721 631-00-0000-20800	OVERPAYMENT	BRENT FLATEN Total For Check 118721	UB refund for account: 7102508	<u>68.95</u> 68.95	118721
Check 118722					

631-00-0000-20800	OVERPAYMENT	BRET & JULIE SMITH Total For Check 118722	UB refund for account: 7103202	<u>61.45</u> 61.45	118722
Check 118723 101-42-2200-52190	FOOD - FIRE DEPT	BRUCE'S FOODS INC Total For Check 118723	24 PK OF WATER QUANTITY - 8	<u>30.32</u> 30.32	118723
Check 118724 101-42-2100-52210	REPAIR & MAINT SUPPLIES	CAR WASH PARTNERS LLC Total For Check 118724	MISTER CAR WASH JULY 2025 SERVICES	<u>90.00</u> 90.00	118724
Check 118725 101-43-3180-52130 101-43-3180-52130	UNIFORMS & CLOTHING UNIFORMS & CLOTHING	CINTAS CORPORATION CINTAS CORPORATION Total For Check 118725	UNIFORM & CLOTHING - M.WELSH UNIFORM & CLOTHING - M.WELSH	86.45 <u>86.45</u> 172.90	118725 118725
Check 118726 101-41-1940-54010 101-46-6625-54010	REPAIR & MAINT-BUILDINGS REPAIR & MAINT-BUILDINGS	COMMERCIAL PLUMBING & HEATING INC COMMERCIAL PLUMBING & HEATING INC Total For Check 118726	CITY CENTER - SLOW LEAK ON TOILET IN MEN'S ROOM - FILL VALVE BAD ON THE TOILET SENIOR CENTER - SLOW LEAK ON TOILET IN MEN'S ROOM - REPLACED THE HANDLE AND FLAPPER	273.00 <u>308.00</u> 581.00	118726 118726
Check 118727 631-00-0000-20800	OVERPAYMENT	CORY CAPRA Total For Check 118727	UB refund for account: 7118438	<u>206.34</u> 206.34	118727
Check 118728 631-00-0000-20800	OVERPAYMENT	DAVID & LYNN SHEREE LESMEISTER Total For Check 118728	UB refund for account: 7103005	<u>145.31</u> 145.31	118728
Check 118729 631-00-0000-20800	OVERPAYMENT	DAVID & TINA WEEKS Total For Check 118729	UB refund for account: 7117837	<u>63.97</u> 63.97	118729
Check 118730 631-00-0000-20800	OVERPAYMENT	DAVID L WOOD Total For Check 118730	UB refund for account: 7100694	<u>83.85</u> 83.85	118730
Check 118731 101-41-1400-53070	PROFESSIONAL SERVICES	EHLERS Total For Check 118731	TIF STATUS UPDATE 2025	<u>993.75</u> 993.75	118731
Check 118732 631-00-0000-20800	OVERPAYMENT	EMPIRE PIPE SERVICE Total For Check 118732	UB refund for account: 7118279	<u>2,900.00</u> 2,900.00	118732
Check 118733 631-00-0000-20800	OVERPAYMENT	ERIC SORENSON Total For Check 118733	UB refund for account: 7114869	<u>156.19</u> 156.19	118733
Check 118734 631-00-0000-20800	OVERPAYMENT	ERIN GROSS Total For Check 118734	UB refund for account: 7115406	<u>449.95</u> 449.95	118734
Check 118735 631-00-0000-20800	OVERPAYMENT	ESTATE OF DORIS SULLIVAN Total For Check 118735	UB refund for account: 7104598	<u>93.38</u> 93.38	118735

Check 118736					
101-42-2200-52100	OPERATING SUPPLIES	FASTENAL COMPANY	1QTWAX&TARREMOVER	<u>108.14</u>	118736
		Total For Check 118736		108.14	
Check 118737					
101-42-2200-54040	REPAIR & MAINT EQUIPMENT	FIRE SAFETY USA INC	BRUSH #1 - SWAP SKIDS FROM OLD BRUSH #1 TO NEWER BRUSH#1 & REMOVE WATER TRANSFER PUMP	1,914.00	118737
101-42-2200-54040	REPAIR & MAINT EQUIPMENT	FIRE SAFETY USA INC	BURSH #2 - SWAP PUMP SKID OUT OF OLD BRUSH #2 TRUCK ALONG WITH WIRING, INSTALL SKID INTO NEW BRUSH #2	<u>1,635.00</u>	118737
		Total For Check 118737		3,549.00	
Check 118738					
101-42-2200-52100	OPERATING SUPPLIES	FOREST LAKE ACE HARDWARE	KEY PLAIN SINGLE CUT KEY	3.99	118738
101-43-3100-52100	OPERATING SUPPLIES	FOREST LAKE ACE HARDWARE	BATTERIES ALKALINE C 8PK & KING SIZE MARKER BLACK	27.17	118738
101-43-3100-52100	OPERATING SUPPLIES	FOREST LAKE ACE HARDWARE	FLOOR SQUEEGEE CURVD 24" & HANDLE TAPR 1-1/8X54" & FLOOR SQUEEGE RUBBR 24"W & STAPLE 3/4" NM WIRE 15P	78.56	118738
101-43-3180-52100	OPERATING SUPPLIES	FOREST LAKE ACE HARDWARE	FASTENERS	46.31	118738
631-49-9420-52100	OPERATING SUPPLIES	FOREST LAKE ACE HARDWARE	IMP STEP DRLBIT #1	<u>39.99</u>	118738
		Total For Check 118738		196.02	
Check 118739					
101-42-2100-52010	OFFICE SUPPLIES	FOREST LAKE PRINTING	PARKING WARNING SIGNS - FLPD - 4.25" X 11", 1/0, 10PT FLUORESCENT STRAWBERRY/ORANGE	<u>675.00</u>	118739
		Total For Check 118739		675.00	
Check 118740					
631-00-0000-20800	OVERPAYMENT	GARY & LUANA LITKE	UB refund for account: 7116052	<u>111.62</u>	118740
		Total For Check 118740		111.62	
Check 118741					
101-43-3100-54040	REPAIR & MAINT EQUIPMENT	GRAINGER INC	PINTLE HOOK,STEEL,8.4 IN	99.99	118741
631-49-9420-52100	OPERATING SUPPLIES	GRAINGER INC	SILENCER MUFFLER,1/4" FNPT,5/8" HEX	<u>15.12</u>	118741
		Total For Check 118741		115.11	
Check 118742					
101-46-6625-53350	CONTRACT SERVICES	GRANNY MAYS	MEAL SERVICES FOR DECEMBER	<u>216.00</u>	118742
		Total For Check 118742		216.00	
Check 118743					
631-00-0000-20800	OVERPAYMENT	GREGOR FALK	UB refund for account: 7116040	<u>44.93</u>	118743
		Total For Check 118743		44.93	
Check 118744					
401-42-2200-55500	CAP OUTLAY-VEHICLES	GUARDIAN FLEET SAFETY LLC	UNIT B1 - DECOMMISSION OF VEHICLE - STRIP ALL EMERGENCY EQUIPMENT FROM TRUCK & DECAL REMOVAL	975.00	118744
401-42-2200-55500	CAP OUTLAY-VEHICLES	GUARDIAN FLEET SAFETY LLC	UNIT B2 - DECOMMISSION OF VEHICLE - STRIP ALL EMERGENCY EQUIPMENT & REMOVE ALL DECALS	<u>975.00</u>	118744
		Total For Check 118744		1,950.00	
Check 118745					
631-49-9420-52160	CHEMICALS & TESTING	HAWKINS INC	150 LB CHLORINE CYLINDER BARCODE 131484 & 134038 & 119118 & 135868	40.00	118745
631-49-9420-52160	CHEMICALS & TESTING	HAWKINS INC	CHLORINE EPA 7870-2 & HYDROFLUOSILICIC ACID & LPC-4 & SODIUM HYDROXIDE 50% DIAPHRAGM	<u>6,560.45</u>	118745
		Total For Check 118745		6,600.45	
Check 118746					
101-43-3100-54040	REPAIR & MAINT EQUIPMENT	I - STATE TRUCK CENTER	TANK-SURGE,PLASTIC,M2, WST 470	<u>281.53</u>	118746
		Total For Check 118746		281.53	
Check 118747					
631-00-0000-20800	OVERPAYMENT	JAMES MATKO	UB refund for account: 7101097	<u>128.87</u>	118747
		Total For Check 118747		128.87	

Check 118748					
631-49-9420-53080	SEMINARS & TRAINING	JAMES NAPIERALA	APPLICATION FOR RECIPROCITY - WASTEWATER OPERATOR CERTIFICATION PROGAM	40.00	118748
631-49-9420-53080	SEMINARS & TRAINING	JAMES NAPIERALA	WATERWORKS OPERATOR EXAMINATION RESULTS	<u>23.00</u>	118748
		Total For Check 118748		<u>63.00</u>	
Check 118749					
631-00-0000-20800	OVERPAYMENT	JANELLE & JACOB MCGUIRE	UB refund for account: 7111508	<u>83.15</u>	118749
		Total For Check 118749		83.15	
Check 118750					
631-00-0000-20800	OVERPAYMENT	JERRY & SHIRLEY CARLSON	UB refund for account: 7111370	<u>272.94</u>	118750
		Total For Check 118750		272.94	
Check 118751					
631-00-0000-20800	OVERPAYMENT	JESSICA LACROIX	UB REFUND FOR ACCOUNT: 7108990	<u>141.18</u>	118751
		Total For Check 118751		141.18	
Check 118752					
631-00-0000-20800	OVERPAYMENT	JORDAN & LYNETTE SMITH	UB refund for account: 7116589	<u>105.43</u>	118752
		Total For Check 118752		105.43	
Check 118753					
631-00-0000-20800	OVERPAYMENT	KENNEDY TRANSMISSION	UB refund for account: 7108437	<u>463.97</u>	118753
		Total For Check 118753		463.97	
Check 118754					
631-00-0000-20800	OVERPAYMENT	KINSELLA PROPERTIES LLP	UB refund for account: 7117089	<u>107.18</u>	118754
		Total For Check 118754		107.18	
Check 118755					
101-41-1940-53350	CONTRACT SERVICES	KODIAK POWER SOLUTIONS	CITY CENTER - OIL & FILTER CHANGE & FUEL FILTER REPLACEMENT & MULTI-POINT INSPECTION & COOLING SYSTEM	625.00	118755
631-49-9420-54040	REPAIR & MAINT EQUIPMENT	KODIAK POWER SOLUTIONS	CITY CENTER - OIL & FILTER CHANGE & FUEL FILTER REPLACEMENT & MULTI-POINT INSPECTION & COOLING SYSTEM	2,590.00	118755
632-49-9450-54040	REPAIR & MAINT EQUIPMENT	KODIAK POWER SOLUTIONS	LS 7T - TRIP CHARGE & SERVICE	420.00	118755
632-49-9450-54040	REPAIR & MAINT EQUIPMENT	KODIAK POWER SOLUTIONS	LS 12 - HEATER HOTSTART 1500W 120V, 100-200, 10' CORD & 13A31-50 NATURAL GAS OUTDOOR VENT CAP 3/8" NP	435.40	118755
632-49-9450-54040	REPAIR & MAINT EQUIPMENT	KODIAK POWER SOLUTIONS	CITY CENTER - OIL & FILTER CHANGE & FUEL FILTER REPLACEMENT & MULTI-POINT INSPECTION & COOLING SYSTEM	<u>5,865.91</u>	118755
		Total For Check 118755		9,936.31	
Check 118756					
631-49-9420-54010	REPAIR & MAINT-BUILDINGS	KRAMER MECHANICAL	1850 8TH ST SE - REMOVED THE OLD BLOWER MOTOR, INSTALLED THE NEW MOTOR & RAN THE HEAT	<u>847.37</u>	118756
		Total For Check 118756		847.37	
Check 118757					
631-00-0000-20800	OVERPAYMENT	LANG BUILDERS	UB refund for account: 7117408	<u>283.73</u>	118757
		Total For Check 118757		283.73	
Check 118758					
101-45-5200-54250	RENTALS	LRS PORTABLES LLC	MULTIPLE RENTALS FOR PARKS	<u>330.36</u>	118758
		Total For Check 118758		330.36	
Check 118759					
631-00-0000-20800	OVERPAYMENT	MARK G SCHROM	UB refund for account: 7100934	<u>178.26</u>	118759
		Total For Check 118759		178.26	
Check 118760					
101-42-2200-52400	TOOLS & SMALL EQUIP	MENARDS	CLASSV - 5/8" HITCH PIN & CIV TO CIII ADAPTER	58.96	118760

101-43-3100-52100	OPERATING SUPPLIES	MENARDS	CREDIT ON ACCOUNT FOR \$47.98	(47.98)	118760
101-46-6625-54010	REPAIR & MAINT-BUILDINGS	MENARDS	PLATNM INT PAINT MAT UW & FORMIT 12PC PAINT KIT & DOOR STOP WALL W/BUMPER & WALLBITER MEDIUM WHITE	192.41	118760
101-46-6625-54010	REPAIR & MAINT-BUILDINGS	MENARDS	RETURN - PLATNM INT PAINT MAT UW & MN PAINTCARE RECOVERY FEE	(179.99)	118760
631-49-9420-52100	OPERATING SUPPLIES	MENARDS	GDSMN 2200L RCHG SPOTLT & 3/8 X 1-1/4 FEND WASH 5PC & 1-1/2 GALV SPLT RING HNGR & 3/8" HEX NUT 66PC	474.39	118760
631-49-9420-52100	OPERATING SUPPLIES	MENARDS	LXL/2 TXT BUSH PVC 80	12.87	118760
		Total For Check 118760		<u>510.66</u>	
Check 118761					
101-42-2100-54050	REPAIR & MAINT CONTRACTS	METRO SALES INC	RICOH/IM C3000 C4500 C6000 COLOR COPIES	1,399.08	118761
		Total For Check 118761		<u>1,399.08</u>	
Check 118762					
101-45-5200-54040	REPAIR & MAINT EQUIPMENT	MIDWEST MACHINERY CO	SEAL KIT & O-RING & LOCK WASHE & PLUG	109.81	118762
		Total For Check 118762		<u>109.81</u>	
Check 118763					
101-42-2100-53060	MEDICAL	MIDWEST RADIOLOGY	X-RAY EXAM CHEST 1 VIEW (CPT71045) - H. BELKA	26.00	118763
		Total For Check 118763		<u>26.00</u>	
Check 118764					
101-42-2200-53080	SEMINARS & TRAINING	MINNESOTA FIRE SERVICE CERTIFICATIO	FIRE OFFICER I CERTIFICATION EXAM TAKEN AT FOREST LAKE 11-13-25 - MULTIPLE FIREFIGHTERS	917.00	118764
		Total For Check 118764		<u>917.00</u>	
Check 118765					
631-49-9420-52160	CHEMICALS & TESTING	MINNESOTA VALLEY TESTING LABS	COLIFORM, MF - WATER	157.50	118765
		Total For Check 118765		<u>157.50</u>	
Check 118766					
631-00-0000-20800	OVERPAYMENT	NANCY ENSRUD	UB refund for account: 7100912	53.33	118766
		Total For Check 118766		<u>53.33</u>	
Check 118767					
101-42-2200-52210	REPAIR & MAINT SUPPLIES	NAPA AUTO PARTS	RV WATER SYSTEM ANTIFREEZE	20.52	118767
101-43-3100-54040	REPAIR & MAINT EQUIPMENT	NAPA AUTO PARTS	MOTOR TUNE-UP 16OZ	107.88	118767
101-43-3100-54040	REPAIR & MAINT EQUIPMENT	NAPA AUTO PARTS	TIRE VAL	25.83	118767
631-49-9420-52100	OPERATING SUPPLIES	NAPA AUTO PARTS	FHP POWERATED BELT	35.40	118767
		Total For Check 118767		<u>189.63</u>	
Check 118768					
631-00-0000-20800	OVERPAYMENT	NATHANIEL PETTIS	UB refund for account: 7113505	63.97	118768
		Total For Check 118768		<u>63.97</u>	
Check 118769					
101-46-6625-53350	CONTRACT SERVICES	NEWTRAX INC	FOREST LAKE AREA LOOP 11/05 & 11/12 & 11/19 & 11/26	1,858.99	118769
101-46-6625-53350	CONTRACT SERVICES	NEWTRAX INC	FOREST LAKE AREA LOOP 11/05 & 11/12 & 11/19 & 11/26	(88.00)	118769
		Total For Check 118769		<u>1,770.99</u>	
Check 118770					
101-45-5120-54380-HOMTWN-001	PARKS PROGRAMS/ENTERTAINMENT	NFL ELECTRIC INC	WOOD MATERIALS PROVIDED	340.00	118770
		Total For Check 118770		<u>340.00</u>	
Check 118771					
631-00-0000-20800	OVERPAYMENT	NOHEMI & CHRISTOPHER BROWN	UB refund for account: 7114485	73.64	118771
		Total For Check 118771		<u>73.64</u>	
Check 118772					

101-00-0000-22400	BDE-0053	NORDMANS MASTER LAWN CARE LLC	BD BOND REFUND - RELEASE OF DEMO ESCROW	<u>625.00</u>	118772
		Total For Check 118772		625.00	
Check 118773					
101-43-3100-54040	REPAIR & MAINT EQUIPMENT	O'REILLY AUTO PARTS	CAPSULE	113.03	118773
101-43-3100-54040	REPAIR & MAINT EQUIPMENT	O'REILLY AUTO PARTS	RETURN - CAPSULE	(11.05)	118773
101-43-3100-54040	REPAIR & MAINT EQUIPMENT	O'REILLY AUTO PARTS	S-RING PLIER	109.99	118773
101-43-3100-54040	REPAIR & MAINT EQUIPMENT	O'REILLY AUTO PARTS	WHL WEIGHT & OIL FILTER	48.46	118773
101-43-3100-54040	REPAIR & MAINT EQUIPMENT	O'REILLY AUTO PARTS	CALIPER	<u>29.99</u>	118773
		Total For Check 118773		290.42	
Check 118774					
631-00-0000-20800	OVERPAYMENT	OPENDOOR LABS INC.	UB refund for account: 7118220	<u>26.32</u>	118774
		Total For Check 118774		26.32	
Check 118775					
631-00-0000-20800	OVERPAYMENT	PAUL HUMPHREY	UB refund for account: 7111299	<u>197.28</u>	118775
		Total For Check 118775		197.28	
Check 118776					
631-00-0000-20800	OVERPAYMENT	PEG & JIM SIMPSON	UB refund for account: 7116128	<u>24.71</u>	118776
		Total For Check 118776		24.71	
Check 118777					
101-49-9200-36210	INTEREST EARNINGS	PMA ASSET MANAGEMENT LLC	ACCOUNT MANAGEMENT FEE 11/01/25 - 11/30/25	<u>1,991.31</u>	118777
		Total For Check 118777		1,991.31	
Check 118778					
205-43-3150-54370	MISCELLANEOUS	PRECISE MRM LLC	5MB FLAT DATA PLAN US WITH NAF C-US-5MB	<u>20.00</u>	118778
		Total For Check 118778		20.00	
Check 118779					
631-00-0000-20800	OVERPAYMENT	PSC	UB refund for account: 7118141	<u>2,900.00</u>	118779
		Total For Check 118779		2,900.00	
Check 118780					
101-45-5120-54380-HOMTWN-001	PARKS PROGRAMS/ENTERTAINMENT	RAPID PRESS	22" X 28" COROPLAST - HOMETOWN HOLIDAY - SPONSORSHIP BOARDS - MATTE LAM & 24" X 36" COROPLAST - HOMET	<u>450.00</u>	118780
		Total For Check 118780		450.00	
Check 118781					
631-00-0000-20800	OVERPAYMENT	RICHARD & RITA SPANIER	UB refund for account: 7101722	<u>411.43</u>	118781
		Total For Check 118781		411.43	
Check 118782					
631-00-0000-20800	OVERPAYMENT	RICHARD DUFRESNE	UB refund for account: 7118378	<u>169.75</u>	118782
		Total For Check 118782		169.75	
Check 118783					
631-00-0000-20800	OVERPAYMENT	RICHARD SALAVA	UB refund for account: 7105008	<u>41.47</u>	118783
		Total For Check 118783		41.47	
Check 118784					
631-00-0000-20800	OVERPAYMENT	ROBERT MAKI	UB refund for account: 7103219	<u>51.81</u>	118784
		Total For Check 118784		51.81	
Check 118785					

631-00-0000-20800	OVERPAYMENT	RONALD R REEDER Total For Check 118785	UB refund for account: 7100401	<u>105.24</u> 105.24	118785
Check 118786 631-00-0000-20800	OVERPAYMENT	RYAN KUTZ Total For Check 118786	UB refund for account: 7114813	<u>73.03</u> 73.03	118786
Check 118787 101-42-2200-54040	REPAIR & MAINT EQUIPMENT	SENSIT TECHNOLOGIES LLC Total For Check 118787	SENSIT G2 EX/CO/O2/TOX & BOTTOM HOUSING ASSEMBLY G2 & GASKET TONGUE G2 DRAWING# 320-00023 REV 6	<u>973.67</u> 973.67	118787
Check 118788 101-45-5120-53350	CONTRACT SERVICES	SESAC INC Total For Check 118788	SESAC MUSIC LICENSE 2026	<u>641.00</u> 641.00	118788
Check 118789 631-00-0000-20800	OVERPAYMENT	ST. CROIX RESTORATION Total For Check 118789	UB refund for account: 7117946	<u>2,503.20</u> 2,503.20	118789
Check 118790 101-41-1940-52100	OPERATING SUPPLIES	STAPLES INC	FLOOR CLNR PKT DSLVBLE 50PK	155.56	118790
101-41-1940-52100	OPERATING SUPPLIES	STAPLES INC	CLEANER,BATHRM,CLEANBLDG,SG	36.50	118790
101-41-1940-52100	OPERATING SUPPLIES	STAPLES INC	ELOVATE GLUCOSE PACKETS 2/BOX	35.67	118790
101-41-1940-52100	OPERATING SUPPLIES	STAPLES INC	PHYSICIANS CARE COLD & COUGH & PHYSIC. CARE ACETAMINOPHEN TAB	101.91	118790
101-41-1940-52100	OPERATING SUPPLIES	STAPLES INC	LINER 37X50 1.3MIL ACCUFT LLDP & NESTLE HOT COCOA PACKETS & PHYSICIANS CARE ASPIRIN TABLETS	228.36	118790
101-41-1940-52100	OPERATING SUPPLIES	STAPLES INC	SMALL POSTER STRIPS 104 PK & COMMAND MINI CLEAR HOOK	61.57	118790
101-41-1940-52100	OPERATING SUPPLIES	STAPLES INC	ADVANCED HYGIENE & CARE KIT & FEMININE HYGIENE KIT 6PCS & FIRST AID ONLY HYGIENE KIT	<u>83.73</u>	118790
		Total For Check 118790		703.30	
Check 118791 631-00-0000-20800	OVERPAYMENT	TAYLA GAEDE Total For Check 118791	UB refund for account: 7112722	<u>78.49</u> 78.49	118791
Check 118792 631-00-0000-20800	OVERPAYMENT	THOMAS / DARCI TANBERG Total For Check 118792	UB refund for account: 7110698	<u>115.72</u> 115.72	118792
Check 118793 101-41-1320-53070	PROFESSIONAL SERVICES	TIMESAVER OFF SITE SECRETARIAL INC	12/08/2025 CITY COUNCIL MEETING - VIEW WEBCAST - 2.5 HOURS - DRAFT MINUTES - 14.0 PAGES	352.50	118793
101-41-1320-53070	PROFESSIONAL SERVICES	TIMESAVER OFF SITE SECRETARIAL INC	11/24/2025 CITY COUNCIL MEETING - VIEW WEBCAST - 2 HOURS - DRAFT MINUTES - 11.0 PAGES	<u>282.25</u>	118793
		Total For Check 118793		634.75	
Check 118794 631-49-9420-52100	OPERATING SUPPLIES	TOTAL CONTROL SYSTEMS INC	WTP #4 - REPLACED OLD SONICWALL & PROGRAMMED, TESTED AND VERIFIED OPERATION	2,545.77	118794
631-49-9420-52100	OPERATING SUPPLIES	TOTAL CONTROL SYSTEMS INC	WTP #1/3 & WTP #2 & WTP #4 & TOWNSHIP SLS #16 CRADLEPOINT MONTHLY SERVICE	405.00	118794
632-49-9450-52100	OPERATING SUPPLIES	TOTAL CONTROL SYSTEMS INC	WTP #4 - REPLACED OLD SONICWALL & PROGRAMMED, TESTED AND VERIFIED OPERATION	2,251.28	118794
632-49-9450-52100	OPERATING SUPPLIES	TOTAL CONTROL SYSTEMS INC	WTP #1/3 & WTP #2 & WTP #4 & TOWNSHIP SLS #16 CRADLEPOINT MONTHLY SERVICE	<u>135.00</u>	118794
		Total For Check 118794		5,337.05	
Check 118795 101-42-2200-54040	REPAIR & MAINT EQUIPMENT	TOTAL VELOCITY ENGINEERING Total For Check 118795	MACHINE HINGE PIN FOR GREASE ZERK & ZERK, 1/16 NPT	<u>245.00</u> 245.00	118795
Check 118796 631-49-9420-52160	CHEMICALS & TESTING	USABLUEBOOK Total For Check 118796	(OR) HACH FLUORIDE REAGENT ARSENIC-FREE SPADNS 2; 25/PK	<u>440.20</u> 440.20	118796

Check 118797					
631-00-0000-20800	OVERPAYMENT	WENDY JACKSON	UB refund for account: 7114369	87.79	118797
		Total For Check 118797		87.79	
Check 118798					
101-42-2200-52120	MOTOR FUEL	WEX BANK	FIRE MORTOR FUEL - DECEMBER 2025	1,736.06	118798
		Total For Check 118798		1,736.06	
Check 118799					
101-42-2100-52120	MOTOR FUEL	WEX BANK	POLICE MOTOR FUEL - DECEMBER 2025	3,770.68	118799
		Total For Check 118799		3,770.68	
Check 118800					
101-43-3100-52120	MOTOR FUEL	WEX BANK	PUBLIC WORKS MOTOR FUEL - DECEMBER 2025	4,457.34	118800
101-43-3180-52120	MOTOR FUEL	WEX BANK	PUBLIC WORKS MOTOR FUEL - DECEMBER 2025	108.14	118800
101-45-5200-52120	MOTOR FUEL	WEX BANK	PUBLIC WORKS MOTOR FUEL - DECEMBER 2025	5,530.36	118800
205-43-3150-52120	MOTOR FUEL	WEX BANK	PUBLIC WORKS MOTOR FUEL - DECEMBER 2025	118.75	118800
631-49-9420-52120	MOTOR FUEL	WEX BANK	PUBLIC WORKS MOTOR FUEL - DECEMBER 2025	1,030.56	118800
632-49-9450-52120	MOTOR FUEL	WEX BANK	PUBLIC WORKS MOTOR FUEL - DECEMBER 2025	881.07	118800
		Total For Check 118800		12,126.22	
Check 118801					
101-42-2100-54040	REPAIR & MAINT EQUIPMENT	AMERICAN IMPORTS	SQUAD 2319 - LEFT FRONT TIRE LEAKING- FOUND SMALL PUNCTURE IN REPAIRABLE LOCATION & TIRE PATH REPAIR	30.19	118801
		Total For Check 118801		30.19	
Check 118802					
101-42-2100-54370	MISCELLANEOUS	BLUUM OF MINNESOTA LLC	WILL INSTALL A BRIGHTSIGN IN THE PD AREA CAPABLE OF SHOWING CCTV AND BRIGTSIGN MESSAGING	1,416.32	118802
101-42-2100-54370	MISCELLANEOUS	BLUUM OF MINNESOTA LLC	VIDEO SOURCE SOLUTION & AUTOMATIC SOFTWARE RENEWAL & MINNESOTA STATE CONTRACT DESGIN/ENGINEERING	2,908.00	118802
		Total For Check 118802		4,324.32	
Check 118803					
101-41-1910-53050-125526-001	ENGINEERING CHARGES	BOLTON & MENK INC	TEMPORARY PLANNING SERVICES	14,385.00	118803
101-43-3110-53050-106080-010	ENGINEERING CHARGES	BOLTON & MENK INC	GENERAL ROUTINE ENGINEERING	2,500.00	118803
203-45-5200-53050-128559-001	PROFESSIONAL SERVICES	BOLTON & MENK INC	BELTZ PARK IMPROVEMENTS	359.00	118803
203-45-5200-53050-138362-000	ENGINEERING CHARGES	BOLTON & MENK INC	VETERAN'S MEMORIAL LAKESIDE	3,830.80	118803
203-45-5200-53070-127555-001	PROFESSIONAL SERVICES	BOLTON & MENK INC	PARKS SYSTEM PLAN	352.50	118803
205-43-3150-53050	ENGINEERING CHARGES	BOLTON & MENK INC	STORMWATER SERVICES	577.00	118803
205-43-3150-53050-110000-001	ENGINEERING CHARGES	BOLTON & MENK INC	JD4 STORMWATER DESIGN	5,319.00	118803
205-43-3150-53050-124536-001	ENGINEERING CHARGES	BOLTON & MENK INC	MS4 ANNUALPROGRAM ASSISTANCE	687.50	118803
211-43-3135-53050-106207-010	ENGINEERING CHARGES	BOLTON & MENK INC	NON-ROUTINE ENGINEERING	1,884.50	118803
211-43-3135-53050-127722-001	ENGINEERING CHARGES	BOLTON & MENK INC	CSAH 32 PEDESTRIAN & STREET	447.50	118803
211-43-3135-53050-129714-001	ENGINEERING CHARGES	BOLTON & MENK INC	TH 97 IMPROVEMENT PROJECT	6,633.50	118803
211-43-3135-53050-131361-001	ENGINEERING CHARGES	BOLTON & MENK INC	EUREKA AVENUE IMPROVEMENTS	19,192.60	118803
211-43-3135-53050-134732-001	ENGINEERING CHARGES	BOLTON & MENK INC	NORTH SHORE TRAIL	25,222.00	118803
211-43-3135-53050-140937-000	ENGINEERING CHARGES	BOLTON & MENK INC	PUBLIC WORKS FACILITY	460.00	118803
211-43-3135-54080-136586-001	MAINT ASPHALT MILL & OVERLAY	BOLTON & MENK INC	2025 LOCAL ST IMPROVEMENT	3,963.00	118803
211-43-3135-54080-141275-000	MAINT ASPHALT MILL & OVERLAY	BOLTON & MENK INC	2026 LOCAL ST IMPROVEMENT	184.00	118803
212-46-1920-53070	PROFESSIONAL SERVICES	BOLTON & MENK INC	SOUTHWEST STUDY AREA	1,789.50	118803
631-00-0000-15000-120880-001	CONSTRUCTION IN PROGRESS	BOLTON & MENK INC	WTP 4 CONSTRUCTION	70.00	118803
631-00-0000-15000-136449-001	CONSTRUCTION IN PROGRESS-S H2O TOWE	BOLTON & MENK INC	2025 SOUTH WATER TOWER REHAB	2,752.00	118803
631-49-9420-53050	ENGINEERING CHARGES	BOLTON & MENK INC	NON-ROUTINE ENGINEERING	810.00	118803
800-41-1910-53050-106081-092	ENGINEERING CHARGES	BOLTON & MENK INC	MULTIPLE ITEMS - SITE DEVELOPMENT	626.50	118803
800-41-1910-53050-106081-104	ENGINEERING CHARGES	BOLTON & MENK INC	MULTIPLE ITEMS - SITE DEVELOPMENT	552.50	118803
800-41-1910-53050-106081-108	ENGINEERING CHARGES	BOLTON & MENK INC	MULTIPLE ITEMS - SITE DEVELOPMENT	1,084.00	118803
800-41-1910-53050-106081-111	ENGINEERING CHARGES	BOLTON & MENK INC	MULTIPLE ITEMS - SITE DEVELOPMENT	92.00	118803
800-41-1910-53050-106081-114	ENGINEERING CHARGES	BOLTON & MENK INC	MULTIPLE ITEMS - SITE DEVELOPMENT	8,690.00	118803

800-41-1910-53050-106081-116	ENGINEERING CHARGES	BOLTON & MENK INC	MULTIPLE ITEMS - SITE DEVELOPMENT	894.50	118803
800-41-1910-53050-106081-505	ENGINEERING CHARGES	BOLTON & MENK INC	AMBERLY WOODS FKA SURINE	1,251.00	118803
800-41-1910-53050-111058-001	ENGINEERING CHARGES	BOLTON & MENK INC	PHASE 2 CHESTNUT CREEK	716.00	118803
800-41-1910-53050-123268-001	ENGINEERING CHARGES	BOLTON & MENK INC	FOREST HILLS FARM PHASE II	179.00	118803
800-41-1910-53050-123780-001	ENGINEERING CHARGES	BOLTON & MENK INC	HIDDEN CREEK	12,843.00	118803
800-41-1910-53050-125722-001	ENGINEERING CHARGES	BOLTON & MENK INC	SHADOW CREEK STABLES ESTATES	2,108.50	118803
800-41-1910-53050-139222-000	ENGINEERING CHARGES	BOLTON & MENK INC	FOREST VIEW ESTATES FKA BITT	1,365.00	118803
800-41-1910-53050-141276-001	ENGINEERING CHARGES	BOLTON & MENK INC	TEMPORARY PLANNING SERVICES	714.00	118803
800-41-1910-53050-141277-001	ENGINEERING CHARGES	BOLTON & MENK INC	FOREST HILLS GOLF CLUB INC - PROPERTY REVIEWS	910.00	118803
800-41-1910-53050-141278-001	ENGINEERING CHARGES	BOLTON & MENK INC	SHELANDER - WETLAND DELINEATION - PROPERTY REVIEWS	637.00	118803
800-41-1910-53050-141279-001	ENGINEERING CHARGES	BOLTON & MENK INC	MULTIPLE ITEMS - SITE DEVELOPMENT	2,215.00	118803
800-41-1910-53070-141276-001	PROFESSIONAL SERVICES	BOLTON & MENK INC	HOSANNA LUTHERAN CHURCH AMENDMENT - PROPERTY REVIEWS	1,036.00	118803
		Total For Check 118803		<u>127,333.40</u>	
Check 118804					
631-49-9420-52160	CHEMICALS & TESTING	CARGILL INC	KD CRSE SO BULK NSF 60 - 47,620.00 LB	6,494.42	118804
		Total For Check 118804		<u>6,494.42</u>	
Check 118805					
101-43-3100-52100	OPERATING SUPPLIES	CINTAS CORPORATION	REFILLS FOR FIRST AID KITS	61.47	118805
101-43-3180-52130	UNIFORMS & CLOTHING	CINTAS CORPORATION	UNIFORM & CLOTHING - M.WELSH	86.45	118805
		Total For Check 118805		<u>147.92</u>	
Check 118806					
101-46-6625-53350	CONTRACT SERVICES	DAVID D. DREWS	CLEANING SVCES FOR DECEMBER 2025 FL SENIOR CENTER	850.00	118806
		Total For Check 118806		<u>850.00</u>	
Check 118807					
632-49-9450-37150	PW - INSPECTION OF SEWER - RESIDENTIAL	DEAN'S HOME SERVICES	BD PAYMENT REFUND - RETURN OF PAYMENT	40.00	118807
		Total For Check 118807		<u>40.00</u>	
Check 118808					
101-41-1400-53520	PUBLISHING & ADS	ECM PUBLISHERS INC	ORD NO 764 - 2026 FEE SCHEDULE	24.00	118808
101-42-2400-52010	OFFICE SUPPLIES	ECM PUBLISHERS INC	BUSINESS CARDS - J. WAGNER	53.00	118808
		Total For Check 118808		<u>77.00</u>	
Check 118809					
101-41-1400-53070	PROFESSIONAL SERVICES	EHLERS	2025 FINANCIAL MANAGEMENT PLAN UPDATE	295.00	118809
323-47-7010-56010	BOND PRINCIPAL	EHLERS	\$2,205,000.00 GENERAL OBLIGATION EQUIPMENT CERTIFICATES, SERIES 2024A	135,000.00	118809
323-47-7010-56110	INTEREST EXPENSE	EHLERS	\$2,205,000.00 GENERAL OBLIGATION EQUIPMENT CERTIFICATES, SERIES 2024A	51,200.00	118809
325-47-7010-56010	BOND PRINCIPAL	EHLERS	\$8,895,000.00 GENERAL OBLIGATION TAX ABATEMENT BONDS, SERIES 2014A	445,000.00	118809
325-47-7010-56110	INTEREST EXPENSE	EHLERS	\$8,895,000.00 GENERAL OBLIGATION TAX ABATEMENT BONDS, SERIES 2014A	76,906.25	118809
326-47-7010-56110	BOND INTEREST	EHLERS	\$30,710,000.00 GENERAL OBLIGATION BONDS, SERIES 2019A	475.00	118809
328-47-7010-56010	BOND PRINCIPAL	EHLERS	\$30,710,000.00 GENERAL OBLIGATION BONDS, SERIES 2019A	1,860,000.00	118809
328-47-7010-56110	INTEREST EXPENSE	EHLERS	\$30,710,000.00 GENERAL OBLIGATION BONDS, SERIES 2019A	452,075.00	118809
328-47-7010-56110	INTEREST EXPENSE	EHLERS	\$4,145,000.00 GENERAL OBLIGATION STREET RECONSTRUCTION PLAN BONDS, SERIES 2025A	122,752.78	118809
328-47-7010-56200	PAYING AGENT FEES	EHLERS	\$4,145,000.00 GENERAL OBLIGATION STREET RECONSTRUCTION PLAN BONDS, SERIES 2025A	475.00	118809
632-47-7010-56010	BOND PRINCIPAL	EHLERS	\$4,315,000.00 GENERAL OBLIGATION WASTEWATER REVENUE BONDS, SERIES 2016A	290,000.00	118809
632-47-7010-56110	INTEREST EXPENSE	EHLERS	\$4,315,000.00 GENERAL OBLIGATION WASTEWATER REVENUE BONDS, SERIES 2016A	26,560.00	118809
		Total For Check 118809		<u>3,460,739.03</u>	
Check 118810					
101-46-6625-53350	CONTRACT SERVICES	ELECTRO WATCHMAN INC	FIRE ALARM SYSTEM MONITORING SENIOR CENTER 001/01/25 - 03/31/25	148.35	118810
		Total For Check 118810		<u>148.35</u>	
Check 118811					
101-42-2200-54040	REPAIR & MAINT EQUIPMENT	FIRE SAFETY USA INC	ENGINE 2 - CUSTOMER STATED AIR LEAK AT KUSSMAUL AUTO PUMP & LOCATED AIR LEAK AND TIGHTEN LOOSE DIAPHR	243.75	118811

		Total For Check 118811		<u>243.75</u>	
Check 118812					
631-49-9420-52100	OPERATING SUPPLIES	FOREST LAKE ACE HARDWARE	KEY PLAIN SINGLE CUT KEY	<u>23.94</u>	118812
		Total For Check 118812		<u>23.94</u>	
Check 118813					
101-43-3100-54020	REPAIR & MAINT - SUBS	FOREST LAKE CONTRACTING INC	WEST FENCE REPAIR BROADWAY BRIDGE @ 35 - FOR FENCE WORK TO DATE & FENCE REMOVAL FOUNDATION	5,516.50	118813
101-43-3100-54020	REPAIR & MAINT - SUBS	FOREST LAKE CONTRACTING INC	EAST FENCE REPAIR BROADWAY BRIDGE @ 35 - FOR FENCE WORK TO DATE & FENCE REMOVAL FOUNDATION REMOVE	9,870.52	118813
211-43-3135-53070-131361-001	PROFESSIONAL SERVICES	FOREST LAKE CONTRACTING INC	CONTRACTOR'S PAY REQUEST #1 - EUREKA AVENUE IMPROVEMENTS PROJECT	<u>52,922.36</u>	118813
		Total For Check 118813		<u>68,309.38</u>	
Check 118814					
101-42-2100-54040	REPAIR & MAINT EQUIPMENT	FOREST LAKE FORD	SERVICES ON FORD EXPLORER - PERFORM ENGINE OIL AND FILTER CHANGE & MULTI POINT VEHICLE SAFETY INSPECT	<u>73.85</u>	118814
		Total For Check 118814		<u>73.85</u>	
Check 118815					
101-42-2100-53040	LEGAL SERVICES	HEBERT AND WELCH PA	LEGAL SERVICES FOR DECEMBER 2025	<u>12,551.00</u>	118815
		Total For Check 118815		<u>12,551.00</u>	
Check 118816					
101-43-3100-54040	REPAIR & MAINT EQUIPMENT	I - STATE TRUCK CENTER	SENSOR,NITROGEN OXIDE & (4326872D) SENSOR,NITROGEN OXI & PARTS- DELIVERY CHARGE	872.37	118816
101-43-3100-54040	REPAIR & MAINT EQUIPMENT	I - STATE TRUCK CENTER	KIT,TURBOCHARGER ACTUATOR & KIT,TURBOCHARGER AC	<u>1,901.17</u>	118816
		Total For Check 118816		<u>2,773.54</u>	
Check 118817					
101-46-6625-54330	DUES & SUBSCRIPTIONS	IEDITWEB INC	SENIOR CENTER HOSTING WEBSITE 01/26/26 - 02/25/26	<u>39.95</u>	118817
		Total For Check 118817		<u>39.95</u>	
Check 118818					
101-41-1400-53700	MILEAGE REIMB	KATIE SMITH	4TH QTR 2025 - MILEAGE REIMBURSEMENT FOR TRIPS TO THE BANK	<u>9.80</u>	118818
		Total For Check 118818		<u>9.80</u>	
Check 118819					
101-42-2100-52100	OPERATING SUPPLIES	KIESLER POLICE SUPPLY	GLOCK 17MOS GENS 9MM PISTOL BLACK, FRONT SERRATIONS, FIXED SIGHTS & GLOCK 19MOS GENS 9MM PISTOL BLACK	<u>255.72</u>	118819
		Total For Check 118819		<u>255.72</u>	
Check 118820					
632-49-9450-52100	OPERATING SUPPLIES	MACQUEEN EQUIPMENT LLC	6' MLEXFML POLE & GREASE CHOPPER	<u>2,074.47</u>	118820
		Total For Check 118820		<u>2,074.47</u>	
Check 118821					
212-46-1920-54370	MISCELLANEOUS	MCCPD	MCCPD - 8241 NORTH SHORE TRAIL NORTH	<u>9,237.50</u>	118821
		Total For Check 118821		<u>9,237.50</u>	
Check 118822					
101-43-3100-52100	OPERATING SUPPLIES	MENARDS	MF-SKT SET 3/8DR 21PC SAE & MF-SKT SET 3/8DR 21PC MM & 16PC COMBO FLD HEXKEY SET & 6 PC FOLD UP	354.64	118822
631-49-9420-52100	OPERATING SUPPLIES	MENARDS	12GAL 5.5HP POLY VAC & DURACELL ALK. 9V-4 PK & 50' 12/3 NEON GRN CORD	<u>253.43</u>	118822
		Total For Check 118822		<u>608.07</u>	
Check 118823					
101-41-1500-53090	COMPUTER SUPPORT	METRO-INET	TICKET 207443 - MICROSOFT OFFICE 365 LICENSE - H. BELKA	<u>158.00</u>	118823
		Total For Check 118823		<u>158.00</u>	
Check 118824					
101-42-2200-53090	COMPUTER SUPPORT	MIDCONTINENT COMMUNICATIONS	COLUMBUS FIRE SUB STATION JANUARY 2026	126.88	118824

		Total For Check 118824		<u>126.88</u>	
Check 118825					
101-43-3100-53060	MEDICAL	MIDWEST COMPLIANCE INC	DRUG TESTS OCTOBER - C. LARSON & M. CAPRA & J. FASBENDER	150.00	118825
101-43-3100-53060	MEDICAL	MIDWEST COMPLIANCE INC	DRUG TESTS NOVEMBER - M. WELSH	50.00	118825
		Total For Check 118825		<u>200.00</u>	
Check 118826					
212-46-1920-54370	MISCELLANEOUS	MILLER AND STEVENS	MILLER & STEVENS - 92 LAKE STREET SOUTH	5,725.00	118826
		Total For Check 118826		<u>5,725.00</u>	
Check 118827					
631-49-9420-52160	CHEMICALS & TESTING	MINNESOTA VALLEY TESTING LABS	COLIFORM, MF - WATER	160.00	118827
		Total For Check 118827		<u>160.00</u>	
Check 118828					
101-43-3100-52100	OPERATING SUPPLIES	NAPA AUTO PARTS	16IN TRICO CHILL BLDE & 16IN TRICO ICE BLADE	68.16	118828
		Total For Check 118828		<u>68.16</u>	
Check 118829					
101-41-1500-53090	COMPUTER SUPPORT	NEOGOVS	GOVERNMENTJOBS.COM SETUP & SUBSCRIPTION & INSIGHT SETUP & SUBSCRIPTION & ONBOARD SETUP & SUBSCRIPTION	12,633.60	118829
		Total For Check 118829		<u>12,633.60</u>	
Check 118830					
101-43-3100-54020	REPAIR & MAINT - SUBS	OLSON'S SEWER SERVICE INC	SNOWPLOWING AT LAKESIDE PARK ON 11/26/25 & 11/30/25 & 12/10/25 WITH T66 OR T595 BOBCAT & CAT924H	4,717.91	118830
		Total For Check 118830		<u>4,717.91</u>	
Check 118831					
211-43-3135-53070-131361-001	PROFESSIONAL SERVICES	PATCHIN MESSNER VALUATION COUNSELOR	EUREKA AVENUE RECONSTRUCTION PROJECT - CLEAR LAKE PUBLIC ACCESS PROPERTY - OWNED BY: MINNESOTA DNR	1,500.00	118831
		Total For Check 118831		<u>1,500.00</u>	
Check 118832					
101-41-1910-53070-FLCODE-ENF	PROFESSIONAL SERVICES	RJ'S PROPERTY MAINTENANCE INC	SNOW REMOVAL AT MULTIPLE LOCATIONS	3,850.00	118832
101-41-1910-53070-FLCODE-ENF	PROFESSIONAL SERVICES	RJ'S PROPERTY MAINTENANCE INC	SNOW REMOVAL AT MULTIPLE LOCATIONS	1,400.00	118832
101-41-1910-53070-FLCODE-ENF	PROFESSIONAL SERVICES	RJ'S PROPERTY MAINTENANCE INC	SNOW REMOVAL AT MULTIPLE LOCATIONS	2,350.00	118832
101-41-1910-53070-FLCODE-ENF	PROFESSIONAL SERVICES	RJ'S PROPERTY MAINTENANCE INC	SNOW REMOVAL AT MULTIPLE LOCATIONS	2,250.00	118832
101-41-1910-53070-FLCODE-ENF	PROFESSIONAL SERVICES	RJ'S PROPERTY MAINTENANCE INC	SNOW REMOVAL AT MULTIPLE LOCATIONS	3,600.00	118832
		Total For Check 118832		<u>13,450.00</u>	
Check 118833					
101-41-1400-52210	REPAIR & MAINT SUPPLIES	SHRED-IT USA	SHREDDING SERVICES FOR DECEMBER 2025	167.13	118833
101-42-2100-52210	REPAIR & MAINT SUPPLIES	SHRED-IT USA	SHREDDING SERVICES FOR DECEMBER 2025	168.13	118833
		Total For Check 118833		<u>335.26</u>	
Check 118834					
101-45-5200-52100	OPERATING SUPPLIES	ST CROIX RECREATION FUN PLAYGROUNDS	3/16" GALVANIZED CHAIN	590.00	118834
		Total For Check 118834		<u>590.00</u>	
Check 118835					
401-42-2100-55500	CAP OUTLAY-VEHICLES	TENVOORDE FORD INC	PURCHASE OF NEW SQUAD 2613 - 2026 POLICE INTERCEPTOR UTILITY AWD K8A S	52,164.44	118835
401-42-2100-55500	CAP OUTLAY-VEHICLES	TENVOORDE FORD INC	PURCHASE OF NEW SQUAD 2612 - 2026 POLICE INTERCEPTOR UTILITY AWD K8A S	52,164.44	118835
		Total For Check 118835		<u>104,328.88</u>	
Check 118836					
101-45-5120-54380-HOMTWN-001	PARKS PROGRAMS/ENTERTAINMENT	THE MUSIC CONNECTION INC	CHRISTMAS 2025 - SHORT TERM RENTAL-BLUETOOTH GAZEBO & MONITOR FOR GAZEBO & WIRELESS MIC TREE	990.00	118836
		Total For Check 118836		<u>990.00</u>	

Check 118837					
101-41-1910-52100	OPERATING SUPPLIES	TIMESAVER OFF SITE SECRETARIAL INC	12/10/2025 - PLANNING COMMISSION MEETING - VIEW WEBCAST - 1.5 HOURS - DRAFT MINUTES - 9.0 PAGES	229.25	118837
101-45-5120-53070	PROFESSIONAL SERVICES	TIMESAVER OFF SITE SECRETARIAL INC	12/17/2025 - PARKS COMMISSION MEETING 1.5 HOURS	212.50	118837
212-46-1920-52100	OPERATING SUPPLIES	TIMESAVER OFF SITE SECRETARIAL INC	12/01/2025 EDA MEETING - VIEW WEBCAST - 1.5 HOURS - DRAFT MINUTES - 9.0 PAGES	229.25	118837
Total For Check 118837				<u>671.00</u>	
Check 118838					
101-43-3100-52100	OPERATING SUPPLIES	WINNICK SUPPLY INC	MILWAUKEE 80PC SHOCKWAVE DRIVER BIT SET & 29 PIECE DRILL BIT ULTRA-DEX MILWAUKEE 18PC SHOCKWAVE	361.24	118838
101-43-3180-52100	OPERATING SUPPLIES	WINNICK SUPPLY INC	29 PIECE DRILL BIT ULTRA-DEX & MILWAUKEE 80PC SHOCKWAVE DRIVER BIT SET	301.27	118838
631-49-9420-52100	OPERATING SUPPLIES	WINNICK SUPPLY INC	1 1/2" UNION PVC SCHEDULE 80 & 1 1/2" MALE ADAPTER PVC SCHEDULE 80	56.01	118838
Total For Check 118838				<u>718.52</u>	
Check 2528					
101-41-1320-53210	651-262-9618 J. CHAIKA	VERIZON WIRELESS	VERIZON WIRELESS SEP 11 - OCT 10 2025	38.41	2528
101-41-1320-53210	651-418-0827 M. STATZ	VERIZON WIRELESS	VERIZON WIRELESS SEP 11 - OCT 10 2025	38.41	2528
101-41-1910-53210	651-418-3960 A. WITTMAN	VERIZON WIRELESS	VERIZON WIRELESS SEP 11 - OCT 10 2025	38.41	2528
101-41-1940-53210	651-368-2551 D. HAIDER	VERIZON WIRELESS	VERIZON WIRELESS SEP 11 - OCT 10 2025	48.81	2528
101-41-1940-53210	651-755-1235 D. FLOHR	VERIZON WIRELESS	VERIZON WIRELESS SEP 11 - OCT 10 2025	38.41	2528
101-42-2100-53210	763-301-4526 L. HANEGRAAF	VERIZON WIRELESS	VERIZON WIRELESS SEP 11 - OCT 10 2025	40.01	2528
101-42-2100-53210	763-301-4556 L. HANEGRAAF	VERIZON WIRELESS	VERIZON WIRELESS SEP 11 - OCT 10 2025	40.01	2528
101-42-2100-53210	763-341-0274 FLPD FL2002	VERIZON WIRELESS	VERIZON WIRELESS SEP 11 - OCT 10 2025	40.01	2528
101-42-2100-53210	763-401-2179 T. SCHIMMELMAN	VERIZON WIRELESS	VERIZON WIRELESS SEP 11 - OCT 10 2025	38.41	2528
101-42-2100-53210	952-324-6046 FLPD FL2013	VERIZON WIRELESS	VERIZON WIRELESS SEP 11 - OCT 10 2025	40.01	2528
101-42-2100-53210	952-324-6052 FLPD FL2011	VERIZON WIRELESS	VERIZON WIRELESS SEP 11 - OCT 10 2025	40.01	2528
101-42-2100-53210	952-324-6141 FLPD FL2005	VERIZON WIRELESS	VERIZON WIRELESS SEP 11 - OCT 10 2025	40.01	2528
101-42-2100-53210	952-324-6152 FLPD FL2208	VERIZON WIRELESS	VERIZON WIRELESS SEP 11 - OCT 10 2025	40.01	2528
101-42-2100-53210	612-581-7139 SQUAD 2104	VERIZON WIRELESS	VERIZON WIRELESS SEP 11 - OCT 10 2025	40.01	2528
101-42-2100-53210	612-581-7480 SQUAD 2319	VERIZON WIRELESS	VERIZON WIRELESS SEP 11 - OCT 10 2025	40.01	2528
101-42-2100-53210	612-581-7507 SQUAD 2115	VERIZON WIRELESS	VERIZON WIRELESS SEP 11 - OCT 10 2025	40.01	2528
101-42-2100-53210	612-581-7573 SQUAD 2013	VERIZON WIRELESS	VERIZON WIRELESS SEP 11 - OCT 10 2025	40.01	2528
101-42-2100-53210	612-581-8423 SQUAD 2107	VERIZON WIRELESS	VERIZON WIRELESS SEP 11 - OCT 10 2025	40.01	2528
101-42-2100-53210	612-581-6901 SQUAD 2012	VERIZON WIRELESS	VERIZON WIRELESS SEP 11 - OCT 10 2025	40.01	2528
101-42-2100-53210	651-396-2613 SQUAD 2208	VERIZON WIRELESS	VERIZON WIRELESS SEP 11 - OCT 10 2025	40.01	2528
101-42-2100-53210	651-396-3298 SQUAD 1809	VERIZON WIRELESS	VERIZON WIRELESS SEP 11 - OCT 10 2025	40.01	2528
101-42-2100-53210	651-396-4966 SQUAD 2416	VERIZON WIRELESS	VERIZON WIRELESS SEP 11 - OCT 10 2025	40.01	2528
101-42-2100-53210	651-470-3439 401 PD JETPACK	VERIZON WIRELESS	VERIZON WIRELESS SEP 11 - OCT 10 2025	40.01	2528
101-42-2100-53210	651-478-0136 SEWER/WATER DEPT IPAD	VERIZON WIRELESS	VERIZON WIRELESS SEP 11 - OCT 10 2025	20.02	2528
101-42-2100-53210	651-478-0669 C. JOHNSON	VERIZON WIRELESS	VERIZON WIRELESS SEP 11 - OCT 10 2025	38.41	2528
101-42-2100-53210	651-509-4536 SQUAD 2005	VERIZON WIRELESS	VERIZON WIRELESS SEP 11 - OCT 10 2025	40.01	2528
101-42-2100-53210	651-724-2090 A. YATES	VERIZON WIRELESS	VERIZON WIRELESS SEP 11 - OCT 10 2025	38.41	2528
101-42-2100-53210	651-724-5578 T. COULTER	VERIZON WIRELESS	VERIZON WIRELESS SEP 11 - OCT 10 2025	38.41	2528
101-42-2100-53210	651-724-8880 J. BROWN	VERIZON WIRELESS	VERIZON WIRELESS SEP 11 - OCT 10 2025	38.41	2528
101-42-2100-53210	651-421-6901 L. HANEGRAAF	VERIZON WIRELESS	VERIZON WIRELESS SEP 11 - OCT 10 2025	40.01	2528
101-42-2100-53210	651-755-1203 B. DEGROOT	VERIZON WIRELESS	VERIZON WIRELESS SEP 11 - OCT 10 2025	38.41	2528
101-42-2100-53210	651-325-6426 R. PETERSON	VERIZON WIRELESS	VERIZON WIRELESS SEP 11 - OCT 10 2025	38.41	2528
101-42-2100-53210	651-325-6598 T. COKCBURN	VERIZON WIRELESS	VERIZON WIRELESS SEP 11 - OCT 10 2025	38.41	2528
101-42-2100-53210	651-325-6597 M. KARNES	VERIZON WIRELESS	VERIZON WIRELESS SEP 11 - OCT 10 2025	38.41	2528
101-42-2100-53210	651-325-6595 T. MEYER	VERIZON WIRELESS	VERIZON WIRELESS SEP 11 - OCT 10 2025	38.41	2528
101-42-2100-53210	651-325-6594 R. WARKE	VERIZON WIRELESS	VERIZON WIRELESS SEP 11 - OCT 10 2025	38.41	2528
101-42-2100-53210	651-325-6593 J. GLADER	VERIZON WIRELESS	VERIZON WIRELESS SEP 11 - OCT 10 2025	38.41	2528
101-42-2100-53210	651-325-6591 S. LAFFERTY	VERIZON WIRELESS	VERIZON WIRELESS SEP 11 - OCT 10 2025	38.41	2528
101-42-2100-53210	651-325-6590 J. AYERS	VERIZON WIRELESS	VERIZON WIRELESS SEP 11 - OCT 10 2025	38.41	2528
101-42-2100-53210	651-325-6589 N. KENT	VERIZON WIRELESS	VERIZON WIRELESS SEP 11 - OCT 10 2025	38.41	2528
101-42-2100-53210	651-325-6588 M. RICHERT	VERIZON WIRELESS	VERIZON WIRELESS SEP 11 - OCT 10 2025	38.41	2528
101-42-2100-53210	952-324-6229 FLPD FL1809	VERIZON WIRELESS	VERIZON WIRELESS SEP 11 - OCT 10 2025	40.01	2528
101-42-2100-53210	651-248-5838 N. CARLSON	VERIZON WIRELESS	VERIZON WIRELESS SEP 11 - OCT 10 2025	38.41	2528
101-42-2100-53210	612-494-2962 FLPD 2319	VERIZON WIRELESS	VERIZON WIRELESS SEP 11 - OCT 10 2025	40.01	2528

101-42-2100-53210	612-463-9664 O. RUDE	VERIZON WIRELESS	VERIZON WIRELESS SEP 11 - OCT 10 2025	38.41	2528
101-42-2100-53210	612-419-1365 J. GRIFFIN	VERIZON WIRELESS	VERIZON WIRELESS SEP 11 - OCT 10 2025	38.41	2528
101-42-2100-53210	612-391-5880 L. HANEGRAFF	VERIZON WIRELESS	VERIZON WIRELESS SEP 11 - OCT 10 2025	38.41	2528
101-42-2100-53210	651-318-7476 FLPD FL2012	VERIZON WIRELESS	VERIZON WIRELESS SEP 11 - OCT 10 2025	40.01	2528
101-42-2100-53210	612-231-7428 N. OLSTAD	VERIZON WIRELESS	VERIZON WIRELESS SEP 11 - OCT 10 2025	38.41	2528
101-42-2100-53210	651-328-3306 FLPD 2218	VERIZON WIRELESS	VERIZON WIRELESS SEP 11 - OCT 10 2025	40.01	2528
101-42-2100-53210	651-392-3228 FTO IPAD	VERIZON WIRELESS	VERIZON WIRELESS SEP 11 - OCT 10 2025	20.02	2528
101-42-2100-53210	651-392-3229 FTO IPAD 2	VERIZON WIRELESS	VERIZON WIRELESS SEP 11 - OCT 10 2025	20.02	2528
101-42-2100-53210	651-396-1879 SQUAD 2014	VERIZON WIRELESS	VERIZON WIRELESS SEP 11 - OCT 10 2025	40.03	2528
101-42-2100-53210	651-396-2124 SQUAD 2011	VERIZON WIRELESS	VERIZON WIRELESS SEP 11 - OCT 10 2025	40.01	2528
101-42-2100-53210	952-529-0340 FLPD FL2104	VERIZON WIRELESS	VERIZON WIRELESS SEP 11 - OCT 10 2025	40.01	2528
101-42-2100-53210	952-529-1078 FLPD FL2310	VERIZON WIRELESS	VERIZON WIRELESS SEP 11 - OCT 10 2025	40.01	2528
101-42-2100-53210	952-529-1105 FLPD FL2115	VERIZON WIRELESS	VERIZON WIRELESS SEP 11 - OCT 10 2025	40.01	2528
101-42-2100-53210	952-529-5231 FLPD FL2014	VERIZON WIRELESS	VERIZON WIRELESS SEP 11 - OCT 10 2025	40.01	2528
101-42-2100-53210	952-529-6879 FLPD FL2016	VERIZON WIRELESS	VERIZON WIRELESS SEP 11 - OCT 10 2025	40.01	2528
101-42-2100-53210	952-693-6441 FLPD FL2319	VERIZON WIRELESS	VERIZON WIRELESS SEP 11 - OCT 10 2025	40.01	2528
101-42-2100-53210	952-324-6894 FLPD FL2003	VERIZON WIRELESS	VERIZON WIRELESS SEP 11 - OCT 10 2025	40.01	2528
101-42-2100-53210	651-358-0723 J. WENSMANN	VERIZON WIRELESS	VERIZON WIRELESS SEP 11 - OCT 10 2025	38.41	2528
101-42-2100-53210	651-358-0814 J. PELTIER	VERIZON WIRELESS	VERIZON WIRELESS SEP 11 - OCT 10 2025	38.41	2528
101-42-2100-53210	763-215-7569 J. CISNEROS	VERIZON WIRELESS	VERIZON WIRELESS SEP 11 - OCT 10 2025	38.41	2528
101-42-2100-53210	763-215-7570 N. MEDLEY	VERIZON WIRELESS	VERIZON WIRELESS SEP 11 - OCT 10 2025	38.41	2528
101-42-2100-53210	651-416-9595 A. CINELLI	VERIZON WIRELESS	VERIZON WIRELESS SEP 11 - OCT 10 2025	38.41	2528
101-42-2100-53210	651-416-9599 C. DEL GROSSO	VERIZON WIRELESS	VERIZON WIRELESS SEP 11 - OCT 10 2025	38.41	2528
101-42-2100-53210	651-392-2791 T. CARPENTER	VERIZON WIRELESS	VERIZON WIRELESS SEP 11 - OCT 10 2025	38.41	2528
101-42-2400-53210	651-302-1162 N. MOATS	VERIZON WIRELESS	VERIZON WIRELESS SEP 11 - OCT 10 2025	38.41	2528
101-43-3100-53210	612-368-1369 M. CAPRA	VERIZON WIRELESS	VERIZON WIRELESS SEP 11 - OCT 10 2025	38.41	2528
101-43-3100-53210	651-245-5102 D. ZIEHL	VERIZON WIRELESS	VERIZON WIRELESS SEP 11 - OCT 10 2025	38.41	2528
101-43-3100-53210	651-272-6865 C. ANDERSON	VERIZON WIRELESS	VERIZON WIRELESS SEP 11 - OCT 10 2025	38.41	2528
101-43-3100-53210	612-518-1424 PUBLIC WORKS TRUCK 123	VERIZON WIRELESS	VERIZON WIRELESS SEP 11 - OCT 10 2025	40.01	2528
101-43-3100-53210	651-319-3206 M. SWENSON	VERIZON WIRELESS	VERIZON WIRELESS SEP 11 - OCT 10 2025	38.41	2528
101-43-3100-53210	651-755-1225 M. WELSH	VERIZON WIRELESS	VERIZON WIRELESS SEP 11 - OCT 10 2025	38.41	2528
101-43-3100-53210	651-755-1207 D. ADAMS	VERIZON WIRELESS	VERIZON WIRELESS SEP 11 - OCT 10 2025	38.41	2528
101-43-3100-53210	651-755-1171 K. LAWRENCE	VERIZON WIRELESS	VERIZON WIRELESS SEP 11 - OCT 10 2025	38.41	2528
101-43-3100-53210	651-706-3096 A. RAUCHBAUER	VERIZON WIRELESS	VERIZON WIRELESS SEP 11 - OCT 10 2025	38.41	2528
101-43-3100-53210	651-396-8432 D. ANDERSON	VERIZON WIRELESS	VERIZON WIRELESS SEP 11 - OCT 10 2025	38.41	2528
101-45-5120-53210	952-999-1684 K. YOUNG	VERIZON WIRELESS	VERIZON WIRELESS SEP 11 - OCT 10 2025	38.41	2528
101-45-5200-53210	651-368-2552 FL PARKS	VERIZON WIRELESS	VERIZON WIRELESS SEP 11 - OCT 10 2025	38.41	2528
101-45-5200-53210	651-368-2550 K. WERNER	VERIZON WIRELESS	VERIZON WIRELESS SEP 11 - OCT 10 2025	38.41	2528
101-45-5200-53210	651-350-9271 M. OLSON	VERIZON WIRELESS	VERIZON WIRELESS SEP 11 - OCT 10 2025	38.41	2528
205-43-3150-53210	651-350-9187 PUBLIC WORKS JETPACK	VERIZON WIRELESS	VERIZON WIRELESS SEP 11 - OCT 10 2025	20.02	2528
205-43-3150-53210	651-470-1692 PUBLIC WORKS JETPACK	VERIZON WIRELESS	VERIZON WIRELESS SEP 11 - OCT 10 2025	40.01	2528
631-49-9440-53210	651-755-1215 C. PRICKETT	VERIZON WIRELESS	VERIZON WIRELESS SEP 11 - OCT 10 2025	38.41	2528
631-49-9440-53210	651-755-1233 J. FASBENDER	VERIZON WIRELESS	VERIZON WIRELESS SEP 11 - OCT 10 2025	38.41	2528
631-49-9440-53210	651-242-8901 J. BARCHENGER	VERIZON WIRELESS	VERIZON WIRELESS SEP 11 - OCT 10 2025	38.41	2528
631-49-9440-53210	952-256-6340 S. WATER DEPT	VERIZON WIRELESS	VERIZON WIRELESS SEP 11 - OCT 10 2025	40.01	2528
631-49-9440-53210	952-256-6472 N. WATER DEPT	VERIZON WIRELESS	VERIZON WIRELESS SEP 11 - OCT 10 2025	40.01	2528
631-49-9440-53210	612-759-1222 PUBLIC WORKS 2	VERIZON WIRELESS	VERIZON WIRELESS SEP 11 - OCT 10 2025	40.01	2528
631-49-9440-53210	651-350-9188 PUBLIC WORKS TRUCK 115	VERIZON WIRELESS	VERIZON WIRELESS SEP 11 - OCT 10 2025	40.01	2528
631-49-9440-53210	651-328-0006 A. MORRIS-KARL	VERIZON WIRELESS	VERIZON WIRELESS SEP 11 - OCT 10 2025	38.41	2528
631-49-9440-53210	612-368-1380 M. BURG	VERIZON WIRELESS	VERIZON WIRELESS SEP 11 - OCT 10 2025	38.41	2528
631-49-9440-53210	763-402-6826 J. NAPIERALA	VERIZON WIRELESS	VERIZON WIRELESS SEP 11 - OCT 10 2025	38.41	2528
632-49-9490-53210	651-350-9276 D. SCHREIER	VERIZON WIRELESS	VERIZON WIRELESS SEP 11 - OCT 10 2025	38.41	2528
632-49-9490-53210	651-350-9189 WATER PLANT 1	VERIZON WIRELESS	VERIZON WIRELESS SEP 11 - OCT 10 2025	40.01	2528
632-49-9490-53210	612-759-5986 PUBLIC WORKS 126	VERIZON WIRELESS	VERIZON WIRELESS SEP 11 - OCT 10 2025	40.01	2528
		Total For Check 2528		<u>3,765.04</u>	
Check 2529					
101-41-1320-53210	651-418-0827 M. STATZ	VERIZON WIRELESS	VERIZON WIRELESS OCT 11 - NOV 10 2025	38.41	2529

101-41-1320-53210	651-262-9618 J. CHAIKA	VERIZON WIRELESS	VERIZON WIRELESS OCT 11 - NOV 10 2025	38.41	2529
101-41-1910-53210	651-418-3960 A. WITTMAN	VERIZON WIRELESS	VERIZON WIRELESS OCT 11 - NOV 10 2025	38.41	2529
101-41-1940-53210	651-755-1235 D. FLOHR	VERIZON WIRELESS	VERIZON WIRELESS OCT 11 - NOV 10 2025	38.41	2529
101-41-1940-53210	651-368-2551 D. HAIDER	VERIZON WIRELESS	VERIZON WIRELESS OCT 11 - NOV 10 2025	48.69	2529
101-42-2100-53210	952-324-6894 FLPD FL2003	VERIZON WIRELESS	VERIZON WIRELESS OCT 11 - NOV 10 2025	40.01	2529
101-42-2100-53210	651-416-9595 A. CINELLI	VERIZON WIRELESS	VERIZON WIRELESS OCT 11 - NOV 10 2025	38.41	2529
101-42-2100-53210	651-416-9599 C. DEL GROSSO	VERIZON WIRELESS	VERIZON WIRELESS OCT 11 - NOV 10 2025	38.41	2529
101-42-2100-53210	651-302-3584 A. LEWERENCE	VERIZON WIRELESS	VERIZON WIRELESS OCT 11 - NOV 10 2025	46.81	2529
101-42-2100-53210	651-302-9539 H. BELKA	VERIZON WIRELESS	VERIZON WIRELESS OCT 11 - NOV 10 2025	46.81	2529
101-42-2100-53210	763-301-4526 L. HANEGRAAF	VERIZON WIRELESS	VERIZON WIRELESS OCT 11 - NOV 10 2025	40.01	2529
101-42-2100-53210	763-301-4556 L. HANEGRAAF	VERIZON WIRELESS	VERIZON WIRELESS OCT 11 - NOV 10 2025	40.01	2529
101-42-2100-53210	763-341-0274 FLPD FL2002	VERIZON WIRELESS	VERIZON WIRELESS OCT 11 - NOV 10 2025	40.01	2529
101-42-2100-53210	763-401-2179 T. SCHIMMELMAN	VERIZON WIRELESS	VERIZON WIRELESS OCT 11 - NOV 10 2025	38.41	2529
101-42-2100-53210	651-421-6901 L. HANEGRAAF	VERIZON WIRELESS	VERIZON WIRELESS OCT 11 - NOV 10 2025	40.01	2529
101-42-2100-53210	651-755-1203 B. DEGROOT	VERIZON WIRELESS	VERIZON WIRELESS OCT 11 - NOV 10 2025	38.41	2529
101-42-2100-53210	651-470-3439 401 PD JETPACK	VERIZON WIRELESS	VERIZON WIRELESS OCT 11 - NOV 10 2025	40.01	2529
101-42-2100-53210	651-478-0136 SEWER/WATER DEPT IPAD	VERIZON WIRELESS	VERIZON WIRELESS OCT 11 - NOV 10 2025	20.02	2529
101-42-2100-53210	651-478-0669 C. JOHNSON	VERIZON WIRELESS	VERIZON WIRELESS OCT 11 - NOV 10 2025	38.41	2529
101-42-2100-53210	651-509-4536 SQUAD 2005	VERIZON WIRELESS	VERIZON WIRELESS OCT 11 - NOV 10 2025	40.01	2529
101-42-2100-53210	651-724-2090 A. YATES	VERIZON WIRELESS	VERIZON WIRELESS OCT 11 - NOV 10 2025	38.41	2529
101-42-2100-53210	651-724-5578 T. COULTER	VERIZON WIRELESS	VERIZON WIRELESS OCT 11 - NOV 10 2025	38.41	2529
101-42-2100-53210	651-724-8880 J. BROWN	VERIZON WIRELESS	VERIZON WIRELESS OCT 11 - NOV 10 2025	38.41	2529
101-42-2100-53210	763-215-7569 J. CISNEROS	VERIZON WIRELESS	VERIZON WIRELESS OCT 11 - NOV 10 2025	38.41	2529
101-42-2100-53210	763-215-7570 N. MEDLEY	VERIZON WIRELESS	VERIZON WIRELESS OCT 11 - NOV 10 2025	38.41	2529
101-42-2100-53210	651-392-2791 T. CARPENTER	VERIZON WIRELESS	VERIZON WIRELESS OCT 11 - NOV 10 2025	38.41	2529
101-42-2100-53210	952-324-6046 FLPD FL2013	VERIZON WIRELESS	VERIZON WIRELESS OCT 11 - NOV 10 2025	40.01	2529
101-42-2100-53210	952-324-6052 FLPD FL2011	VERIZON WIRELESS	VERIZON WIRELESS OCT 11 - NOV 10 2025	40.01	2529
101-42-2100-53210	952-324-6141 FLPD FL2005	VERIZON WIRELESS	VERIZON WIRELESS OCT 11 - NOV 10 2025	40.01	2529
101-42-2100-53210	952-324-6152 FLPD FL2208	VERIZON WIRELESS	VERIZON WIRELESS OCT 11 - NOV 10 2025	40.01	2529
101-42-2100-53210	952-324-6229 FLPD FL1809	VERIZON WIRELESS	VERIZON WIRELESS OCT 11 - NOV 10 2025	40.01	2529
101-42-2100-53210	952-529-0340 FLPD FL2104	VERIZON WIRELESS	VERIZON WIRELESS OCT 11 - NOV 10 2025	40.01	2529
101-42-2100-53210	952-529-1078 FLPD FL2310	VERIZON WIRELESS	VERIZON WIRELESS OCT 11 - NOV 10 2025	40.01	2529
101-42-2100-53210	952-529-1105 FLPD FL2115	VERIZON WIRELESS	VERIZON WIRELESS OCT 11 - NOV 10 2025	40.01	2529
101-42-2100-53210	952-529-5231 FLPD FL2014	VERIZON WIRELESS	VERIZON WIRELESS OCT 11 - NOV 10 2025	40.01	2529
101-42-2100-53210	952-529-6879 FLPD FL2016	VERIZON WIRELESS	VERIZON WIRELESS OCT 11 - NOV 10 2025	40.01	2529
101-42-2100-53210	952-693-6441 FLPD FL2319	VERIZON WIRELESS	VERIZON WIRELESS OCT 11 - NOV 10 2025	40.01	2529
101-42-2100-53210	651-358-0723 J. WENSMANN	VERIZON WIRELESS	VERIZON WIRELESS OCT 11 - NOV 10 2025	38.41	2529
101-42-2100-53210	651-358-0814 J. PELTIER	VERIZON WIRELESS	VERIZON WIRELESS OCT 11 - NOV 10 2025	38.41	2529
101-42-2100-53210	651-318-7476 FLPD FL2012	VERIZON WIRELESS	VERIZON WIRELESS OCT 11 - NOV 10 2025	40.01	2529
101-42-2100-53210	651-392-3228 FTO IPAD	VERIZON WIRELESS	VERIZON WIRELESS OCT 11 - NOV 10 2025	20.02	2529
101-42-2100-53210	651-392-3229 FTO IPAD 2	VERIZON WIRELESS	VERIZON WIRELESS OCT 11 - NOV 10 2025	20.02	2529
101-42-2100-53210	651-396-1879 SQUAD 2014	VERIZON WIRELESS	VERIZON WIRELESS OCT 11 - NOV 10 2025	40.01	2529
101-42-2100-53210	651-396-2124 SQUAD 2011	VERIZON WIRELESS	VERIZON WIRELESS OCT 11 - NOV 10 2025	40.01	2529
101-42-2100-53210	651-396-2613 SQUAD 2208	VERIZON WIRELESS	VERIZON WIRELESS OCT 11 - NOV 10 2025	40.01	2529
101-42-2100-53210	651-396-3298 SQUAD 1809	VERIZON WIRELESS	VERIZON WIRELESS OCT 11 - NOV 10 2025	40.01	2529
101-42-2100-53210	651-396-4966 SQUAD 2416	VERIZON WIRELESS	VERIZON WIRELESS OCT 11 - NOV 10 2025	40.01	2529
101-42-2100-53210	651-325-6426 R. PETERSON	VERIZON WIRELESS	VERIZON WIRELESS OCT 11 - NOV 10 2025	38.41	2529
101-42-2100-53210	651-325-6588 M. RICHERT	VERIZON WIRELESS	VERIZON WIRELESS OCT 11 - NOV 10 2025	38.41	2529
101-42-2100-53210	651-325-6589 N. KENT	VERIZON WIRELESS	VERIZON WIRELESS OCT 11 - NOV 10 2025	38.41	2529
101-42-2100-53210	651-325-6590 J. AYERS	VERIZON WIRELESS	VERIZON WIRELESS OCT 11 - NOV 10 2025	38.41	2529
101-42-2100-53210	651-325-6591 S. LAFFERTY	VERIZON WIRELESS	VERIZON WIRELESS OCT 11 - NOV 10 2025	38.41	2529
101-42-2100-53210	651-325-6593 J. GLADER	VERIZON WIRELESS	VERIZON WIRELESS OCT 11 - NOV 10 2025	38.41	2529
101-42-2100-53210	651-325-6594 R. WARKE	VERIZON WIRELESS	VERIZON WIRELESS OCT 11 - NOV 10 2025	38.41	2529
101-42-2100-53210	651-325-6595 T. MEYER	VERIZON WIRELESS	VERIZON WIRELESS OCT 11 - NOV 10 2025	38.41	2529
101-42-2100-53210	651-325-6597 M. KARNES	VERIZON WIRELESS	VERIZON WIRELESS OCT 11 - NOV 10 2025	38.41	2529
101-42-2100-53210	651-325-6598 T. COKCBURN	VERIZON WIRELESS	VERIZON WIRELESS OCT 11 - NOV 10 2025	38.41	2529
101-42-2100-53210	651-248-5838 N. CARLSON	VERIZON WIRELESS	VERIZON WIRELESS OCT 11 - NOV 10 2025	38.41	2529
101-42-2100-53210	651-328-3306 FLPD 2218	VERIZON WIRELESS	VERIZON WIRELESS OCT 11 - NOV 10 2025	40.01	2529

101-42-2100-53210	612-231-7428 N. OLSTAD	VERIZON WIRELESS	VERIZON WIRELESS OCT 11 - NOV 10 2025	38.41	2529
101-42-2100-53210	612-391-5880 L. HANEGRAFF	VERIZON WIRELESS	VERIZON WIRELESS OCT 11 - NOV 10 2025	38.41	2529
101-42-2100-53210	612-419-1365 J. GRIFFIN	VERIZON WIRELESS	VERIZON WIRELESS OCT 11 - NOV 10 2025	38.41	2529
101-42-2100-53210	612-463-9664 O. RUDE	VERIZON WIRELESS	VERIZON WIRELESS OCT 11 - NOV 10 2025	38.41	2529
101-42-2100-53210	612-494-2962 FLPD 2319	VERIZON WIRELESS	VERIZON WIRELESS OCT 11 - NOV 10 2025	40.01	2529
101-42-2100-53210	612-581-6901 SQUAD 2012	VERIZON WIRELESS	VERIZON WIRELESS OCT 11 - NOV 10 2025	40.01	2529
101-42-2100-53210	612-581-7139 SQUAD 2104	VERIZON WIRELESS	VERIZON WIRELESS OCT 11 - NOV 10 2025	40.01	2529
101-42-2100-53210	612-581-7480 SQUAD 2319	VERIZON WIRELESS	VERIZON WIRELESS OCT 11 - NOV 10 2025	40.01	2529
101-42-2100-53210	612-581-7507 SQUAD 2115	VERIZON WIRELESS	VERIZON WIRELESS OCT 11 - NOV 10 2025	40.03	2529
101-42-2100-53210	612-581-7573 SQUAD 2013	VERIZON WIRELESS	VERIZON WIRELESS OCT 11 - NOV 10 2025	40.01	2529
101-42-2100-53210	612-581-8423 SQUAD 2107	VERIZON WIRELESS	VERIZON WIRELESS OCT 11 - NOV 10 2025	40.01	2529
101-42-2400-53210	651-302-1162 N. MOATS	VERIZON WIRELESS	VERIZON WIRELESS OCT 11 - NOV 10 2025	38.41	2529
101-43-3100-53210	651-755-1225 M. WELSH	VERIZON WIRELESS	VERIZON WIRELESS OCT 11 - NOV 10 2025	38.41	2529
101-43-3100-53210	651-755-1171 K. LAWRENCE	VERIZON WIRELESS	VERIZON WIRELESS OCT 11 - NOV 10 2025	38.41	2529
101-43-3100-53210	651-706-3096 A. RAUCHBAUER	VERIZON WIRELESS	VERIZON WIRELESS OCT 11 - NOV 10 2025	38.41	2529
101-43-3100-53210	651-755-1207 D. ADAMS	VERIZON WIRELESS	VERIZON WIRELESS OCT 11 - NOV 10 2025	38.41	2529
101-43-3100-53210	651-245-5102 D. ZIEHL	VERIZON WIRELESS	VERIZON WIRELESS OCT 11 - NOV 10 2025	(8.40)	2529
101-43-3100-53210	651-272-6865 C. ANDERSON	VERIZON WIRELESS	VERIZON WIRELESS OCT 11 - NOV 10 2025	38.41	2529
101-43-3100-53210	651-396-8432 D. ANDERSON	VERIZON WIRELESS	VERIZON WIRELESS OCT 11 - NOV 10 2025	38.41	2529
101-43-3100-53210	651-319-3206 M. SWENSON	VERIZON WIRELESS	VERIZON WIRELESS OCT 11 - NOV 10 2025	38.41	2529
101-43-3100-53210	612-518-1424 PUBLIC WORKS TRUCK 123	VERIZON WIRELESS	VERIZON WIRELESS OCT 11 - NOV 10 2025	40.01	2529
101-43-3100-53210	612-368-1369 M. CAPRA	VERIZON WIRELESS	VERIZON WIRELESS OCT 11 - NOV 10 2025	38.41	2529
101-45-5120-53210	952-999-1684 K. YOUNG	VERIZON WIRELESS	VERIZON WIRELESS OCT 11 - NOV 10 2025	38.41	2529
101-45-5200-53210	651-350-9271 M. OLSON	VERIZON WIRELESS	VERIZON WIRELESS OCT 11 - NOV 10 2025	38.41	2529
101-45-5200-53210	651-368-2550 K. WERNER	VERIZON WIRELESS	VERIZON WIRELESS OCT 11 - NOV 10 2025	38.41	2529
101-45-5200-53210	651-368-2552 FL PARKS	VERIZON WIRELESS	VERIZON WIRELESS OCT 11 - NOV 10 2025	38.41	2529
205-43-3150-53210	651-470-1692 PUBLIC WORKS JETPACK	VERIZON WIRELESS	VERIZON WIRELESS OCT 11 - NOV 10 2025	40.01	2529
205-43-3150-53210	651-350-9187 PUBLIC WORKS JETPACK	VERIZON WIRELESS	VERIZON WIRELESS OCT 11 - NOV 10 2025	20.02	2529
631-49-9440-53210	651-755-1215 C. PRICKETT	VERIZON WIRELESS	VERIZON WIRELESS OCT 11 - NOV 10 2025	38.41	2529
631-49-9440-53210	952-256-6340 S. WATER DEPT	VERIZON WIRELESS	VERIZON WIRELESS OCT 11 - NOV 10 2025	40.01	2529
631-49-9440-53210	952-256-6472 N. WATER DEPT	VERIZON WIRELESS	VERIZON WIRELESS OCT 11 - NOV 10 2025	40.01	2529
631-49-9440-53210	651-755-1233 J. FASBENDER	VERIZON WIRELESS	VERIZON WIRELESS OCT 11 - NOV 10 2025	38.41	2529
631-49-9440-53210	763-402-6826 J. NAPIERALA	VERIZON WIRELESS	VERIZON WIRELESS OCT 11 - NOV 10 2025	38.41	2529
631-49-9440-53210	651-350-9188 PUBLIC WORKS TRUCK 115	VERIZON WIRELESS	VERIZON WIRELESS OCT 11 - NOV 10 2025	40.01	2529
631-49-9440-53210	651-328-0006 A. MORRIS-KARL	VERIZON WIRELESS	VERIZON WIRELESS OCT 11 - NOV 10 2025	38.41	2529
631-49-9440-53210	612-368-1380 M. BURG	VERIZON WIRELESS	VERIZON WIRELESS OCT 11 - NOV 10 2025	38.41	2529
631-49-9440-53210	651-242-8901 J. BARCHENGER	VERIZON WIRELESS	VERIZON WIRELESS OCT 11 - NOV 10 2025	38.41	2529
631-49-9440-53210	612-759-1222 PUBLIC WORKS 2	VERIZON WIRELESS	VERIZON WIRELESS OCT 11 - NOV 10 2025	40.01	2529
632-49-9490-53210	612-759-5986 PUBLIC WORKS 126	VERIZON WIRELESS	VERIZON WIRELESS OCT 11 - NOV 10 2025	40.01	2529
632-49-9490-53210	651-350-9189 WATER PLANT 1	VERIZON WIRELESS	VERIZON WIRELESS OCT 11 - NOV 10 2025	40.01	2529
632-49-9490-53210	651-350-9276 D. SCHREIER	VERIZON WIRELESS	VERIZON WIRELESS OCT 11 - NOV 10 2025	38.41	2529
		Total For Check 2529		<u>3,811.73</u>	
Check 2531					
101-00-0000-21713	DENTAL INSURANCE PAYABLE	HEALTH PARTNERS	HEALTH PARTNERS PREMIUM - DECEMBER 2025	<u>708.92</u>	2531
		Total For Check 2531		708.92	
Check 2532					
101-00-0000-21713	DENTAL INSURANCE PAYABLE	HEALTH PARTNERS	HPAI SELF INSURED CLAIMS 15657 - NOVEMBER 2025	<u>2,467.41</u>	2532
		Total For Check 2532		2,467.41	
Check 2533					
101-00-0000-21713	DENTAL INSURANCE PAYABLE	HEALTH PARTNERS	HPAI SELF INSURED CLAIMS 15657 - DECEMBER 2025	<u>518.42</u>	2533
		Total For Check 2533		518.42	
Check 2534					
101-42-2400-53100	PROF SERVICES - OTHER	INVOICE CLOUD INC	INVOICE CLOUD PAYMENT FEES - NOVEMBER 2025	29.99	2534

205-43-3190-53070	SURFACE ADM/PROFESSIONAL SERVICES	INVOICE CLOUD INC	INVOICE CLOUD PAYMENT FEES - NOVEMBER 2025	1,051.20	2534
631-49-9490-53070	SEWER ADM/PROFESSIONAL SERVICE	INVOICE CLOUD INC	INVOICE CLOUD PAYMENT FEES - NOVEMBER 2025	4,730.40	2534
632-49-9490-53070	PROFESSIONAL SERVICES	INVOICE CLOUD INC	INVOICE CLOUD PAYMENT FEES - NOVEMBER 2025	4,730.40	2534
		Total For Check 2534		<u>10,541.99</u>	
Check 2535					
101-46-6625-53210	TELEPHONE	CENTURY LINK	SENIOR CENTER TELEPHONE - NOVEMBER 2025	147.68	2535
		Total For Check 2535		<u>147.68</u>	
Check 2536					
101-41-1400-54370	POSTIVE PAY MONTHLY FEE-DECEMBER	MIDWESTONE BANK	POSITIVE PAY MONTHLY FEE-DECEMBER	59.15	2536
		Total For Check 2536		<u>59.15</u>	
Check 2537					
205-43-3150-53070	PROFESSIONAL SERVICES	CHASE PAYMENTECH	SERVICE FEE PAYMENTS-DECEMBER UB	414.71	2537
631-49-9440-53070	PROFESSIONAL SERVICES	CHASE PAYMENTECH	SERVICE FEE PAYMENTS-DECEMBER UB	1,866.16	2537
632-49-9490-53070	PROFESSIONAL SERVICES	CHASE PAYMENTECH	SERVICE FEE PAYMENTS-DECEMBER UB	1,866.16	2537
		Total For Check 2537		<u>4,147.03</u>	
Check 2538					
632-49-9450-53810	ELECTRIC UTILITIES	XCEL ENERGY	51-0012039653-5/4938 HEADWATERS PKWY	33.04	2538
		Total For Check 2538		<u>33.04</u>	
Check 2539					
101-45-5200-53810	ELECTRIC UTILITIES	XCEL ENERGY	51-8383920-1 ~ 5515 - 206TH ST -PARK WELL	381.10	2539
		Total For Check 2539		<u>381.10</u>	
Check 2540					
101-43-3160-53810	ELECTRIC UTILITIES	XCEL ENERGY	51-0239645-4 ~ 777 WEST BROADWAY AVE-ELEC	32.29	2540
101-43-3160-53810	ELECTRIC UTILITIES	XCEL ENERGY	51-0239647-6 ~ 1198 W BROADWAY AVE-TRAFFIC	40.22	2540
101-43-3160-53810	ELECTRIC UTILITIES	XCEL ENERGY	51-0239648-7 ~ 775 WEST BROADWAY AVE-ELEC	36.63	2540
101-43-3160-53810	ELECTRIC UTILITIES	XCEL ENERGY	51-0239654-5 ~ 797 WEST BROADWAY AVE-ELEC	32.82	2540
101-43-3160-53810	ELECTRIC UTILITIES	XCEL ENERGY	51-0239656-7 ~ 795 WEST BROADWAY AVE-ELEC	34.11	2540
101-43-3160-53810	ELECTRIC UTILITIES	XCEL ENERGY	51-0239659-0 ~ 1493 W BROADWAY AVE-TRAFFIC	36.25	2540
101-43-3160-53810	ELECTRIC UTILITIES	XCEL ENERGY	51-0677899-8 ~ 20010 FERN GLEN LN N-STREET	21.83	2540
101-43-3160-53810	ELECTRIC UTILITIES	XCEL ENERGY	51-0677908-0 ~ 20066 FERN GLEN LN N-STREET	20.06	2540
101-43-3160-53810	ELECTRIC UTILITIES	XCEL ENERGY	51-5193665-5 ~ 49 LAKE ST N-STREET	7,384.78	2540
101-43-3160-53810	ELECTRIC UTILITIES	XCEL ENERGY	51-7342887-2 ~ 5295 SCANDIA TR N-TRAFFIC	24.49	2540
101-43-3160-53810	ELECTRIC UTILITIES	XCEL ENERGY	51-0010257806-0 ~ 20187 FERN GLEN BLVD N-S	19.50	2540
101-43-3160-53810	ELECTRIC UTILITIES	XCEL ENERGY	51-0010258367-0 ~ 20116 FERN GLEN CT N - STREET	19.42	2540
101-43-3160-53810	ELECTRIC UTILITIES	XCEL ENERGY	51-0011646952-3 ~ 1872 FOREST BLVD	11.19	2540
101-43-3160-53810	ELECTRIC UTILITIES	XCEL ENERGY	51-0012332089-3 ~ 204 LAKE STREET N UNIT-TRAFFIC	24.44	2540
101-43-3160-53810	ELECTRIC UTILITIES	XCEL ENERGY	51-0013225636-0 ~ 6358 SCANDIA TRL N	14.86	2540
101-43-3180-53810	ELECTRIC UTILITIES	XCEL ENERGY	51-5193666-6 ~ CITY GARAGE	676.53	2540
101-43-3180-53810	ELECTRIC UTILITIES	XCEL ENERGY	51-5193671-3 ~ PUBLIC WORKS FACILITY	286.90	2540
101-45-5200-53810	ELECTRIC UTILITIES	XCEL ENERGY	51-5193667-7 ~ BEACH HOUSE	323.88	2540
101-45-5200-53810	ELECTRIC UTILITIES	XCEL ENERGY	51-5193668-8 ~ 720 - 11TH AVE SE-ICE	109.25	2540
101-46-6625-53810	ELECTRIC UTILITIES	XCEL ENERGY	51-0013429969-4 ~ 767 4TH ST SW	735.72	2540
631-49-9420-53810	ELECTRIC UTILITIES	XCEL ENERGY	51-5193670-2 ~ 456 3RD ST NW-PUMP	1,920.65	2540
631-49-9420-53810	ELECTRIC UTILITIES	XCEL ENERGY	51-5193676-8 ~ 1850 8TH ST SE & 65 3RD AVE NW WTP	5,064.34	2540
631-49-9420-53810	ELECTRIC UTILITIES	XCEL ENERGY	51-8919722-8 ~ 208 8TH ST NW - TOWER	192.47	2540
631-49-9420-53810	ELECTRIC UTILITIES	XCEL ENERGY	51-0013971904-6 ~ 6195 210TH ST N	415.11	2540
632-49-9450-53810	ELECTRIC UTILITIES	XCEL ENERGY	51-9828587-1 ~ 97 BROADWAY AVE W - TRAFFIC	90.57	2540
632-49-9450-53810	ELECTRIC UTILITIES	XCEL ENERGY	51-0010257805-9 ~ 20126 FERN GLEN CT N-STR	19.26	2540
		Total For Check 2540		<u>17,587.57</u>	
Check 2541					

101-41-1940-53810	ELECTRIC UTILITIES	XCEL ENERGY	51-5193661-1 ~ GOVMNT BLDG	598.14	2541
101-43-3160-53810	ELECTRIC UTILITIES	XCEL ENERGY	51-0013131153-7 ~ 10100 SCANDIA TRL N	26.24	2541
632-49-9450-53810	ELECTRIC UTILITIES	XCEL ENERGY	51-0830223-8 ~ 6728 NORTH SHORE TRL N-ELEC	12.58	2541
632-49-9450-53810	ELECTRIC UTILITIES	XCEL ENERGY	51-8829533-8 ~ 21036 KAROLINE CT N-LIFT	38.93	2541
632-49-9450-53810	ELECTRIC UTILITIES	XCEL ENERGY	51-0012384369-1 ~ 7865 SCANDIA TRL N	37.49	2541
632-49-9450-53810	ELECTRIC UTILITIES	XCEL ENERGY	51-0014003458-5 7686 NORTH SHORE CIR LIFT STATION	30.93	2541
632-49-9450-53810	ELECTRIC UTILITIES	XCEL ENERGY	51-0014224434-5 ~ 21228 KIEBLER CT N	19.30	2541
		Total For Check 2541		<u>763.61</u>	
Check 2542					
101-41-1320-52010	Office Door Signs	BANK OF MONTREAL - BMO	Office Door Signs	24.99	2542
101-41-1320-52010	Large Cork Bulletin Board	BANK OF MONTREAL - BMO	Large Cork Bulletin Board	135.90	2542
101-41-1400-52010	Thermal Lamination Film Roll	BANK OF MONTREAL - BMO	Thermal Lamination Film Roll	37.38	2542
101-41-1400-52010	3 wireless keyboard and mouse	BANK OF MONTREAL - BMO	3 wireless keyboard and mouse	85.47	2542
101-41-1400-53080	Refund for MNGFOA Conference	BANK OF MONTREAL - BMO	Refund for MNGFOA Conference	(250.00)	2542
101-41-1500-52100	HDMI cords	BANK OF MONTREAL - BMO	Fall Range Training - Water	37.15	2542
101-41-1500-52100	Monthly MailChimp subscription	BANK OF MONTREAL - BMO	Monthly MailChimp subscription	26.50	2542
101-41-1910-53520	Recording of Interstate Agreements	BANK OF MONTREAL - BMO	Recording of Interstate Agreements	57.18	2542
101-42-2100-52010	Supplies and organization	BANK OF MONTREAL - BMO	Supplies and organization	137.99	2542
101-42-2100-52010	OFFICE SUPPLIES	BANK OF MONTREAL - BMO	OFFICE SUPPLIES	189.99	2542
101-42-2100-52010	Return	BANK OF MONTREAL - BMO	Return	(69.87)	2542
101-42-2100-52010	SRO Dual Monitors	BANK OF MONTREAL - BMO	SRO Dual Monitors	66.48	2542
101-42-2100-52010	Notary - J. Griffin	BANK OF MONTREAL - BMO	Notary - J. Griffin	120.00	2542
101-42-2100-52010	Office Supplies	BANK OF MONTREAL - BMO	Office Supplies	105.92	2542
101-42-2100-52010	Notary Stamp - J. Griffin	BANK OF MONTREAL - BMO	Notary Stamp - J. Griffin	29.22	2542
101-42-2100-52020	First Responder Alert Stickers	BANK OF MONTREAL - BMO	First Responder Alert Stickers	44.24	2542
101-42-2100-52100	Rifle Optics Batteries	BANK OF MONTREAL - BMO	Rifle Optics Batteries	20.56	2542
101-42-2100-52100	Safes for unmarked detective squad cars.	BANK OF MONTREAL - BMO	Safes for unmarked detective squad cars.	1,097.17	2542
101-42-2100-52100	Safe alert devices	BANK OF MONTREAL - BMO	Safe alert devices	450.00	2542
101-42-2100-52130	Returned police equipment not needed.	BANK OF MONTREAL - BMO	Returned police equipment not needed.	(47.66)	2542
101-42-2100-52130	Community Service Officers - Patches	BANK OF MONTREAL - BMO	Community Service Officers - Patches	57.00	2542
101-42-2100-52130	Refund for badge order	BANK OF MONTREAL - BMO	Refund for badge order	(55.00)	2542
101-42-2100-52130	AXON Signal side arm brackets/hardware	BANK OF MONTREAL - BMO	AXON Signal side arm brackets/hardware	32.45	2542
101-42-2100-52130	AXON BWC mounts	BANK OF MONTREAL - BMO	AXON Signal side arm brackets/hardware	68.00	2542
101-42-2100-52130	Replacement SRO Pants (A. Yates)	BANK OF MONTREAL - BMO	Replacement SRO Pants (A. Yates)	66.25	2542
101-42-2100-52210	Recurring monthly purchase Squad 2416	BANK OF MONTREAL - BMO	Recurring monthly purchase Squad 2416	35.75	2542
101-42-2100-52210	Recurring monthly purchase - Squad #2319	BANK OF MONTREAL - BMO	Recurring monthly purchase Squad 2416	35.75	2542
101-42-2100-52210	Recurring monthly purchase - \$2406	BANK OF MONTREAL - BMO	Recurring monthly purchase Squad 2416	35.75	2542
101-42-2100-52210	Recurring monthly purchase - Squad #2208	BANK OF MONTREAL - BMO	Recurring monthly purchase Squad 2416	35.75	2542
101-42-2100-52210	Recurring Monthly purchase - Squad #2012	BANK OF MONTREAL - BMO	Recurring monthly purchase Squad 2416	35.75	2542
101-42-2100-52210	Recurring monthly purchase - Squad #2013	BANK OF MONTREAL - BMO	Recurring monthly purchase Squad 2416	35.75	2542
101-42-2100-52210	Recurring monthly purchase - Squad #2011	BANK OF MONTREAL - BMO	Recurring monthly purchase Squad 2416	35.75	2542
101-42-2100-52210	Recurring monthly purchase - Squad #2118	BANK OF MONTREAL - BMO	Recurring monthly purchase Squad 2416	35.75	2542
101-42-2100-52210	Recurring monthly purchase - Squad #2504	BANK OF MONTREAL - BMO	Recurring monthly purchase Squad 2416	35.75	2542
101-42-2100-52210	Recurring monthly purchase - Squad #2104	BANK OF MONTREAL - BMO	Recurring monthly purchase Squad 2416	35.75	2542
101-42-2100-52210	Recurring monthly purchase - #2507	BANK OF MONTREAL - BMO	Recurring monthly purchase Squad 2416	35.75	2542
101-42-2100-52210	Recurring monthly purchase - #Squad #250	BANK OF MONTREAL - BMO	Recurring monthly purchase Squad 2416	35.75	2542
101-42-2100-53060	2025 Sgt promotion process/DISC personal	BANK OF MONTREAL - BMO	2025 Sgt promotion process/DISC personality testing	450.00	2542
101-42-2100-53080	In-House Training Lunch (Use of Force &	BANK OF MONTREAL - BMO	In-House Training Lunch (Use of Force & Range Training)	263.36	2542
101-42-2100-53080	Fall Range Training - Water	BANK OF MONTREAL - BMO	Fall Range Training - Water	10.94	2542
101-42-2100-53080	Training Expenses - Lunch for trainees/t	BANK OF MONTREAL - BMO	Fall Range Training - Water	19.98	2542
101-42-2100-53080	2025-IACP-CONFERENCE REGISTRATION	BANK OF MONTREAL - BMO	IACP Conference fee's.	500.00	2542
101-42-2100-53080	2025 MN Chiefs of Police leadership acad	BANK OF MONTREAL - BMO	2025 MN Chiefs of Police leadership academy. For newly promoted Sergeant	765.00	2542
101-42-2100-53080	Data Practices Training	BANK OF MONTREAL - BMO	Data Practices Training	175.00	2542
101-42-2100-53220	Overnight title to Guardian Public Safet	BANK OF MONTREAL - BMO	Overnight title to Guardian Public Safety.	31.40	2542
101-42-2100-53220	UPS for Taser	BANK OF MONTREAL - BMO	Overnight title to Guardian Public Safety.	7.16	2542
101-42-2100-54270	Registration for Tahoe	BANK OF MONTREAL - BMO	Registration for Tahoe	19.41	2542

101-42-2125-53520	Forest Lake Safety Camp Domain Name Sept	BANK OF MONTREAL - BMO	Forest Lake Safety Camp Domain Name September 09/11/-2025-10/10/2525	10.64	2542
101-42-2200-52100	Binders for new firefighter orientation.	BANK OF MONTREAL - BMO	Binders for new firefighter orientation.	46.99	2542
101-42-2200-52100	Plastic Totes for new firefighter equipm	BANK OF MONTREAL - BMO	Plastic Totes for new firefighter equipment.	81.00	2542
101-42-2200-52100	Yellow duct tape for physical agility te	BANK OF MONTREAL - BMO	Yellow duct tape for physical agility testing.	35.43	2542
101-42-2200-53080	IACP Conference fee's.	BANK OF MONTREAL - BMO	IACP Conference fee's.	700.00	2542
101-42-2200-53090	Less Annoying CRM for I-Pads.	BANK OF MONTREAL - BMO	Less Annoying CRM for I-Pads.	90.00	2542
101-42-2200-53210	IPad Monthly Charges for Fire	BANK OF MONTREAL - BMO	IPad Monthly Charges for Fire	514.88	2542
101-42-2200-54310	Fire prevention coloring books.	BANK OF MONTREAL - BMO	Fire prevention coloring books.	3,014.96	2542
101-42-2400-54330	ICC yearly subscription renewal	BANK OF MONTREAL - BMO	ICC yearly subscription renewal	170.00	2542
101-43-3100-52100	Coffee for shop	BANK OF MONTREAL - BMO	Fall Range Training - Water	60.72	2542
101-43-3100-54040	parts for pressure washer	BANK OF MONTREAL - BMO	parts for pressure washer	20.86	2542
101-43-3100-54040	side mirror for pickup	BANK OF MONTREAL - BMO	side mirror for pickup	75.85	2542
101-45-5120-54330	Survey Generator	BANK OF MONTREAL - BMO	Survey Generator	300.00	2542
101-45-5200-52100	replacement light and parts for Beltz	BANK OF MONTREAL - BMO	replacement light and parts for Beltz	91.97	2542
101-46-6625-54370	Supplies for the Senior Center	BANK OF MONTREAL - BMO	Supplies for the Senior Center	487.33	2542
631-49-9420-52100	coffee for shop	BANK OF MONTREAL - BMO	Rifle Optics Batteries	50.60	2542
631-49-9440-53220	Postage for water samples	BANK OF MONTREAL - BMO	Overnight title to Guardian Public Safety.	11.58	2542
632-49-9450-52100	coffee for shop	BANK OF MONTREAL - BMO	Rifle Optics Batteries	50.60	2542
		Total For Check 2542		<u>10,987.72</u>	
Check 2543					
101-41-1320-52010	Office supplies	BANK OF MONTREAL - BMO	Office supplies	(24.99)	2543
101-41-1320-52010	Office supplies	BANK OF MONTREAL - BMO	Office supplies	32.99	2543
101-41-1320-52010	Office supplies	BANK OF MONTREAL - BMO	Office supplies	8.71	2543
101-41-1320-52010	Office supplies	BANK OF MONTREAL - BMO	Office supplies	1,318.00	2543
101-41-1320-52010	Office supplies	BANK OF MONTREAL - BMO	Office supplies	38.38	2543
101-41-1320-52010	Office supplies	BANK OF MONTREAL - BMO	Office supplies	(135.90)	2543
101-41-1320-52010	Office supplies	BANK OF MONTREAL - BMO	Office supplies	271.80	2543
101-41-1320-54370	Commissions picnic supplies	BANK OF MONTREAL - BMO	Commissions picnic supplies	48.10	2543
101-41-1320-54370	Commission picnic supplies	BANK OF MONTREAL - BMO	Commissions picnic supplies	161.44	2543
101-41-1320-54370	Clearinghouse subscription for mandatory	BANK OF MONTREAL - BMO	Clearinghouse subscription for mandatory employment queries.	125.00	2543
101-41-1400-53080	GFOA Flight	BANK OF MONTREAL - BMO	GFOA Flight	252.92	2543
101-41-1400-53080	GFOA FLight	BANK OF MONTREAL - BMO	GFOA FLight	252.92	2543
101-41-1500-52100	New Displayport cords for workstations	BANK OF MONTREAL - BMO	Concrete Pour WTP#1	38.88	2543
101-41-1500-52100	Expansion Mic for Meeting Owl 3.	BANK OF MONTREAL - BMO	Expansion Mic for Meeting Owl 3.	252.04	2543
101-41-1500-52100	Monthly Mailchimp subscription	BANK OF MONTREAL - BMO	Monthly Mailchimp subscription	26.50	2543
101-41-1910-52010	Misc Office Supplies (New Hire and Web C	BANK OF MONTREAL - BMO	Misc Office Supplies (New Hire and Web Cams - Multiple Depts)	442.10	2543
101-41-1910-52010	Office Supplies - Heaters and Organizer	BANK OF MONTREAL - BMO	Office Supplies - Heaters and Organizer	101.86	2543
101-41-1910-53080	Registration for Steve - Training/Networ	BANK OF MONTREAL - BMO	Registration for Steve - Training/Networking	58.00	2543
101-41-1910-53520	Recording - Smokey Oaks	BANK OF MONTREAL - BMO	Recording - Smokey Oaks	57.18	2543
101-41-1910-53520	Recording - Interstate Agreements	BANK OF MONTREAL - BMO	Recording - Smokey Oaks	57.18	2543
101-41-1910-53520	Interstate Agreement	BANK OF MONTREAL - BMO	Recording - Smokey Oaks	57.18	2543
101-42-2100-52100	Safe Monitoring Service at FLA Community	BANK OF MONTREAL - BMO	Safe Monitoring Service at FLA Community School	49.99	2543
101-42-2100-52100	Safe Monitoring Service at FLA High Scho	BANK OF MONTREAL - BMO	Safe Monitoring Service at FLA Community School	49.99	2543
101-42-2100-52100	Safe Monitoring Service for FLA Middle S	BANK OF MONTREAL - BMO	Safe Monitoring Service at FLA Community School	49.99	2543
101-42-2100-52210	Squad #2115 (Monthly Recurring)	BANK OF MONTREAL - BMO	Squad #2115 (Monthly Recurring)	35.75	2543
101-42-2100-52210	Squad #2104 - Recurring Monthly Payment	BANK OF MONTREAL - BMO	Squad #2115 (Monthly Recurring)	35.75	2543
101-42-2100-52210	Squad #2005 - Recurring Monthly Payment	BANK OF MONTREAL - BMO	Squad #2115 (Monthly Recurring)	35.75	2543
101-42-2100-52210	Squad #2504 - Recurring Monthly Payment	BANK OF MONTREAL - BMO	Squad #2115 (Monthly Recurring)	35.75	2543
101-42-2100-52210	Squad #2507 - Recurring Monthly Payment	BANK OF MONTREAL - BMO	Squad #2115 (Monthly Recurring)	35.75	2543
101-42-2100-52210	Squad #2118 - Recurring Monthly Payment	BANK OF MONTREAL - BMO	Squad #2115 (Monthly Recurring)	35.75	2543
101-42-2100-52210	Squad #2011 - Recurring Monthly Payment	BANK OF MONTREAL - BMO	Squad #2115 (Monthly Recurring)	35.75	2543
101-42-2100-52210	Squad #2013 - Recurring Monthly Payment	BANK OF MONTREAL - BMO	Squad #2115 (Monthly Recurring)	35.75	2543
101-42-2100-52210	Squad #2012 - Recurring Monthly Payment	BANK OF MONTREAL - BMO	Squad #2115 (Monthly Recurring)	35.75	2543
101-42-2100-52210	Squad #2208 - Recurring Monthly Payment	BANK OF MONTREAL - BMO	Squad #2115 (Monthly Recurring)	35.75	2543
101-42-2100-52210	Squad #2406- Recurring Monthly Payment	BANK OF MONTREAL - BMO	Squad #2115 (Monthly Recurring)	35.75	2543
101-42-2100-52210	Squad #2319 - Recurring Monthly Payment	BANK OF MONTREAL - BMO	Squad #2115 (Monthly Recurring)	35.75	2543
101-42-2100-52210	Squad #2416 - Recurring Monthly Payment	BANK OF MONTREAL - BMO	Squad #2115 (Monthly Recurring)	35.75	2543

101-42-2100-53060	Check In - Lafferty, Carpenter, Rude	BANK OF MONTREAL - BMO	Check In - Lafferty, Carpenter, Rude	420.00	2543
101-42-2100-53080	2025 IACP Conference - Breakfast/Lunch -	BANK OF MONTREAL - BMO	2025 IACP Conference - Breakfast/Lunch - R. Peterson	24.91	2543
101-42-2100-53080	2025 IACP Conference - Breakfast/Lunch -	BANK OF MONTREAL - BMO	2025 IACP Conference - Breakfast/Lunch - R. Peterson	20.91	2543
101-42-2100-53080	2025 IACP Conference - Breakfast/Lunch -	BANK OF MONTREAL - BMO	2025 IACP Conference - Breakfast/Lunch - R. Peterson	28.93	2543
101-42-2100-53080	2025 IACP Conference - Hotel - L. Hanegr	BANK OF MONTREAL - BMO	2025 IACP Conference - Hotel - R. Peterson	1,788.34	2543
101-42-2100-53080	2025 IACP Conference - Hotel - R. Peters	BANK OF MONTREAL - BMO	2025 IACP Conference - Hotel - R. Peterson	1,794.34	2543
101-42-2100-53080	MSP Airport Parking - Squad #2401 - R. P	BANK OF MONTREAL - BMO	MSP Airport Parking - Squad #2401 - R. Peterson	195.35	2543
101-42-2100-53080	2025 IACP Conference - Squad #2002 - L.	BANK OF MONTREAL - BMO	MSP Airport Parking - Squad #2401 - R. Peterson	149.76	2543
101-42-2100-53080	Training	BANK OF MONTREAL - BMO	Training	90.00	2543
101-42-2100-53080	Registration cost for FBI LEEDA class	BANK OF MONTREAL - BMO	Registration cost for FBI LEEDA class	795.00	2543
101-42-2100-53080	Balance of hotel expense for MAPET Confe	BANK OF MONTREAL - BMO	Balance of hotel expense for MAPET Conference	181.46	2543
101-42-2100-53080	ICAC training conference scheduled away	BANK OF MONTREAL - BMO	ICAC training conference scheduled away from home.	204.02	2543
101-42-2100-53080	2025 TZD Conference Registration - T. Co	BANK OF MONTREAL - BMO	2025 TZD Conference Registration - T. Coulter	150.00	2543
101-42-2100-53080	MN-LEAP membership application fee	BANK OF MONTREAL - BMO	MN-LEAP membership application fee	50.00	2543
101-42-2100-53080	MN BCA 2025 - Internet Crimes Against Ch	BANK OF MONTREAL - BMO	MN BCA 2025 - Internet Crimes Against Children and Human Trafficking - N. Olstad	300.00	2543
101-42-2100-53080	Fall Range Training	BANK OF MONTREAL - BMO	Fall Range Training	720.00	2543
101-42-2100-53080	Flight Protection Plan for ICAP Conferen	BANK OF MONTREAL - BMO	Flight Protection Plan for ICAP Conference-A.Newman & L.Hanegraaf	22.36	2543
101-42-2100-54040	Bio-hazard squad clean up-FL25007131	BANK OF MONTREAL - BMO	Bio-hazard squad clean up-FL25007131	150.00	2543
101-42-2100-54040	BIO-Hazard squad clean up. FL25008228	BANK OF MONTREAL - BMO	Bio-hazard squad clean up-FL25007131	150.00	2543
101-42-2125-52010	Organization bins for Safety Camp invent	BANK OF MONTREAL - BMO	Organization bins for Safety Camp inventory storage	122.94	2543
101-42-2125-53520	FL Safety Camp - Domain Name 10/11/2025-	BANK OF MONTREAL - BMO	FL Safety Camp - Domain Name 10/11/2025-11/10/2025	10.64	2543
101-42-2200-52100	UPS Charge to ship E3 truck title.	BANK OF MONTREAL - BMO	4th Quarter Fluoride sample mailed UPS	16.30	2543
101-42-2200-52100	Fuel Card Holders for the vehicles.	BANK OF MONTREAL - BMO	Fuel Card Holders for the vehicles.	55.93	2543
101-42-2200-52100	3 ring binder pouched for apparatus. -	BANK OF MONTREAL - BMO	3 ring binder pouched for apparatus. - Hold insurance cards.	27.96	2543
101-42-2200-52100	Replacement battery for AED located in R	BANK OF MONTREAL - BMO	Replacement battery for AED located in R1 Med Bag.	215.94	2543
101-42-2200-52100	Medical Mask for Pets - EMS.	BANK OF MONTREAL - BMO	Medical Mask for Pets - EMS.	80.99	2543
101-42-2200-52100	Debris bags	BANK OF MONTREAL - BMO	Debris bags	160.65	2543
101-42-2200-52100	Printer Cartridges - Radio Room Printer.	BANK OF MONTREAL - BMO	Printer Cartridges - Radio Room Printer.	303.58	2543
101-42-2200-52400	Replacement Halligan Tool for E3.	BANK OF MONTREAL - BMO	Replacement Halligan Tool for E3.	190.33	2543
101-42-2200-52400	Fire Axe to replace lost/damaged fire ax	BANK OF MONTREAL - BMO	Fire Axe to replace lost/damaged fire axe.	95.99	2543
101-42-2200-52400	Halligan bar to replace lost/damaged hal	BANK OF MONTREAL - BMO	Halligan bar to replace lost/damaged halligan bar.	369.53	2543
101-42-2200-52420	Helmet Flashlights.	BANK OF MONTREAL - BMO	Helmet Flashlights.	559.96	2543
101-42-2200-52420	Medical Pouches.	BANK OF MONTREAL - BMO	Medical Pouches.	142.39	2543
101-42-2200-53080	Breakfast expense - IACP Conference.	BANK OF MONTREAL - BMO	2025 IACP Conference - Breakfast/Lunch - R. Peterson	27.28	2543
101-42-2200-53080	Hotel Room for IACP	BANK OF MONTREAL - BMO	2025 IACP Conference - Hotel - R. Peterson	1,805.02	2543
101-42-2200-53080	Taxi service from Denver airport to hote	BANK OF MONTREAL - BMO	Taxi service from Denver airport to hotel. Hanegraaf and Newman IACP Conference.	115.00	2543
101-42-2200-53080	Flight Protection Plan for ICAP Conferen	BANK OF MONTREAL - BMO	Flight Protection Plan for ICAP Conference-A.Newman & L.Hanegraaf	22.36	2543
101-42-2200-53090	LACRM for I-Pads.	BANK OF MONTREAL - BMO	LACRM for I-Pads.	90.00	2543
101-43-3100-52100	Bollard for trail	BANK OF MONTREAL - BMO	Bollard for trail	269.00	2543
101-43-3100-54040	Vehicle Damage Repair - Insurance Claim	BANK OF MONTREAL - BMO	Vehicle Damage Repair - Insurance Claim	9,433.53	2543
101-43-3180-52100	Shop supplies	BANK OF MONTREAL - BMO	Shop supplies	501.99	2543
101-45-5120-54370	Mounting Hardware for Park Sign	BANK OF MONTREAL - BMO	Mounting Hardware for Park Sign	75.83	2543
101-45-5120-54380	Roasting sticks and necklaces for Hometo	BANK OF MONTREAL - BMO	Roasting sticks and necklaces for Hometown Holiday.	206.96	2543
101-45-5120-54380	Microphone rental for Beltz Park Grand R	BANK OF MONTREAL - BMO	Microphone rental for Beltz Park Grand Reopening	25.00	2543
101-45-5200-52100	bleacher clips	BANK OF MONTREAL - BMO	bleacher clips	76.42	2543
101-45-5200-53080	K. Werner - Turf Training	BANK OF MONTREAL - BMO	K. Werner - Turf Training	45.00	2543
101-45-5200-54030	Swing mats for Beltz	BANK OF MONTREAL - BMO	Swing mats for Beltz	1,774.98	2543
101-46-6625-54370	Expenses for Senior Center	BANK OF MONTREAL - BMO	Expenses for Senior Center	18.78	2543
101-46-6625-54370	Food for Senior Center	BANK OF MONTREAL - BMO	Food for Senior Center	65.76	2543
212-46-1920-54370	Gala Attendance - Mark and Abbi	BANK OF MONTREAL - BMO	Gala Attendance - Mark and Abbi	190.00	2543
631-49-9420-52100	Concrete Pour WTP#1	BANK OF MONTREAL - BMO	Concrete Pour WTP#1	195.50	2543
631-49-9420-52100	Fuses for WTP#4 Brine pumps	BANK OF MONTREAL - BMO	Fuses for WTP#4 Brine pumps	81.50	2543
631-49-9420-52100	Phone Case	BANK OF MONTREAL - BMO	Phone Case	19.33	2543
631-49-9420-52100	CABLE FOR METER READING	BANK OF MONTREAL - BMO	CABLE FOR METER READING	17.32	2543
631-49-9440-53220	Postage for samples	BANK OF MONTREAL - BMO	Postage for samples	17.51	2543
631-49-9440-53220	4th Quarter Fluoride sample mailed UPS	BANK OF MONTREAL - BMO	4th Quarter Fluoride sample mailed UPS	11.50	2543
631-49-9440-53220	THM water sample shipping.	BANK OF MONTREAL - BMO	4th Quarter Fluoride sample mailed UPS	46.25	2543

Total For Check 2543

28,775.34

Check 2544					
101-00-0000-21800	RETIREE HEALTH INS PAYABLE	SOURCEWELL	RETIREE HEALTH INSURANCE-DECEMBER 22025	3,920.00	2544
101-42-2100-51310	HEALTH INSURANCE	SOURCEWELL	RETIREE HEALTH INSURANCE-DECEMBER 22025	<u>3,997.00</u>	2544
		Total For Check 2544		<u>7,917.00</u>	
Check 2545					
101-00-0000-21714	FSA MEDICAL DED PAYABLE	BENEFIT EXTRAS INC	SETTLE PURCHASE	<u>897.07</u>	2545
		Total For Check 2545		897.07	
Check 2546					
101-00-0000-21714	FSA MEDICAL DED PAYABLE	BENEFIT EXTRAS INC	CLAIM REIMBURSEMENT	<u>5,770.59</u>	2546
		Total For Check 2546		5,770.59	
Check 2547					
101-00-0000-22440	SALES TAX PAYABLE	SALES TAX MN DEPT REVENUE EFT	NOVEMBER 2025 SALES TAX	66.00	2547
631-00-0000-22440	SALES TAX PAYABLE	SALES TAX MN DEPT REVENUE EFT	NOVEMBER 2025 SALES TAX	<u>59.00</u>	2547
		Total For Check 2547		125.00	
Check 2548					
101-00-0000-21709	LIFE INSURANCE PAYABLE	THE HARTFORD	DECEMBER 2025 COBRA LIFE INSURANCE	<u>59.40</u>	2548
		Total For Check 2548		59.40	
Check 2549					
101-00-0000-21714	FSA MEDICAL DED PAYABLE	BENEFIT EXTRAS INC	CLAIM REIMBURSEMENT	<u>1,896.00</u>	2549
		Total For Check 2549		1,896.00	
Check 2550					
101-00-0000-21713	DENTAL INSURANCE PAYABLE	HEALTH PARTNERS	HPAI SELF INSURED CLAIMS 15657 - DECEMBER 2025	<u>1,540.33</u>	2550
		Total For Check 2550		1,540.33	
Check 2551					
101-41-1400-54370	POSTIVE PAY MONTHLY FEE-NOVEMBER	MIDWESTONE BANK	POSITIVE PAY MONTHLY FEE-NOVEMBER	<u>58.90</u>	2551
		Total For Check 2551		58.90	
Check 2552					
101-45-5200-53810	ELECTRIC UTILITIES	XCEL ENERGY	51-5193669-9 ~ AUTO PROTECTIVE LIGHT	<u>10.30</u>	2552
		Total For Check 2552		10.30	
Check 2553					
101-45-5130-53810	ELECTRIC UTILITIES	XCEL ENERGY	51-4770834-3 ~ 21640 HARROW AVE N	423.62	2553
632-49-9450-53810	ELECTRIC UTILITIES	XCEL ENERGY	51-0239658-9 ~ LIFT STATIONS	<u>208.57</u>	2553
		Total For Check 2553		632.19	
Check 2554					
101-43-3160-53810	ELECTRIC UTILITIES	XCEL ENERGY	51-9753120-9 ~ 1601 11TH AVE SW-BRIDGE	70.50	2554
101-45-5200-53810	ELECTRIC UTILITIES	XCEL ENERGY	51-5193669-9 ~ 777 4TH ST SW RINK & WARMING HOUSE	85.25	2554
631-49-9420-53810	ELECTRIC UTILITIES	XCEL ENERGY	51-5193673-5 ~ 1850 8TH ST SE - WTP	353.70	2554
632-49-9450-53810	ELECTRIC UTILITIES	XCEL ENERGY	51-4372874-7 ~ 406 15TH ST SW-LIFT	360.33	2554
632-49-9450-53810	ELECTRIC UTILITIES	XCEL ENERGY	51-0014133727-6 ~ 23845 GRANADA AVE N LIFT STATION	26.30	2554
632-49-9450-53810	ELECTRIC UTILITIES	XCEL ENERGY	51-0014644299-0 ~ 9597 NORTH SHORE TRL N UNIT-LIFT STATION	<u>32.26</u>	2554
		Total For Check 2554		928.34	
Check 2555					
101-00-0000-21714	FSA MEDICAL DED PAYABLE	BENEFIT EXTRAS INC	CLAIM REIMBURSEMENT	<u>108.67</u>	2555
		Total For Check 2555		108.67	

Check 2556					
101-00-0000-21713	DENTAL INSURANCE PAYABLE	HEALTH PARTNERS	HPAI SELF INSURED CLAIMS 15657 - DECEMBER 2025	<u>2,885.57</u>	2556
		Total For Check 2556		<u>2,885.57</u>	
Check 2558					
101-43-3160-53810	ELECTRIC UTILITIES	XCEL ENERGY	51-5193663-3 ~ TRAFFIC SIGNALS	203.65	2558
632-49-9450-53810	ELECTRIC UTILITIES	XCEL ENERGY	51-5193674-6 ~ LIFT STATIONS	276.24	2558
632-49-9450-53810	ELECTRIC UTILITIES	XCEL ENERGY	51-5193672-4 ~ LIFT STATIONS	<u>3,008.74</u>	2558
		Total For Check 2558		<u>3,488.63</u>	
Check 2559					
632-49-9450-53810	ELECTRIC UTILITIES	XCEL ENERGY	51-5193672-4 ~ LIFT STATIONS	<u>343.72</u>	2559
		Total For Check 2559		<u>343.72</u>	
		Fund Totals:			
			Fund 101 GENERAL FUND	393,912.72	
			Fund 203 PARK DEDICATION FUND	13,292.30	
			Fund 205 SURFACE WATER MANAGEMENT FUND	45,714.79	
			Fund 211 CAPITAL IMPROVEMENT FUND	139,255.09	
			Fund 212 ECONOMIC DEVELOPMENT FUND	17,171.25	
			Fund 323 DEBT SERVICE EDA REFUNDING	186,200.00	
			Fund 325 DEBT SERVICE YMCA	521,906.25	
			Fund 326 DEBT SERVICE PAVEMENT FUND	475.00	
			Fund 328 2025 G.O. STREET RECON BONDS	2,435,302.78	
			Fund 401 CAPITAL EQUIPMENT FUND	106,278.88	
			Fund 631 WATER FUND	74,290.09	
			Fund 632 SEWER FUND	517,828.27	
			Fund 800 PROJECT DEVELOPMENT FUND	60,055.00	
				<u><u>4,511,682.42</u></u>	

01/08/2026

INVOICE GL DISTRIBUTION REPORT FOR FOREST LAKE
 EXP CHECK RUN DATES 12/22/2025 - 01/12/2026
 BOTH JOURNALIZED AND UNJOURNALIZED
 PAID

GL Number	Invoice Line Desc	Vendor	Invoice Description	Amount	Check #
Check 118628 250-43-9810-53050-047457-023	ENGINEERING CHARGES	BOLTON & MENK INC	RUNWAY 13/31 AND TAXIWAY A	<u>2,500.00</u>	118628
		Total For Check 118628		<u>2,500.00</u>	
Check 118642 250-43-9810-53040	LEGAL SERVICES	ECKBERG LAMMERS P.C.	AIRPORT	<u>57.00</u>	118642
		Total For Check 118642		<u>57.00</u>	
Check 118793 250-43-9810-53070	PROFESSIONAL SERVICES	TIMESAVER OFF SITE SECRETARIAL INC	12/03/2025 - AIRPORT COMMISSION MEETING 1 HOURS	<u>172.00</u>	118793
		Total For Check 118793		<u>172.00</u>	
Check 2539 250-43-9810-53810	ELECTRIC UTILITIES	XCEL ENERGY	51-9849041-6 ~ 20500 FOREST RD N U#1-AIRPORT	<u>32.10</u>	2539
		Total For Check 2539		<u>32.10</u>	
Check 2552 250-43-9810-53810	ELECTRIC UTILITIES	XCEL ENERGY	51-5193679-1 ~ AIRPORT	<u>23.91</u>	2552
		Total For Check 2552		<u>23.91</u>	
Check 2557 250-43-9810-53210-047457-023	TELEPHONE	MIDCONTINENT COMMUNICATIONS	AIRPORT PHONE DECEMBER 2025	<u>175.39</u>	2557
		Total For Check 2557		<u>175.39</u>	
		Fund Totals:	Fund 250 AIRPORT FUND	<u>2,960.40</u>	
				<u>2,960.40</u>	



City Council

Regular Meeting

~ Minutes ~

1408 Lake Street South
Forest Lake, MN 55025
www.ci.forest-lake.mn.us

Monday, November 10, 2025

6:00 PM

City Center - Council Chamber

[City of Forest Lake - Livestream and Recorded Meetings](#)

1. Call to Order

2. Roll Call

Attendee Name	Title	Status	Arrived
Blake Roberts	Mayor	Present	
Jeff Larson	Councilmember	Present	
Hanna Valento	Councilmember	Present	
Leif Erickson	Councilmember	Present	
Kevin Miller	Councilmember	Present	

3. Pledge of Allegiance

4. Approve the Agenda (Action)

Motion: Mayor Roberts made a Motion to Approve the Agenda, adding 8.e., 55 4th Avenue NW Administrative Citation Settlement Agreement.

Motion seconded by Councilmember Erickson. Motion carried 5-0.

5. Awards and Presentations

a) Review of County Road 50 & US Highway 61 Intersection Study – Washington County Highway Department Staff

Washington County Commissioner Fran Miron reviewed the County Road 50 & US Highway 51 Intersection Study. He introduced the project manager.

Washington County Project Manager Ryan Hoefs provided an overview of the current issues at the intersection and agency partners. He explained the outside funding available for the project and the project goals. He summarized the discussion at the first open house on July 9, 2025. He reviewed the traffic signal alternatives, including a roundabout. He summarized the discussion and noted that most residents preferred the roundabout alternative at the second open house on September 17, 2025.

6. Open Forum – Citizen Petitions, Requests, and Concerns

The Open Forum is available for residents to express personal opinions for any item of business. Please limit your comments to three (3) minutes.

Comments:

None.



City Council

Regular Meeting

~ Minutes ~

1408 Lake Street South
Forest Lake, MN 55025
www.ci.forest-lake.mn.us

Monday, November 10, 2025

6:00 PM

City Center - Council Chamber

7. Consent Agenda Considerations (Action Items)

Mayor Roberts requested to remove item 7.n. from the Consent Agenda.

- a. City Invoices
 - i) General Invoices
 - ii) Airport Invoices
- b. October 20, 2025 Council Workshop Minutes
- c. October 20, 2025 Council Special Meeting Minutes
- d. October 25, 2025 Council Special Workshop Meeting Minutes
- e. 2026 Funding Support Agreement between CFL and CLA
- f. Development Agreement Amendment – Forest Hills Preserve
- g. Flexible Spending Account Plan Amendment
- h. Police Officer Hiring Recommendation
- i. Gambling Permit Approval
- j. Fee Waiver Request: Rotary Club
- k. Maintenance & Operational Grants – FL Airport – MNDOT
- l. 891 19th Street SE Pervious Surface Agreement
- m. Hidden Creek Phase 3 Utility & Street Improvements – Letter of Credit Reduction Request No. 1
- ~~n. Resolution 11-10-25-03 Accepting Donations – Senior Center~~
- o. 2026 Funding Support Agreement with the Clear Lake Association

Motion: Mayor Roberts made a Motion to Approve the Consent Agenda Items 7.a. through 7.m. and 7.o.

Motion seconded by Councilmember Valento. Motion carried 5-0.

n. Resolution 11-10-25-03 Accepting Donations – Senior Center

Mayor Roberts reviewed the generous donation from Lakes Area Asphalt and the Community Co. Church, who helped complete seal coat and paint striping work at the Forest Lake Senior Center parking lot.

Motion: Mayor Roberts made a Motion to Approve Item 7.n., Resolution 11-10-25-03 Accepting Donations – Senior Center.

Motion seconded by Councilmember Erickson. Motion carried 5-0.

8. Regular Agenda (Action Items)

a) Decertification of TIF Districts (Cherrywood and Centennial) – Elle Larkin

Finance Director Larkin provided a summary of how tax increment financing works and the key requirements. She explained the tax increment financing cash flow. She noted that they were looking to decertify specific tax increment financing districts and the increased tax capacity available.



City Council

Regular Meeting

~ Minutes ~

1408 Lake Street South
Forest Lake, MN 55025
www.ci.forest-lake.mn.us

Monday, November 10, 2025

6:00 PM

City Center - Council Chamber

Motion: Councilmember Erickson made a Motion to Adopt Resolution 11-10-25-01 Decertification, and transfer of TIF Funds to pay the interfund loan, thus increasing the City's Tax capacity by an estimated \$217,729 for Pay 2026.

Motion seconded by Councilmember Larson. Motion carried 5-0.

b) Franchise Fee Increases – Elle Larkin

1) Ordinance 760 – Gas Franchise Fee

2) Ordinance 761 – Electric Franchise Fee

3) Resolution 11-10-25-02 – Summary Publication

City Administrator Statz noted that the City adopted franchise fees in 2013 on gas and electricity, which were used to support the reconstruction of roads. The rates have not increased since 2013. He said that they had to complete the increase by 25 25-cent increases. He noted that this increase could decrease the levy if desired.

Motion: Councilmember Valento made a Motion to adopt Ordinances 760 and 761, allowing adjustment to the City's gas and electric franchise fees.

Motion seconded by Councilmember Miller. Motion carried 5-0.

Motion: Councilmember Valento made a Motion to Adopt Resolution 11-10-25-02, authorizing summary publication of 760 and 761.

Motion seconded by Councilmember Miller. Motion carried 5-0.

c) Fee Schedule Update – Elle Larkin

1) Ordinance 762

Finance Director Larkin noted that when a fee schedule is updated, the ordinance associated needs to be updated. The fee schedule included the final development plan review fee. Community Development Director Wittman added that the City Code required that the City Engineer develop all final plans and specifications for a development project, but the City Administrator could allow another City Engineer to complete this task. Director Wittman noted that this fee schedule would allow for another engineer to complete the plans and the City Engineer to review the plans; further that this would be an escrow system to cover the costs. She explained that they could get a final plat within the time frame, so they wanted to see if they could cover the costs of those final plans and specifications.

Motion: Councilmember Erickson made a Motion to Adopt Ordinance 762, An Ordinance Amending City Code Chapter 35, Fees and Service Charges.

Motion seconded by Councilmember Miller. Motion carried 5-0.

d) Eureka Ave Improvements: Bid Results & Award Recommendation – Ryan Goodman

City Engineer Goodman reviewed the five bids received for the Eureka Avenue Improvements project. He noted that the above bids did not include the costs or scope of work for potential project street lighting and that the staff was waiting for federal funding review for the DNR



City Council

Regular Meeting

~ Minutes ~

1408 Lake Street South
Forest Lake, MN 55025
www.ci.forest-lake.mn.us

Monday, November 10, 2025

6:00 PM

City Center - Council Chamber

Roadway Easement required to reconstruct a portion of Eureka Avenue. He stated that the staff recommends the City award the contract to Forest Lake Contracting, Inc. to perform work included in the base bid, alternate three, and alternate four with specific conditions.

Motion: Councilmember Erickson made a Motion to Award the Contract to Forest Lake Contracting Inc. to perform the work included in the Base Bid, Alternate 3, and Alternate 4 in the amount of \$3,387,743.50, with the conditions as listed in the staff report.

Motion seconded by Councilmember Valento. Motion carried 5-0.

- e) **55 4th Avenue NW Administrative Citation Settlement Agreement – Abbi Wittman**
Community Development Director Wittman summarized the settlement agreement with the property owner at 55 4th Avenue Northwest. She reviewed the administrative citation agreement process and noted that the landowner had unsheltered storage and an improper vehicle.

Motion: Councilmember Erickson made a Motion to Approve the settlement agreement with Samara Montoya, property owner of 55 4th Avenue NW, with minor modifications made by the City Attorney. Motion seconded by Councilmember Valento. Motion carried 5-0.

9. Discussion

None.

10. Staff Updates

Finance Director Larkin said that they would be seeking final budget recommendations at the next workshop prior to the Truth and Taxation meeting.

City Engineer Goodman noted that Highway 97 was fun to drive.

Community Development Director Wittman noted that the new building official was starting on Wednesday morning.

Fire Chief Newman noted that they sold Engine 2. He noted they were selling additional vehicles.

Chief of Police Peterson reviewed the new officers at the Forest Lake Police Department.

City Administrator Statz thanked the bargaining units for the great discussions.

11. Mayor and City Council Updates



City Council

Regular Meeting

~ Minutes ~

1408 Lake Street South
Forest Lake, MN 55025
www.ci.forest-lake.mn.us

Monday, November 10, 2025

6:00 PM

City Center - Council Chamber

Councilmember Miller hoped that residents would appreciate the roads that were in good condition during construction season.

Mayor Roberts said that the Chamber had the Gala Awards, and the City won an award for Arts in the Park.

12. Adjourn

Motion: Councilmember Erickson made a Motion to Adjourn the Regularly Scheduled Council Meeting at 7:07 p.m.

Motion seconded by Councilmember Valento. Motion carried 5-0.



City Council

Workshop

~ Minutes ~

1408 Lake Street South
Forest Lake, MN 55025
www.ci.forest-lake.mn.us

Monday, November 17, 2025

6:00 PM

City Center - Council Chamber

[City of Forest Lake - Livestream and Recorded Meetings](#)

1. Call to Order

2. Roll Call

Attendee Name	Title	Status	Arrived
Blake Roberts	Mayor	Present	
Jeff Larson	Councilmember	Present	
Hanna Valento	Councilmember	Present	
Leif Erickson	Councilmember	Present	
Kevin Miller	Councilmember	Present	

3. Pledge of Allegiance

4. Open Forum – Citizen Petitions, Requests, and Concerns

The Open Forum is available for residents to express personal opinions for any item of business. Please limit your comments to three (3) minutes.

Comments:

Don Shipp, Forest Lake Hangar Owner, reviewed his previous discussion with the Airport Commission, which requested that hangar owners help cover the pavement costs. He stated that the airport was zoned improperly and that the hangar owners and MnDOT Aeronautics paid a large portion of the fees. The Airport Commission previously voted in 2016 to require hangar owners to pay \$ 8,600 for the pavement. He said that the City Council took the action and put it into a fee schedule. He noted that the hangar owners pay their fair share, and the City was violating the contract. He said his portion was paid by a City Council member, Sam Husnick construction, which should be viewed as a bribe. He expressed motivation to encourage the City to do the right thing.

Doug Shipp, Resident, said he was here to advocate for the hangar owners who paid the charges, since there is an imbalance that needs to be corrected. He stated he did not see a deadline to fix the imbalance. He said that there was an imbalance of people who paid and were not refunded. He said there was discrimination between private hangar operators and commercial hangar operators. He said if they allow people to take up residence in their hangars, this would be considered an imbalance.

5. Strategic Plan – Mark Statz

City Administrator Statz said he wanted to recap the Saturday strategic plan meeting. He reviewed the strategic priorities discussed at the meeting and provided additional context for the different priorities.



City Council

Workshop

~ Minutes ~

1408 Lake Street South
Forest Lake, MN 55025
www.ci.forest-lake.mn.us

Monday, November 17, 2025

6:00 PM

City Center - Council Chamber

Councilmembers provided comments indicating satisfaction with the first two priorities as determined at the meeting and added focus on organizational stability and recreation would be key.

Mayor Roberts suggested addition of up to two strategic priorities and suggested that each department determine one or two strategic initiatives to make sure that the City and City Council were all going in the same direction.

City Administrator Statz said that the department heads could bring strategic initiatives to the City Council, but the City Council would also provide themes to the department heads. He stated they could discuss more information at the department head meeting.

6. Comp Plan – Abbi Wittman

Community Development Director Wittman presented on the Imagine 2050, the Metropolitan Council's regional development guide process. She stated that the City could offer amendment suggestions and she reviewed the system statement process for high-level education and to see if there were any amendments they would like to make. She discussed the split designation and added that the City could still write a letter to express concern about the required density and housing growth. Director Wittman added that Forest Lake might not be growing as quickly as the Metropolitan Council once thought. She asked if the City Council would like to make a request to the Metropolitan Council about the community designation and how they are allowing them to calculate the densities, noting that the Metropolitan Council has been known to deny sewer services to those who do not meet the densities.

Council held discussion on Community Development Director Wittman' presentation and provided direction for staff to draft a letter and a formal resolution to the Met Council for the City Council's consideration.

7. Budget – Elle Larkin

Finance Director Larkin reviewed the previous budget work and noted that they had increased franchise fees, police State-aid, and brought back overtime. She said that the adjustments would bring the levy to 9.25 percent, so the City Council would need to provide direction if they were comfortable with the number or if they would like to bring the levy down to 8.9 percent. She asked the City Council for feedback about the target number. City Administrator Statz added that 8.9 percent would eliminate the future sergeant position from the budget.

Council discussed the public safety positions and suggested holding off on the sergeant position for 2026. Specifically, Council provided direction to continue to move forward with the officer and patrol positions, but not the sergeant position.

Further discussion was held on the proposed Public Works Maintenance Operator position to be slated into the Parks Maintenance division. Public Works Director Dave Adams provided background on increased field maintenance.



City Council

Workshop

~ Minutes ~

1408 Lake Street South
Forest Lake, MN 55025
www.ci.forest-lake.mn.us

Monday, November 17, 2025

6:00 PM

City Center - Council Chamber

Council also discussed reducing capital purchases/capital equipment. Administrator Statz noted that Council could pull back capital purchases, such as only purchasing nine trucks rather than ten trucks in ten years.

Councilmember Erickson said that the fund balance over the last year was in the capital fund. City Administrator Statz also provided clarification related to excess fund balance and directing that excess to the capital fund; he added the City is under budget this year, so the amount would go into the capital fund.

Further discussion was held on various fund balances and reducing those fund balances to help the future levy projections.

Councilmember Miller asked how the sale of property by the City impacted them. City Administrator Statz answered that it would not change the expenses, and next year the levy would increase because they started at a lower point.

Mayor Roberts asked Council if they were comfortable with current proposed levy number. The consensus of Council was to further reduce the levy. City Administrator Statz said they could revise it so they could see the 8.9 percent.

8. Adjourn

Mayor Roberts adjourned the meeting at 7:43 p.m.



City Council

Regular Meeting

~ Minutes ~

1408 Lake Street South
Forest Lake, MN 55025
www.ci.forest-lake.mn.us

Monday, November 24, 2025

6:00 PM

City Center - Council Chamber

[City of Forest Lake - Livestream and Recorded Meetings](#)

1. Call to Order

2. Roll Call

Attendee Name	Title	Status	Arrived
Blake Roberts	Mayor	Present	
Jeff Larson	Councilmember	Present	
Hanna Valento	Councilmember	Present	
Leif Erickson	Councilmember	Present	
Kevin Miller	Councilmember	Present	

3. Pledge of Allegiance

4. Approve the Agenda (Action)

Motion: Councilmember Erickson made a Motion to Approve the Agenda as presented. Motion seconded by Councilmember Valento. Motion carried 5-0.

5. Awards and Presentation

- a. None

6. Open Forum – Citizen Petitions, Requests, and Concerns

The Open Forum is available for residents to express personal opinions for any item of business. Please limit your comments to three (3) minutes.

Comments: None.

7. Consent Agenda Considerations (Action Items)

Councilmember Miller requested to remove item 7.a.i. and 7.g. from the Consent Agenda.

- a. ~~City Invoices~~
 - i. ~~General Invoices~~
 - ii. Airport Invoices
- b. Approval of Property Transfer – 368 Lake Street South (Ross Orthodontics Building)
- c. North Shore Trail and 2025 Street Pavement Maintenance Project – Contractor’s Request
- d. 2025 South Water Tower Rehabilitation – Contractor’s Request for Payment No. 2 and FINAL
- e. Veteran’s Memorial Lake Side Park – Contractor’s Request for Payment No. 2
- f. Arts in the Park Agreement for Professional Services
- g. ~~Castlewood Management Agreement~~
- h. Hometown Holiday Entertainment Contract



City Council

Regular Meeting

~ Minutes ~

1408 Lake Street South
Forest Lake, MN 55025
www.ci.forest-lake.mn.us

Monday, November 24, 2025

6:00 PM

City Center - Council Chamber

- i. Arts in the Park Policy
- j. Athletic Facilities User Classification Policy
- k. Veterans Memorial Maintenance Agreement
- l. Resolution 11-24-25-01 Declaring Surplus Property – Public Works
- m. Geotechnical & Environmental Investigation Proposals – Future Public Works Site
- n. First Amendment to Agreement – RJ’s Property Maintenance, Inc.
- o. Temporary Hiring Recommendations
- p. Deputy City Clerk Hiring Recommendation
- q. Safe Assure Safety Training Contract
- r. Gambling Permit Application
- s. Temporary On-Sale Liquor Permit Application
- t. Resolution 11-24-25-05 Setting 2026 Non-Union Wage Schedule
- u. Resolution 11-24-25-03 2026 BCA JPA

Motion: Councilmember Miller made a Motion to Approve the Consent Agenda Items 7.a.ii. through 7.f. and 7.h. through 7.u.

Motion seconded by Councilmember Valento. Motion carried 5-0.

a. City Invoices

i. General Invoices

Councilmember Miller noted the lease payment to St. Peter’s Catholic Church for parking at Beltz Park and inquired why the City paid that high cost for parking when there was plenty of street parking. He suggested that the Parks and Recreation Commission review the lease and costs. Staff provided background on the agreement, which was initiated in 2024 during a time where a Parks and Recreation Commission was not seated.

Motion: Councilmember Miller made a Motion to Approve Item 7.a.i., General Invoices, with the provision that the Parks and Recreation Commission review the lease with St. Peter’s Catholic Church. Motion seconded by Councilmember Valento. Motion carried 5-0.

g. Castlewood Management Agreement

Councilmember Miller requested additional background information about the golf course management agreement.

Public Works Director Adams reviewed the agreement and noted that the contract with Foursome Golf Management provides that the first \$50,000 from golf course operations goes to the management company; after that, Foresome Golf Management and the City split profits from the golf course. He stated that it is one of the only Parks and Recreation options that generates revenue for the City. Director Adams also clarified details related to maintenance expenses and CIP projects scheduled for the golf course in future years.



City Council

Regular Meeting

~ Minutes ~

1408 Lake Street South
Forest Lake, MN 55025
www.ci.forest-lake.mn.us

Monday, November 24, 2025

6:00 PM

City Center - Council Chamber

Motion: Councilmember Erickson made a Motion to Approve Item 7.G., Castlewood Management Agreement.

Motion seconded by Councilmember Miller. Motion carried 4-0-1 (?? abstained).

8. Regular Agenda (Action Items)

a) Median Refresh Project Phase II Professional Services Approval – Dave Adams

Public Works Director Adams reviewed the previous median improvement work completed by Midwest Wetland Improvements LLC over the past couple of years and noted that they would like to transition to phase two in 2026. He summarized the bid package for the Phase II Project. He also confirmed that the addition of concrete to the medians was to increase safety for staff during maintenance and that that they were also redoing the irrigation, planting new plantings.

Motion: Councilmember Larson made a Motion to Approve Professional Services with MWI for the Median Refresh Project Phase II Project for \$39,296.

Here. Motion seconded by Councilmember Erickson. Motion carried 5-0.

b) Forest Lake Cannabis Interim Use Permit – Abbi Wittman

Mayor Roberts excused himself from the meeting for this agenda item, and Acting Mayor Valento took on the item as meeting chair.

Community Development Director Wittman presented the interim use permit for Forest Lake Cannabis located at 1467 Lake Street South, Suite 102. She stated that an interim use permit was being used, as the City believed that there could be changes at the State level, so the City wanted to have flexibility. She summarized the City department reviews, mitigation requirements, and buffer requirements. She reviewed the findings and considerations for the interim use permit. Director Wittman discussed the potential of bringing an ordinance amendment to remedy some zoning concerns that have presented due to conflicting licensing types at the state level versus uses at the City level. She stated that they would have time to bring an ordinance amendment to the Planning Commission if desired, but if there are tweaks at the Planning Commission level, there might be difficulties in meeting IUP application timelines.

Councilmember Erickson said that the employee-only restrooms had to be open to the public. He asked how that would be completed. Community Development Director Wittman answered that this information had not been clarified at the time.

Councilmember Miller asked if micro-businesses were just for cannabis or included microbreweries. He asked if this was the last license they could issue based on limitations. Community Development Director Wittman said that this would be the third interim use permit, but they limited the retail registration. She stated they could reconsider the policy to not allow for more interim use permits than legal registrations. She said that the City could take in many interim use permits, but none of them may materialize in an actual registration. She did not



City Council

Regular Meeting

~ Minutes ~

1408 Lake Street South
Forest Lake, MN 55025
www.ci.forest-lake.mn.us

Monday, November 24, 2025

6:00 PM

City Center - Council Chamber

know if there was a better way to complete this task from a zoning perspective.

City Attorney Johnson said that someone could apply for an interim use permit, even if there were no more registrations. She stated that they could do a code amendment tying the interim use permits to the registrations. She said that if it seemed like there needed to be more teeth in the code, they could discuss options.

Councilmember Miller expressed concerns about the buffer with the residential area and Councilmember Larson said the Planning Commission shared those concerns. He added that the Planning Commission also had concerns about the availability of parking spaces. Community Development Director Wittman said that zoning was intended to separate land uses. She said that this type of retail was allowed wherever retail was allowed. She said that the City Council could discuss whether it was appropriate.

Councilmember Miller said he would like to consider making a motion to table this option to get the ordinance and other information in better order before approval.

Jamie White, 5054 93rd Avenue North, Brooklyn Park, read a prepared statement on behalf of the applicant. She stated that there were concerns with the microbusiness registration. She said that the license allows them to apply for the uses contemplated in a microbusiness, but it was not an automatic ability to engage in all of those uses. She stated that if they wanted to grow, they would have to go through a process and receive City approval. She noted that the State had to approve. She responded to concerns from Council related to the bathroom which showed on the preliminary plans that it was not accessible to the public and clarified that usage was a good question that she could not answer because they did not occupy the building at this time. She said that they wanted to be a compliant business and partner with the communities.

Councilmember Larson asked why they did a microbusiness license rather than a retail license. Ms. White answered that there were not a lot of retail licenses available, so they applied for a microbusiness license.

Councilmember Larson expressed concerns about growing. Ms. White answered that they would have to apply for a new plan of record and go before the Planning Commission again. The Planning Commission could say no. She stated that they could not switch the type of license they had in a spot, and they would have to do the process over again.

Councilmember Larson thanked Ms. White for her time.

Motion: Councilmember Miller made a Motion to table the Forest Lake Cannabis Interim Use Permit until they can confer with legal about their recommendations, and the City Council can update their ordinance as appropriate.

Motion seconded by Councilmember Larson. Motion carried 5-0.



City Council

Regular Meeting

~ Minutes ~

1408 Lake Street South
Forest Lake, MN 55025
www.ci.forest-lake.mn.us

Monday, November 24, 2025

6:00 PM

City Center - Council Chamber

Community Development Director Wittman clarified the motion to update the ordinance to change the buffer. She asked for clarification whether they wanted an increased retail distance from residential or a buffer distance from residential. She asked if a 250-foot buffer from residential was appropriate or if they were comfortable if the residential was adjacent to the property.

Councilmember Erickson clarified that there was no buffer for residential.

Community Development Director Wittman answered that the other two interim use permits were approximately 150 feet to 350 feet from residential. She said that there was potential for long-term residential in an old strip motel very close. She stated that none were directly adjacent to residential, but she stated that this was not the only business that would be impacted if the other two interim use permits were microbusinesses.

Councilmember Miller said that he was not concerned about the retail, but the other types of use for microbusinesses. Community Development Director Wittman clarified that there were fewer concerns with retail next to residential, but they were concerned about the other aspects of the microbusinesses.

c) Resolution 11-24-25-06 – Met Council System Statement Objection – Abbi Wittman

Community Development Director Wittman revisited the item she brought forward at the November 17 workshop on the Met Council System Statement Objection. She stated that they were asking the Met Council to memorialize the density flexibilities so that the cities can achieve the densities. She said that they also wanted to ask for an amended forecast for the households based on development trends.

Motion: Councilmember Erickson made a Motion to approve Resolution 11-24-25-06, A Resolution Objecting to the Metropolitan Council’s Imagine 2050 City of Forest Lake System Statement and Requesting a Hearing.

Motion seconded by Councilmember Valento. Motion carried 5-0.

d) Franchise Fees – Mark Statz

City Administrator Statz explained the purpose of re-reviewing its franchise fee structure for electric and natural gas services for Xcel Energy and reviewing the franchise fee structure for Connexus Energy. He asked Council to consider:

- 1) Rescind Approval of Ordinances 760 and 761
- 2) Consider Ordinances 760, 761, 763
- 3) Consider Resolution 11-24-25-05 – Summary Publication of Ordinances 760, 761, 763



City Council

Regular Meeting

~ Minutes ~

1408 Lake Street South
Forest Lake, MN 55025
www.ci.forest-lake.mn.us

Monday, November 24, 2025

6:00 PM

City Center - Council Chamber

Motion: Councilmember Erickson made a Motion to Rescind 11/10/2025 Approval of Ordinances 760 and 761 (Xcel Energy), and approve Ordinances 760, 761, and 763 and Resolution 11-24-25-04: Summary Publication.
Motion seconded by Councilmember Larson. Motion carried 5-0.

9. Discussion

a) 2026 Budget Proposals – Mark Statz

City Administrator Statz reviewed the budget scenarios for the adoption of a 2026 Final Levy lower than the proposed preliminary levy. He reviewed the potential 2026 levy with a 9.25 percent increase over last year's, and the second scenario with an 8.9 percent increase over last year's levy.

Councilmember Erickson asked about the new revenue for the police. City Administrator Statz answered that the information was not included with the scenarios. He stated that the State came out with better numbers than anticipated for public safety.

Mayor Roberts asked about the public works maintenance operator and whether it was the same as the public works/parks operator. City Administrator Statz confirmed that they were in the same position. He said the Public Works Department included parks. He said that the intent was to offset additional hours spent in parks.

Public Works Director Adams discussed the work for parks being completed by the street department or utility department, so there was a need for an additional position. He stated that they were trying to balance out the hours spent in each department.

Councilmember Erickson said that there was a lot of weight given to parks, to the detriment of the utilities or the streets. Public Works Director Adams said that most time was spent on park activities.

Councilmember Erickson asked if they could rescind some of the level of service in parks to reconcile the difference. Public Works Director Adams discussed the difficulty of cutting back services for the parks. He said that families expect a level of services.

Mayor Roberts asked if medians and public spaces fell under parks. Public Works Director Adams confirmed this information.

Mayor Roberts asked if this hire would have specific knowledge of turf management or maintenance. He asked if there was a reason they were hiring at a certain wage. Public Works Director Adams answered that he always budgeted for a higher position, with the best-case scenario being that the City would be under budget for the position.



City Council

Regular Meeting

~ Minutes ~

1408 Lake Street South
Forest Lake, MN 55025
www.ci.forest-lake.mn.us

Monday, November 24, 2025

6:00 PM

City Center - Council Chamber

City Administrator Statz said they could always direct him to hire someone at a step one, but if they had a good candidate at a higher step, they would not be able to hire them. He requested feedback from the City Council on the two scenarios provided.

Mayor Roberts suggested presenting this information during the Truth and Taxation meeting to show that they tried to listen to the public will still providing reasonable services.

Councilmember Miller said that the tax levies in the counties were an 8.1 percent increase, and in the cities were an 8.7 percent increase. He was impressed with the work completed.

City Administrator Statz said that they would bring the information to the Truth and Taxation meeting.

Finance Director Larkin stated that they would see similar information at the Truth and Taxation meeting so that residents can understand the process.

b) 2026 City Meeting Calendar – Jolleen Chaika

Assistant City Administrator Chaika stated that the meeting calendar was changed in July to start at 6 p.m. She requested feedback about the 2026 City Meeting Calendar.

Council provided direction to proceed with 6:00 PM start times for all meeting groups if the commissions were supportive of the same.

10. Staff Updates

Finance Director Larkin invited any feedback or comments before the Truth and Taxation Meeting.

City Engineer Goodman said that equipment was dropped off at Eureka, and they were waiting for correspondence from the geotechnical subconsultant. They will put out message boards when they start the project. He will provide additional information before the actual start date.

Assistant City Administrator Chaika said that the new Deputy Clerk had been hired and would start soon. She said that the City Hall would be closed for Thanksgiving. She stated that Bolten & Menk would provide updates on Eureka Avenue.

Community Development Director Wittman said that the County approved the local affordable housing allocation support. She stated that she would talk with the Met Council and the County about ongoing operations and transportation. She thanked the City Council for their support in allowing them to hire additional staff this year.

Public Works Director Adams said that holiday decorations were installed. Hometown Holiday was on December 5th. He encouraged everyone to drive safely during the winter weather.



City Council

Regular Meeting

~ Minutes ~

1408 Lake Street South
Forest Lake, MN 55025
www.ci.forest-lake.mn.us

Monday, November 24, 2025

6:00 PM

City Center - Council Chamber

City Attorney Johnson said that they had passed an ordinance about bitcoin kiosks. She said that earlier this month, a woman was coerced into removing \$17,000 to put it into a bitcoin kiosk. She stated that she realized she had been scammed and put the money back in the bank. She thanked the City Council for removing the bitcoin kiosks in the City. She stated that all of the bitcoin kiosks were removed because the costs and administrative requirements of being an operator were not feasible.

City Administrator Statz said that the Airport Commission meeting would take place on December 3rd.

11. Mayor and City Council Updates

Councilmember Miller thanked Public Works Director Adams for the holiday decorations. He stated that one of the school board members had resigned, and there had been a lot of controversy, and a potential replacement would be nominated on December 3rd.

Councilmember Valento thanked the City staff for their hard work.

Councilmember Erickson thanked the City staff for the holiday lights.

12. Closed Session: Closed session pursuant to Minnesota Statutes § 13D.03 for labor negotiation strategy

Motion: Councilmember Erickson made a Motion to Move into Closed Session Pursuant to Minnesota Statutes §13D.03 for labor negotiation strategies.

Motion seconded by Councilmember Larson. Motion carried 5-0.

The Regularly Scheduled Council Meeting reconvened at 8:50p.m.

13. Adjourn

Motion: Councilmember Erickson made a Motion to Adjourn the Regularly Scheduled Council Meeting at 8:51 p.m.

Motion seconded by Councilmember Valento. Motion carried 5-0.

STAFF REPORT



MEETING DATE: January 12, 2026
TO: Honorable Mayor Roberts and Members of the City Council
STAFF ORIGINATOR: Jolleen Chaika, Assistant City Administrator
AGENDA ITEM: 2026 Annual Appointments

INTRODUCTION

Each year, the City Council makes annual appointments and designations for certain statutorily required services, including municipal depositories and the official legal newspaper, as well as other required or customary designations such as the selection of an Acting Mayor pursuant to Minn. Stat. § 412.121.

ANALYSIS

The table below identifies the proposed annual appointments and designations for 2026, with a comparison to those approved for 2025. No changes are recommended from the prior year's appointments or designations. While not all listed items are statutorily required, recommendations for consultant services and certain City positions are included for Council consideration as part of this annual action.

	2025	2026
Acting Mayor	Hanna Valento	Hanna Valento
Legal Newspaper	Forest Lake Times	Forest Lake Times
Municipal Advisor	Ehlers	Ehlers
City Depositories	- Midwest One Financial - 4M and 4MP Fund/PMA Financial Network - US Bank	- Midwest One Financial - 4M and 4MP Fund/PMA Financial Network - US Bank
City Attorney	Eckberg Lammers	Eckberg Lammers
Labor Services	Madden Galanter Hansen PLLC, Attorneys at Law	Madden Galanter Hansen PLLC, Attorneys at Law
Assessor	Washington County	Washington County

City Clerk	Jolleen Chaika	Jolleen Chaika
Data Practices Responsible Authority	Jolleen Chaika	Jolleen Chaika
Deputy Weed Inspector	None	Dan Pearson, Code Enforcement Officer
City Auditor	BerganKDV	BerganKDV
Secretarial Services	TimeSaver, Inc.	TimeSaver, Inc.

RECOMMENDATION

Staff recommends Council approve Resolution 01-12-26-01 designating the 2026 appointments as presented.

Assuming approval of all recommended consulting services, staff also recommends approval of the 2026 contract with Madden Galanter Hansen PLLC, Attorneys at Law and contract with TimeSavers Off-Site Secretarial Services, attached for review.

ATTACHMENTS

- Resolution 01-12-26-01
- Contract with Madden Galanter Hansen PLLC, Attorneys at Law
- Contract with TimeSavers Secretarial Services

**CITY OF FOREST LAKE
WASHINGTON COUNTY, MINNESOTA**

RESOLUTION NO. 01-12-26-01

A RESOLUTION APPROVING ANNUAL APPOINTMENTS

WHEREAS, the City of Forest Lake makes appointments and designations each year to provide transparency to residents and to meet requirements of Minnesota law; and,

WHEREAS, Minn. Stat. 412.121 requires that at its first meeting each year the Council shall choose an acting mayor from the council members. The acting mayor shall perform the duties of mayor during the disability or absence of the mayor from the city or, in case of vacancy in the office of mayor, until a successor has been appointed and qualifies; and,

WHEREAS, Minn. Stat. 412.831 requires that the Council, at the first regular meeting of the year, shall designate a legal newspaper as its official newspaper and that the Forest Lake Times is interested and qualified in continuing as the official newspaper for the City; and,

WHEREAS, Minn. Stat. 427.01 requires that a City shall designate banks as depository of City funds and the financial institutions as listed on this resolution are qualified depositories for City funds; and,

WHEREAS, the City wishes to include other pertinent appointments which are of significance to the daily operations of the City; and,

WHEREAS, the following list is recommended for approval for 2026:

	2025	2026
Acting Mayor	Hanna Valento	Hanna Valento
Legal Newspaper	Forest Lake Times	Forest Lake Times
Municipal Advisor	Ehlers	Ehlers
City Depositories	<ul style="list-style-type: none"> - Midwest One Financial - 4M and 4MP Fund/PMA Financial Network - US Bank 	<ul style="list-style-type: none"> - Midwest One Financial - 4M and 4MP Fund/PMA Financial Network - US Bank
City Attorney	Eckberg Lammers	Eckberg Lammers

Labor Services	Madden Galanter Hansen PLLC, Attorneys at Law	Madden Galanter Hansen PLLC, Attorneys at Law
Assessor	Washington County	Washington County
City Engineer	Bolton & Menk	Bolton & Menk
City Clerk	Jolleen Chaika	Jolleen Chaika
Data Practices Responsible Authority	Jolleen Chaika	Jolleen Chaika
Deputy Weed Inspector	None	Dan Pearson, Code Enforcement Officer
City Auditor	BerganKDV	BerganKDV
Secretarial Services	TimeSaver, Inc.	TimeSaver, Inc.

NOW THEREFORE, BE IT RESOLVED BY THE CITY COUNCIL OF THE CITY OF FOREST LAKE, MINNESOTA, hereby approves the above-listed appointments for 2026.

Adopted in the regular session of the Forest Lake City Council on the 12th day of January, 2026.

CITY OF FOREST LAKE

By:

 Blake Roberts
 Its Mayor

Attest:

 Jolleen Chaika
 Assistant City Administrator/Clerk

CONSULTING SERVICES CONTRACT

This Agreement, by and between the City of Forest Lake, hereinafter referred to as “City” and Madden Galanter Hansen, PLLC, Attorneys at Law, 7760 France Avenue South, Suite 290, Bloomington, Minnesota 55435-5834, hereinafter referred to as “Consultant.”

RECITALS

WHEREAS, the City is required under the Minnesota Public Employment Labor Relations Act (PELRA) to undertake the negotiations of contracts with employees represented by exclusive representatives (unions); and

WHEREAS, the City has determined that retaining a consultant to assist in its negotiations with the unions best fulfills its obligations with respect to labor negotiations.

NOW, THEREFORE, in consideration of the mutual undertakings and agreements contained within the Contract, the City and the Consultant agree as follows:

A. Scope of Services

1. Representation, with the labor negotiating team, in labor negotiations as chief management negotiator including:
 - a. Analysis of existing contract language and administration problems;
 - b. Preparation of management negotiations strategy;
 - c. Management spokesperson for “at the table” labor negotiations;
 - d. Preparation of management proposals and timely drafting of final labor bargaining agreement and finalization;
 - e. Pre-labor negotiation briefings, settlement summaries and appropriate status reports for the City Board information and action as necessary or as requested.
2. Management representation in grievance matters and counseling with management staff in initial grievance steps. Handling of grievance arbitrations.
3. Representation of the City in unit determination hearings.
4. Labor relations advice and personnel matters and data practices issues with the City on an ongoing basis.

B. Consideration and Terms of Payment

1. Consideration for all services performed shall be as follows:

Providing of labor negotiation services, travel and other labor relation services, other than arbitration, administrative hearing and litigation representation, billed in tenths of an hour at the rate of \$235.00 per hour. Arbitration and administrative hearing representation, if requested by the City, shall be at the rate of \$245.00 per hour.

2. Consultant will also be reimbursed for expenses, including mileage consistent with the amount set forth by the IRS per mile, photocopying charges at \$.15 per page, charges for facsimile transmissions at the rate of \$.50 per page, and reimbursement of long distance telephone charges.
3. The Consultant will submit invoices on a periodic basis to the City for payment for services performed. Payment shall be made within thirty days after receipt of invoices for services performed.

C. Changes

The City and Consultant may, from time to time, require changes in the terms of this Contract. Any such changes that are mutually agreed to by the parties shall be incorporated as written amendments to this Agreement and attached hereto.

D. Duration

The terms of this Agreement shall be applicable for a period commencing January 1, 2026 through December 31, 2026. The contract may also be terminated by either party after giving ninety (90) days written notice.

E. Independent Contractor

It is agreed by the parties that at all times and for all purposes hereunder, that the Consultant is an independent contractor and not an employee of the City.

F. Insurance

The Consultant agrees it will defend, indemnify and hold harmless the City, its officers and employees against any and all liability, loss, costs, damages and expenses which the City, its officers or employees may hereafter sustain, incur, or be required to pay arising out of the negligent or willful acts of omission of Consultant and out of Consultant's performance or failure to adequately perform its obligations pursuant to this Agreement.

The Consultant further agrees, in order to protect itself and the City under the indemnity provisions set forth above, the Consultant will maintain at all times general, professional,

and auto liability policies on an occurrence basis. All such policies shall provide limits not less than the tort liability limitations set forth in Minnesota Statutes Section 466.04. If applicable, the Consultant also agrees to maintain Workers Compensation insurance in the statutory amounts. Certificates of insurance showing the coverage listed here shall be during the term of this contract, have and keep in force liability insurance coverage provided to the City prior to the effective date of this contract. All policies shall provide that they shall not be canceled, materially changes, or not renewed without thirty days prior notice thereof to the City. This provision shall act as a condition subsequent; failure to abide by this provision shall be deemed as a substantial breach of contract.

G. Data Practices

The City shall disclose private and/or confidential data to Consultant as necessary for purposes of legal advice and consultation. Consultant agrees to abide by the applicable provisions of the Minnesota Government Data Practices Act, Minnesota Statutes, Chapter 13, pertaining to privacy or confidentiality. Consultant understands that all of the data created, collected, received, stored, used, maintained or disseminated by the Consultant in performing those functions that the City would perform as a government entity, is subject to the requirements of Chapter 13 and the Consultant must comply with those requirements as if it were a government entity. This does not create a duty on the part of the Consultant to provide the public with access to public data if the public data is available from the City, except as required by the terms of this Agreement.

IN WITNESS WHEREOF, the parties have caused the Contract to be duly executed intending to be bound thereby.

City of Forest Lake

Dated: _____

By: _____

Its _____

Madden Galanter Hansen, PLLC



Dated: 12/18/2025

By: _____

Susan K. Hansen
Its Partner

TimeSaver Off Site Secretarial, Inc.

October 1, 2025

Ms. Jolleen Chaika, Assistant City Administrator
City of Forest Lake
1408 Lake Street South
Forest Lake, MN 55025

Dear Jolleen,

Enclosed is an Addendum to the Recording Secretary Service Agreement that extends the expiration date to December 31, 2026. To accommodate COLA and the mandated family medical leave program, the 2026 unit rates reflect an increase of \$1.50 per hour and 50 cents per page. The base rate reflects an increase of less than 3.5%.

In January, TimeSaver will offer a new service to create CivicPlus meeting minutes. Please reach out if you're interested in additional information.

We appreciate the confidence you have placed in TimeSaver to handle your meeting minute needs and look forward to continuing that relationship in 2026.

If you need further information or have questions, please feel free to contact me at (612) 470-8199.

Best regards,

Shelby Zomermaand
Director of Operations

ADDENDUM TO RECORDING SECRETARY SERVICE AGREEMENT

Dated: December 31, 2025

By and between TimeSaver Off Site Secretarial, Inc. and the City of Forest Lake, 1408 Lake Street South, Forest Lake, MN 55025.

1. EXTENSION OF RECORDING SECRETARIAL SERVICE AGREEMENT: The term of the existing Agreement for Professional Services dated December 31, 2024, shall be extended under the same terms and conditions to December 31, 2026.
2. TOSS CHARGES: TOSS shall be paid for its services as recording secretary for each meeting with a one (1) hour minimum, the highest rate prevailing, as follows:
 - a. Base Rate: One Hundred Seventy-Eight and 00/100 dollars (\$178.00) for any meeting up to one (1) hour (billable time) plus Forty-One and 50/100 dollars (\$41.50) for each thirty (30) minutes following the first one (1) hour; **or**
 - b. Unit Rate: Fifty-Seven and 00/100 dollars (\$57.00) for the first hour of meeting time and Thirty-Eight and 00/100 dollars (\$38.00) for every hour after the first hour plus Seventeen and 75/100 dollars (\$17.75) for each page of draft minutes for submission to the City of Forest Lake for their preparation of final minutes.

At the end of the term of this Addendum or any extension of it, the parties may make a new Agreement or extend or modify the terms of this Agreement.

IN WITNESS WHEREOF, the undersigned have executed this Addendum to the Recording Secretary Service Agreement as of the day and year indicated.

January , 2026

CITY OF FOREST LAKE

By: _____
Jolleen Chaika

Its: Assistant City Administrator

October 1, 2025

TIMESAVER OFF SITE SECRETARIAL, INC.

Kristin Wirth
By: _____
Kristin Wirth

Its: CFO

STAFF REPORT



MEETING DATE: January 12, 2026

TO: Honorable Mayor Roberts and City Council Members

STAFF ORIGINATOR: Jolleen Chaika, Assistant City Administrator/Clerk

AGENDA ITEM: Tobacco License for New Ownership of Highway 61 Stop and Go

INTRODUCTION:

Highway 61 Stop and Go will be under new ownership effective December 31, 2025 and will be renamed Kitty's Corner 5, incorporated as Lake Street Corporation; the new owner has applied for a Tobacco License to allow for continued sale of tobacco/nicotine products upon issuance of the new license. Because the sale was conducted before the applicant contacted the city to ensure compliance with tobacco licensing requirements, the new owner has not been permitted to sell tobacco products since taking on ownership. Sales will resume following issuance of this license. The applicant has also submitted a renewal application for the licensing period which will begin on February 1, 2026,.

ANALYSIS:

A background check is being conducted by the Forest Lake Police Department. City staff has reviewed all requisite application submissions and has determined that the applicant meets all current city ordinance requirements as well as state requirements.

The full license application is available for review in the Clerk's Office.

RECOMMENDATION:

Approve Resolution 01-12-26-02 authorizing issuance of a Tobacco License through January 31, 2026.

ATTACHMENTS:

Resolution 01-12-26-02

**CITY OF FOREST LAKE
WASHINGTON COUTNY, MINNESOTA**

**Resolution 01-12-26-02
Approving New Tobacco License**

WHEREAS, the City of Forest Lake requires all businesses offering for sale any tobacco/nicotine products to submit a city-approved application for a Tobacco License; and

WHEREAS, Lake Street Incorporated, DBA Kitty's Corner 5, has purchased Highway 61 Stop and Go, located at 408 Lake Street South; and

WHEREAS, Lake Street Incorporated will take over operations of the business on December 31, 2025; and

WHEREAS, Lake Street Incorporated wishes to continue operations including the sale of tobacco/nicotine products; and;

WHEREAS, Lake Street Incorporated has submitted a complete application to the City Clerk's Office and has submitted to a background check.

NOW, THEREFORE, BE IT RESOLVED by the City Council of the City of Forest Lake, Minnesota, that:

The City hereby approves the issuance of a Tobacco License to Lake Street Incorporated, DBA Kitty's Corner 5, contingent upon successful background check. The license shall be effective until January 31, 2026, unless cancelled or revoked prior to that date.

Adopted by the City Council of the City of Forest Lake this 12th day of January, 2026.

Blake Roberts, Mayor

ATTEST:

Jolleen Chaika, Assistant City Administrator/Clerk

STAFF REPORT



MEETING DATE: January 12, 2026

TO: Honorable Mayor Roberts and Members of the City Council

STAFF ORIGINATOR: Jolleen Chaika, Assistant City Administrator/Clerk

AGENDA ITEM: Annual License Renewals

INTRODUCTION:

Each year the City renews Liquor, Tobacco, and Massage Business/Therapist licenses to ensure compliance with all local and state laws and regulations and to enhance accountability and compliance.

ANALYSIS:

Staff has received renewal applications from the license holders as listed in the attached resolution. Background checks have been completed by the Forest Lake Police Department; staff has reviewed compliance history, reviewed applications for completeness, and ensured adequate insurance is in place for all license holders. Based upon a thorough review by the City Clerk and Forest Lake Police Department, all renewal applicants meet the requirements for license renewal for the February 1, 2024 – January 31, 2026 license period.

It is important to note that several liquor and tobacco license holders did fail compliance checks conducted by the police department in late 2025; however, those compliance check failures do not preclude the license holders from renewal of their licenses. Staff will be bringing forward separate actions at a future meeting for the Council to consider administrative penalties for compliance check failures.

RECOMMENDATION:

Staff recommends approval of Resolution 01-12-26-03

ATTACHMENTS:

Resolution 01-12-26-03

**CITY OF FOREST LAKE
WASHINGTON COUNTY, MINNESOTA**

RESOLUTION NO. 01-12-26-03

APPROVING RENEWALS OF LIQUOR, TOBACCO, AND MASSAGE LICENSES

WHEREAS, the City issues annual licenses to establishments which sell alcoholic beverages, tobacco products, and businesses and therapists which offer massage services; and

WHEREAS, the City's annual licensing period runs from February 1 through January 31 of each year; and

WHEREAS, the businesses as listed on Exhibit A have applied for a license renewal; and;

WHEREAS, upon completion of the background investigations, the Forest Lake Police Department found nothing to preclude issuance of these licenses; and,

WHEREAS, the City Clerk has reviewed the application materials and has found the application materials to be in conformance with City code and, specific to liquor licenses, state statute; and;

NOW, THEREFORE, BE IT RESOLVED BY THE CITY COUNCIL OF THE CITY OF FOREST LAKE, that the City Council does hereby approve renewal of the licenses as provided in Exhibit A, contingent upon the applicants meeting all state and local requirements for said licenses.

Adopted in the regular session of the Forest Lake City Council on the 12th day of January, 2026.

CITY OF FOREST LAKE

By: _____
Blake Roberts
Its Mayor

Attest: _____
Jolleen Chaika
Assistant City Administrator/Clerk

EXHIBIT A

License Type	License Holder
TOBACCO	Horizon Enterprises DBA Circle E Wine & Spirits
TOBACCO	Forest Lake 2000 LLC DBA Cub Foods
TOBACCO	Forest Lake Tobacco (668 Lake St S)
TOBACCO	Forest Lake Tobacco Inc (221 12 th St SW)
TOBACCO	Forest Lake E-Cig, DBA Fog E-Cig
TOBACCO	Forever Green Liquors DBA Westlake Liquor Warehouse
TOBACCO	Holiday Stationstore #2746236
TOBACCO	Holiday Stationstore #2746253
TOBACCO	Holiday Stationstore #2746311
TOBACCO	Kitty's Korner 5
TOBACCO	Karmon Incorporated, DBA Karl's Korner
TOBACCO	Kwik Trip, Inc DBA Kwik Trip
TOBACCO	DB Liquor LLC, DBA Liquor Works
TOBACCO	KSIALL Company DBA MGM Wine & Spirits
TOBACCO	FKG Oil Company DBA Forest Lake MotoMart
TOBACCO	SBD Collective LLC, DBA Nothing But Hemp
TOBACCO	T&L LLC, DBA Smokes N More
TOBACCO	Northern Tier Retail LLC DBA Speedway
TOBACCO	Tanners Brook LP, DBA Tanners Brook Golf Course
TOBACCO	Walgreens #07111
TOBACCO	Wal-Mart
MASSAGE THERAPIST	Janette Collins
MASSAGE THERAPIST	Kay Ketchum
MASSAGE THERAPIST	Kaylee Gale
MASSAGE THERAPIST	Laura Olds
MASSAGE THERAPIST	Theresa Tryman
MASSAGE THERAPIST	Tara Steenblock
MASSAGE LOCATION	S&S SalonSpa, DBA Adevia
MASSAGE LOCATION	Essential Massage Therapy
MASSAGE LOCATION	LaGrande Beauty Spa and Boutique
MASSAGE LOCATION	Massage by K's Caring Hands
MASSAGE LOCATION	MELO LLC
MASSAGE LOCATION	Minnesota Vitality and Anti-Aging Clinic
MASSAGE LOCATION	Salon EnV
MASSAGE LOCATION	Tara's Place
MASSAGE LOCATION	Timeless Elements Med and Laser Spa
3.20FSL	Forest Lake 2000 LLC DBA Cub Foods
3.20FSL	Kwik Trip, Inc DBA Kwik Trip
3.20FSL	Northern Tier Retail LLC DBA Speedway
MCLONSS	American Legion 225
MCLONSS	Forest Hills Golf Club Inc, DBA Forest Hills Golf Club
MCLONSS	Forest Lake VFW Post 4210
MWNONSB	D&D Of Minnesota, DBA Famous Dave's

MWNONSB	New Joy Garden MN, Inc DBA Joy Garden
MWNONSB	Comes Investments, DBA Pizza Hut
MWNONSB	JP Wells Inc. DBA Keys Café and Bakery
MWNONSB	Solis VJ LLC, DBA The Best Steak House Plus
MWNONSB	New Joy Garden MN Inc, DBA Joy Garden
MWNONSB	Zavala Foods Inc, DBA Rubio's on 61
OFSL	Karmon Incorporated, DBA Karl's Korner
OFSL	Horizon Enterprises DBA Circle E Wine & Spirits
OFSL	KSIALL Company DBA MGM Wine & Spirits
OFSL	Forever Green Liquors LLC, DBA Westlake Warehouse Liquors
OFSL	Wine & Roses Liquors Inc, DBA Wine & Roses Liquors
OFSL	DB Liquor LLC, DBA Liquor Works
ONSS	Apple Minnesota LLC, DBA Applebee's Neighborhood Grill & Bar
ONSS	Foursome Golf Management Group LLC, DBA Castlewood Golf Course
ONSS	Ashew Holdings LLC, DBA Friar Tucks
ONSS	Don Julio Authentic Mexican Restaurant
ONSS	Mallards MN, DBA Mallards
ONSS	Other Guy's LLP, DBA Norman Quacks
ONSS	Old Log Cabin Inc, DBA Old Log Cabin
ONSS	Pizza Pub of Forest Lake LLC, DBA Pizza Pub
ONSS	Rasa Ruelas LLC, DBA Rancho Loco
ONSS	VMRR LLC DBA Shoreside Bar & Grill
ONSS	Morales Food Inc, DBA Stella's on 97
ONSS	Tanners Brook LP, DBA Tanners Brook Golf Course
ONSS	VR Companies LLC, DBA The Grillium
ONSS	Zoukmaya LLC, DBA Zoukmaya Restaurant
3.2OFSL	Forest Lake 2000 LLC DBA Cub Foods
3.2OFSL	Kwik Trip, Inc DBA Kwik Trip
3.2OFSL	Northern Tier Retail LLC DBA Speedway

**CITY OF FOREST LAKE
WASHINGTON COUNTY, MINNESOTA**

RESOLUTION NO. 01-12-26-04

RESOLUTION ACCEPTING VETERANS MEMORIAL PROJECT DONATIONS

WHEREAS, the following persons and businesses/organizations have made donations to the Veterans Memorial Project totaling \$28,230;

Hallberg Family Foundation (\$25,000)
James Kohler (\$150)
WDI Companies (\$150)
Nannette Lanasa (\$30)
LPL Financial (\$500)

Acuworks LLC (\$250)
Jerry Saunders (\$2,000)
John Fries (\$50)
Mattson Funderal Home (\$100)

WHEREAS, these donations were made for the purpose of building the Veterans Memorial Project; and,

WHEREAS, the Forest Lake City Council is appreciative of the donation and finds that it is appropriate to accept the donation offered; and,

NOW THEREFORE, BE IT RESOLVED, by the City Council of the City of Forest Lake Minnesota, that:

1. The donation is accepted and acknowledged with gratitude;
2. The donation will be appropriated for the City of Forest Lake as designated; and,
3. The Finance Director is authorized to make the appropriate budget adjustment to account for the donation and related expenses.

Adopted in the regular session of the Forest Lake City Council on the 12th day of January 2026.

CITY OF FOREST LAKE

By: _____
Blake Roberts
Its Mayor

Attest: _____
Jolleen Chaika
Assistant City Administrator

**CITY OF FOREST LAKE
WASHINGTON COUNTY, MINNESOTA**

RESOLUTION NO. 01-12-26-05

RESOLUTION OF GRADITUDE FOR THE 2025 HOMETOWN HOLIDAY EVENT

WHEREAS, the following volunteers dedicated their time and efforts to the City of Forest Lake Hometown Holiday Event on Friday, December 5, 2025;

Janet Nutter	Alexis Gjerning	Maija Norwood	Chelsea Erickson
Jeff Larson	Cheri Peterson	Cheri Santanni	Sherri Hernandez
Tamara "T" Jotblad	Bill Murphy	Glen Neville	Samantha Maciej
Keith Kuhnly	Jayne Kuhnly	Shandra Haverty	Neil Peterson
Spencer Harvey	Isabella Mckenzie	Theresa Ryan	Rodney Korwarsch
Joy Korwarsch	Kevin McDowell	Megan McDowell	Nancy Daschel
Katie Lindstrom	Trevor Lindstrom	Wendy Arend	Cassey Kotek
Marc Sieber	Sue Herdina	Karen Morehead	

WHEREAS, the Forest Lake City Council is appreciative of their volunteerism to support this City event;

NOW THEREFORE, BE IT RESOLVED, by the City Council of the City of Forest Lake Minnesota, acknowledges sincere appreciation and gratitude to these volunteers.

Adopted in the regular session of the Forest Lake City Council on the 12th day of January, 2026.

CITY OF FOREST LAKE

By: _____
Blake Roberts
Its Mayor

Attest: _____
Jolleen Chaika
Assistant City Administrator

**CITY OF FOREST LAKE
WASHINGTON COUNTY, MINNESOTA**

RESOLUTION NO. 01-12-26-06

ACCEPTING DONATION FOR HOMETOWN HOLIDAY EVENT

WHEREAS, the following businesses have submitted a donation to the City of Forest Lake's Hometown Holiday Event in the following amounts:

Thrivent - Leif Erickson – Petting Zoo & Fire Pit: \$1050
 Labelle Realty - Chelsea Erickson – Santa Experience: \$1000
 Bolton & Menk – Entertainment: \$500
 Xcel Energy – Tree Lighting: \$500
 The Yoga Branch at Forest Lake – Fire Pit: \$300
 Carney Insurance Services – Fire Pit: \$300
 Drolson Family Foundation – Fire Pit: \$300
 Empire Insurance – Fire Pit: \$300
 Pizza Pub of Forest Lake – S'mores Roasting Sticks: \$150
 Barno and Langness Consulting – General Ambiance: \$150
 Minnesota Frost and Flames BBQ – General Ambiance: \$150

WHEREAS, the following businesses donated an in-kind donation to the City of Forest Lake's Hometown Holiday Event;

Pizza Pub of Forest Lake – S'Mores
 Lakes Floral Gift & Garden – Greenery Decoration
 Spikes & Houles – Christmas Planters
 Kodiak Coffee – Hot Cocoa

WHEREAS, the listed businesses made these donations for the purpose of sponsoring the City of Forest Lake's Hometown Holiday Event; and,

WHEREAS, the Forest Lake City Council is appreciative of the donation and finds that it is appropriate to accept the donation offered; and,

NOW THEREFORE, BE IT RESOLVED, by the City Council of the City of Forest Lake Minnesota, that:

1. The donation is accepted and acknowledged with gratitude;
2. The donation will be appropriated for the City of Forest Lake as designated; and,
3. The Finance Director is authorized to make the appropriate budget adjustment to account for the donation and related expenses.

Adopted in the regular session of the Forest Lake City Council on the 12th day of January, 2026.

CITY OF FOREST LAKE

By: _____
Blake Roberts
Its Mayor

Attest: _____
Jolleen Chaika
Assistant City Administrator

STAFF REPORT



MEETING DATE: January 12, 2026

TO: Mayor and City Council

STAFF ORIGINATOR: Jolleen Chaika – Assistant City Administrator

AGENDA ITEM: City of Forest Lake – LELS #111 Collective Bargaining Agreement

INTRODUCTION:

LELS #111's (representing patrol officers) collective bargaining agreement (CBA) expired on December 31, 2025; under Minnesota law, that CBA remains in effect until a new CBA is ratified. Following Council's authority related to negotiations for the new contract period, staff met with the union in good faith and successfully reached an agreement for the new contract period of January 1, 2026 – December 31, 2028. A redlined contract is attached for review. Some of the changes contemplated in the agreement include:

- **Wages:** The agreement includes moving LELS membership from the previous LELS #111 wage schedule to the 2026 6-step City-wide salary schedule as adopted by the City Council following the classification and compensation study.
- **Health Benefits:** Updates to contribution levels for 2026-2028, consistent with other bargaining units.
- **Separation Pay:** Changes to payout of sick time in the event of an employee's death.
- **Paid Leave:** Language to permit top-off by use of sick or vacation time in the event of a paid leave claim.
- **Service Credit for Vacation Accrual – New Staff:** Language to provide for service credit for calculating vacation accrual for new LELS staff.

Other changes are redlined in the attached agreement.

RECOMMENDATION:

Staff recommends Council move **to approve 2026-2028 Agreement between LELS #111 and the City of Forest Lake.**

ATTACHMENTS:

Agreement between LELS #111 and the City of Forest Lake.

AGREEMENT

between

THE CITY OF FOREST LAKE



and

LAW ENFORCEMENT LABOR SERVICES, INC.

(LELS Local #111)



January 1, ~~2023-2026~~ thru December 31, ~~2025~~2028

Contents

ARTICLE 1 – PURPOSE.....	4
ARTICLE 2 - RECOGNITION	4
ARTICLE 3 - DEFINITIONS.....	4
ARTICLE 4 – EMPLOYER SECURITY.....	5
ARTICLE 5 – EMPLOYER AUTHORITY	5
ARTICLE 6 – UNION SECURITY	5
ARTICLE 7 – EMPLOYEE RIGHTS – GRIEVANCE PROCEDURE	5
ARTICLE 8 – SAVINGS CLAUSE	8
ARTICLE 9 - SENIORITY.....	8
ARTICLE 10 - DISCIPLINE	9
ARTICLE 11 - SEVERANCE	10
ARTICLE 12 - VACATIONS.....	10
ARTICLE 13 – SICK LEAVE.....	11
ARTICLE 14 - LEAVE	11
ARTICLE 15 – HOLIDAY PAY	12
ARTICLE 16 – WORK SCHEDULES.....	12
ARTICLE 17 – CALLS TO DUTY	12
ARTICLE 18 – COURT CANCELLATION.....	13
ARTICLE 19 - OVERTIME	13
ARTICLE 20 – UNIFORM ALLOWANCE	13
ARTICLE 21 – FALSE ARREST INSURANCE	14
ARTICLE 22 - BONDING.....	14
ARTICLE 23 – HEALTH AND DENTAL INSURANCE	14
ARTICLE 24 – HEALTH CARE SAVINGS PLAN.....	15
ARTICLE 25 – FUNERAL LEAVE.....	16
ARTICLE 26 – LIFE INSURANCE	16
ARTICLE 27 – FIELD TRAINING OFFICER (F.T.O.) COMPENSATION	16
ARTICLE 28 – POST LICENSE FEE.....	17
ARTICLE 29 – INVESTIGATORS PAY.....	17
ARTICLE 30 – CANINE OFFICER.....	17
ARTICLE 31 – LONG TERM DISABILITY	17
ARTICLE 32 - EDUCATIONAL	17

ARTICLE 33 – FLEXIBLE SPENDING ACCOUNT18

ARTICLE 34 – INJURY ON DUTY LEAVE18

ARTICLE 35 – PART TIME EMPLOYEE BENEFITS.....19

ARTICLE 36 - WAIVER19

ARTICLE 37 – DURATION19

APPENDIX A - WAGE SCHEDULE.....22

APPENDIX B - TUITION REIMBURSEMENT/EDUCATIONAL INCENTIVE23

APPENDIX C – UNIFORM LIST25

ARTICLE 1 – PURPOSE

This agreement is hereby made and entered into by and between the City of Forest Lake hereinafter referred to as the EMPLOYER, and the Law Enforcement Labor Services, Inc., hereinafter referred to as the UNION.

It is the purpose and intent of this agreement to:

- 1.1 Establish procedures for the resolution of disputes concerning this agreement's interpretation and/or application; and
- 1.2 Place in written form the parties' agreement upon terms and conditions of employment for the duration of this agreement.

ARTICLE 2 - RECOGNITION

2.1 The EMPLOYER recognizes the UNION as the exclusive representative for all police personnel in the following unit:

All peace officers employed by the Forest Lake Police DEPARTMENT, Forest Lake, Minnesota, within the meaning of Minn. Stat. 179A.03 Subd. 7, excluding supervisory confidential and all other EMPLOYEES.

2.2 In the event the EMPLOYER and the UNION are unable to agree as to the inclusion or exclusion of a new or modified job class, the issue shall be submitted to the Bureau of Mediation Services for determination.

ARTICLE 3 - DEFINITIONS

- 3.1 UNION: Law Enforcement Labor Services, In.
- 3.2 UNION MEMBER: A member of Local No. 111 of Law Enforcement Labor Services, Inc.
- 3.3 EMPLOYEE: A member of the exclusively recognized bargaining unit.
- 3.4 DEPARTMENT: The City of Forest Lake Police DEPARTMENT
- 3.5 EMPLOYER: The City of Forest Lake
- 3.6 SCHEDULED SHIFT: A consecutive work period including REST BREAKS and a LUNCH BREAK.
- 3.7 REST BREAKS: Periods during the SCHEDULED SHIFT during which the EMPLOYEE remains on continual duty and is responsible for assigned duties.
- 3.8 LUNCH BREAK: A period during the SCHEDULED SHIFT during which the EMPLOYEE remains on continual duty and is responsible for assigned duties.

3.9 PROBATION PERIOD:EMPLOYEES shall be probationary during the first one (1) year of employment, from the most recent date of hire. During this period an EMPLOYEE may be discharged at the discretion of the EMPLOYER.

ARTICLE 4 – EMPLOYER SECURITY

4.1 The UNION agrees that during the lift of this agreement that the UNION will not cause, encourage, participate in or support any strike, slow-down or other interruption of or interference with the normal function of the EMPLOYER.

ARTICLE 5 – EMPLOYER AUTHORITY

5.1 The EMPLOYER retains the full and unrestricted right to operate and manage all manpower, facilities and equipment; to establish functions and programs; to set and amend budgets; to determine the utilization of technology; to establish and modify the organizational structure; to select, direct and determine the number of personnel; to establish work schedules; and to perform any inherent managerial function not specifically limited by this agreement.

5.2 Any “term or condition of employment” not specifically established by this agreement shall remain solely within the discretion of the EMPLOYER to establish, modify or eliminate.

ARTICLE 6 – UNION SECURITY

6.1 The EMPLOYER shall deduct from the wages of EMPLOYEES who authorize such a deduction in writing an amount necessary to cover monthly UNION dues. Such monies shall be remitted as directed by the UNION.

6.2 The UNION may designate EMPLOYEES from the bargaining unit to act as Steward and an alternate and shall inform the EMPLOYER in writing of such choice and changes in the position of Steward and/or alternate.

6.3 The EMPLOYER shall make space available on the EMPLOYEE bulletin board for posting of UNION notice(s) and announcements.

6.4 The UNION agrees to indemnify and hold the EMPLOYER harmless against any and all claims, suits, orders, or judgments brought or issued against the EMPLOYER as a result of any action taken or not taken by the EMPLOYER under the provision of this article.

ARTICLE 7 – EMPLOYEE RIGHTS – GRIEVANCE PROCEDURE

7.1 Definition of a Grievance: A grievance is defined as a dispute or disagreement as to the interpretation or application of the specific terms and conditions of this agreement.

7.2 UNION Representatives: The EMPLOYER will recognize Representatives designated by the UNION as the grievance representatives of the bargaining unit having the duties and responsibilities established by this article. The UNION shall notify the EMPLOYER in writing of the names of such UNION Representatives and of their successors when so designated as provided by 6.2 of this agreement.

7.3 Processing of a grievance: It is recognized and accepted by the UNION and the EMPLOYER that the processing of grievances as hereinafter provided is limited by the job duties and responsibilities of the EMPLOYEES and shall therefore be accomplished during normal working hours only when consistent with such EMPLOYEE duties and responsibilities. The aggrieved EMPLOYEE and a UNION representative shall be allowed a reasonable amount of time without loss in pay when a grievance is investigated and presented to the EMPLOYER during normal working hours provided that the EMPLOYEE and the UNION Representative have notified and received the approval of the designated supervisor who has determined that such absence is reasonable and would not be detrimental to the work programs of the EMPLOYER.

7.4 Procedure: Grievances, as defined by Section 7.1, shall be resolved in conformance with the following procedure:

Step 1: _____ An EMPLOYEE claiming a violation concerning the interpretation or application of this agreement shall, within twenty-one (21) calendar days after such alleged violation has occurred, present such grievance to the EMPLOYEE's supervisor as designated by the EMPLOYER. The EMPLOYER-designated Representative will discuss and give and answer to such Step 1 grievance within ten (10) calendar days after receipt. A grievance not resolved in Step 1 and appealed to Step 2 shall be placed in writing setting forth the nature of the grievance, the facts on which it is based, the provision or provisions of the agreement allegedly violated. The remedy requested, and shall be appealed to Step 2 within ten (10) calendar days after the EMPLOYER-designated representative's final answer in Step 1. Any grievance not appealed in writing to Step 2 by the UNION within ten (10) calendar days shall be considered waived.

Step 2: _____ If appealed, the written grievance shall be presented by the UNION and discussed with the EMPLOYER-designated Step 2 Representative. The EMPLOYER-designated Step 2 Representative shall give the UNION the EMPLOYER's Step 2 answer in writing within ten (10) calendar days after receipt of such Step 2 grievance. A grievance not resolved in Step 2 may be appealed to Step 3 within ten (10) calendar days following the EMPLOYER-designated Representative's final Step 2 answer. Any grievance not appealed in writing to Step 3 by the UNION within ten (10) calendar days shall be considered waived.

Step 3: _____ If appealed, the written grievance shall be presented by the UNION and discussed with the EMPLOYER-designated Step 3 Representative. The EMPLOYER-designated

Representative shall give the UNION the EMPLOYER's answer in writing within ten (10) calendar days after receipt of such Step 3 grievance. A grievance not resolved in Step 3 may be appealed to Step 4 within ten (10) calendar days following the EMPLOYER-designated Representative's final answer in Step 3. Any grievance not appealed in writing to Step 4 by the UNION within ten (10) calendar days shall be considered waived.

Step 4: _____ A grievance unresolved in Step 3 and appealed to Step 4 by the UNION shall be submitted to arbitration ~~subject to rules published by the State of Minnesota Bureau of Mediation Services.~~ For grievance matters involving written disciplinary action, discharge, or termination, the assignment of an arbitrator shall be consistent with Minnesota Statute 626.892. For all other grievances the selection of an arbitrator shall be made in accordance with the "Rules Governing the Arbitration of Grievances" as established by the Bureau of Mediation Services.

7.5 Arbitrator's Authority

A. The arbitrator shall have no right to amend, modify, nullify, ignore, add to or subtract from the terms and conditions of this agreement. The arbitrator shall consider and decide only the specific issue(s) submitted in writing by the EMPLOYER and the UNION and shall have no authority to make a decision on any other issue not so submitted.

B. The arbitrator shall be without power to make decisions contrary to, or inconsistent with, or modifying or varying in any way the application of laws rules or regulations having the force and effect of law. The arbitrator's decision shall be submitted in writing within thirty (30) days following the close of the hearing or submission of briefs by the parties, whichever be later, unless the parties agree to an extension. The decision shall be binding on both the EMPLOYER and the UNION and shall be based solely on the Arbitrator's interpretation or application of the express terms of the agreement and to the facts of the grievance presented.

C. The fees and expenses for the Arbitrator's services and proceedings shall be borne equally by the EMPLOYER and the UNION provided that each party shall be responsible for compensating its own representatives and witnesses. If either party desires a verbatim record of the proceedings, it may cause such a record to be made, providing it pays for the record. If both parties desire a verbatim record of the proceedings the cost shall be shared equally.

D. If the UNION files for mediation leading to interest arbitration, the EMPLOYER reserves the right to select conventional interest arbitration; or final offer issue by issue interest arbitration. By mutual agreement the parties may elect final offer total package interest arbitration.

E. If the EMPLOYER files for mediation leading to interest arbitration, the UNION reserves the right to select conventional interest arbitration; or final offer issue by issue interest

arbitration. By mutual agreement the parties may elect final offer total package interest arbitration.

7.6 Waiver: If a grievance is not presented within the time limits set forth above, it shall be considered "waived." If a grievance is not appealed to the next step within the specified time limit or any agreed extension thereof, it shall be considered settled on the basis of the EMPLOYER's last answer. If the EMPLOYER does not answer a grievance or an appeal thereof within the specified time limits, the UNION may elect to treat the grievance as denied at that step and immediately appeal the grievance to the next step. The time limit in each step may be extended by mutual written agreement of the EMPLOYER and the UNION in each step.

7.7 Choice of Remedy: If, as a result of the written EMPLOYER response in Step 3 of the grievance remains unresolved, and if the grievance involves the suspension, demotion or discharge of an EMPLOYEE who has completed the required probationary period, the grievance may be appealed either to Step 4 of Article 7 or to the Veteran's Preference if the EMPLOYEE is a veteran. If appealed to Veteran's Preference the grievance is not subject to the arbitration procedure as provided in Step 4 of Article 7. The aggrieved EMPLOYEE shall indicate in writing which procedure is to be utilized Step 4 of Article 7 or Veteran's Preference – and shall sign a statement to the effect that the choice precludes the aggrieved EMPLOYEE from making a subsequent appeal through Step 4 of Article 7.

ARTICLE 8 – SAVINGS CLAUSE

This agreement is subject of the laws of the United States, the State of Minnesota and the City of Fores Lake. In the event any provision of the agreement shall be held to be contrary to law by a court of competent jurisdiction from whose final judgment or decree no appeal has been taken within the time provided, such provisions(s) shall be voided. All other provisions of this agreement shall continue in full force and effect. The voided provision may be renegotiated at the written request of either party.

ARTICLE 9 - SENIORITY

9.1 Seniority shall be determined by the EMPLOYEE's length of continuous employment with the Police DEPARTMENT and posted in an appropriate location. Seniority rosters may be maintained by the Chief on the basis of time in grade and time within specific classifications.

9.2 During the probationary period a newly hired or rehired EMPLOYEE may be discharged at the sole discretion of the EMPLOYER. During the probationary period a promoted or reassigned EMPLOYEE may be replaced in the EMPLOYEE's previous position at the sole discretion of the EMPLOYER.

9.3 A reduction of work force will be accomplished on the basis of seniority.

EMPLOYEES shall be recalled from layoff on the basis of seniority. An EMPLOYEE on layoff shall have an opportunity to return to work within one year of the time of the EMPLOYEE's layoff before any new EMPLOYEE is hired.

9.4 Senior EMPLOYEES shall be given preference with regards to transfer, job classifications assignments and promotion when the job-relevant qualifications of EMPLOYEES are equal.

9.5 Senior EMPLOYEES shall be given shift assignment preference after twelve (12) months of continuous full-time employment.

9.6 One continuous vacation period shall be selected on the basis of seniority until such time specified by the Chief of Police during the calendar year.

ARTICLE 10 - DISCIPLINE

10.1 The EMPLOYER will discipline EMPLOYEE for just cause only. Discipline will be in one or more of the following forms:

- a. Oral reprimand;
- b. Written reprimand;
- c. Suspension;
- d. Demotion; or
- e. Discharge.

10.2 Suspension, demotions and discharges will be in written form.

10.3 Written reprimands, notices of suspension, and notices of discharge which are to become part of an EMPLOYEE's personnel file shall be read and acknowledged by signature of the EMPLOYEE. The EMPLOYEE(s) and the UNION will receive a copy of such reprimands and/or notices.

10.4 EMPLOYEES may examine their own individual personnel files at reasonable times under the direct supervision of the EMPLOYER.

10.5 Discharges will be preceded by a five (5) day suspension without pay.

10.6 An EMPLOYEE will not be questioned concerning an investigation of disciplinary action unless the EMPLOYEE has been given an opportunity to have a UNION representative present at such questioning.

10.7 Grievances relating to this Article shall be initiated by the UNION in Step 3 of the grievance procedure under Article 7.

ARTICLE 11 - SEVERANCE

11.1 Vacation time and compensatory time will be paid on termination.

11.2 EMPLOYEES will be paid severance into their Health Care Savings Plan pay as follows:

- A. After (10) years of service to the City of Forest Lake-Sixty percent (60%) of unused sick leave up to a maximum of 360 hours.
- B. After fifteen (15) years of service – Sixty percent (60%) of unused sick leave to a maximum of 440 hours.
- C. After twenty (20) years of service – Sixty percent (60%) of unused sick leave to a maximum of 720 hours.

11.3 After twenty (20) years of service an EMPLOYEE in good standing will receive their duty weapon.

11.4 In the event of the employee's death, payment due to the employee under this Article shall be paid to the employee's beneficiary or estate and not deposited into the Health Care Savings Plan outlined in Article 24. In the event of the employee's death prior to ten (10) years of service to the City, 60% of unused sick leave, up to a maximum pro-rata calculation of unused sick leave pursuant to provision 11.2 a. above, shall be paid to the employee's beneficiary or estate (e.g., After five (5) years of service to the City, sixty (60%) percent of unused sick leave, up to a maximum of 180 hours).

ARTICLE 12 - VACATIONS

12.1 EMPLOYEES shall accrue vacation leave time as determined by the EMPLOYEE's anniversary date based upon the following schedule:

Years of Service	Annual Hours	Pay Period Hours
From 0 Years Thru 5 Years	80 <u>120</u>	3.07694 <u>.6154</u>
After 5 Years Thru 10 Years	120 <u>160</u>	4.61546 <u>.1538</u>
After 10 Years Thru 15 Years	160 <u>176</u>	6.15386 <u>.7692</u>
After 15 Years Thru 20 Years	176 <u>200</u>	6.76927 <u>.6923</u>
After 20 Years	200 <u>216</u>	7.69238 <u>.3077</u>

12.2 Vacation accrual rates will be applied in January of each year, at the accrual rate that corresponds to each EMPLOYEE's anniversary date. An EMPLOYEE is eligible to receive the new accrual rate level in January of the year that the EMPLOYEE would reach the new level in accordance with the EMPLOYEE's anniversary date and the above schedules.

~~12.30-2025~~ Discretion by the supervisor is allowed in granting the time and that vacations may be taken. An EMPLOYEE may accrue up to a maximum of ~~two hundred (200)~~216 hours of vacation

time at any time during the year. The EMPLOYEE will forfeit any amount exceeding ~~200-216~~ accrued hours. Under special circumstances such as a prolonged absence due to a work-related injury or staffing shortages, the City Administrator may waive the forfeiture.

12.4 Vacation may not be used for the first six months of a newly hired EMPLOYEE's probationary period, unless special permission from the Police Chief or designee is obtained.

ARTICLE 13 – SICK LEAVE

13.1 Full-time EMPLOYEES will earn sick leave at the rate of eight (8) hours per full month worked or on paid leave.

13.2 EMPLOYEES may accrue up to one thousand four hundred forty (144) hours of sick leave at full pay.

13.3 Sick leave may be used as provided by law. If time exceeds three(3) consecutive days, the EMPLOYEE will provide their supervisor with a medical verification of illness. EMPLOYEES may use sick leave for the death of a spouse, child or stepchild with approval of their supervisor.

13.4 The documentation provisions referenced in the Earned Sick and Safe Time Act, Minn. Stat. 181.9447, subd. 3(b), shall not apply to paid leave available to an employee for absences from work in excess of the minimum amount required by ESST.

13.5 EMPLOYEES are not eligible to utilize leave for the purposes listed under the Earned Sick and Safe Time Act, Minn. Stat. 181.9447, subd. 1, clause (4), if the employee's preassigned or foreseeable work duties during a public emergency or weather event would require the employee to respond to such an emergency or event unless otherwise authorized by the Chief of designee.

ARTICLE 14 - LEAVE

14.1 City will follow guidelines set out by the Federal Family Medical Leave Act.

14.2 City will allow up to one (1) year medical leave and one (1) year additional leave with approval of the City Council. If an EMPLOYEE chooses to be paid for leave, they shall use vacation time first, then use sick leave.

14.3 The Employer and employee will split the premiums for Minnesota Paid Family Medical Leave, or an equivalent plan, on a 50/50 basis with the employer share payable through payroll deductions pursuant to Minn. Stat. 268B.14.

14.4 EMPLOYEES may utilize accrued paid sick leave to supplement PFML not to exceed 100% of the regular wage of the employee. In the event accrued paid sick leave, if any, is exhausted,

EMPLOYEES may utilize other accrued paid leave to supplement PFML not to exceed 100% of the regular wage of the employee.

ARTICLE 15 – HOLIDAY PAY

15.1 EMPLOYEES shall be paid for ~~eleven (11)~~twelve (12) holidays per calendar year on or before November 30 of each year, plus two (2) Floating Holidays. Floating holidays are determined by length of an EMPLOYEE's shift.

15.2 EMPLOYEES on the yearly work schedule who are scheduled to work on the following holidays will receive an additional half time (1/2) pay.

New Year's Day	Labor Day
Martin Luther King Jr.'s Birthday	Columbus Day
Presidents' Day	Veterans' Day
Memorial Day	Thanksgiving Day
Fourth of July	Christmas Eve Day
<u>Juneteenth</u>	Christmas Day

ARTICLE 16 – WORK SCHEDULES

16.1 The normal work year is two thousand eighty (2,080) hours to be accounted for by each EMPLOYEE through

- a. Hours worked on assigned shifts;
- b. Assigned training;
- c. Authorized leave time.

16.2 Holidays and authorized leave time is to be calculated on the basis of the actual length of time or the assigned shifts

16.3 Training Hours – Training shall be paid at a minimum of two hours.

16.4 Nothing contained in this or any other Article shall be interpreted to be a guarantee of a minimum or maximum number of hours the EMPLOYER may assign EMPLOYEES.

ARTICLE 17 – CALLS TO DUTY

Calls to duty in excess of regular working hours shall be paid at the rate of time and one-half (1-1/2) the EMPLOYEE's regular pay for a minimum of three (3) hours.

17.1 The following shall be the only reasons considered for call to duty

- Adverse weather conditions call out
- Critical incident call out
- Court

ARTICLE 18 – COURT CANCELLATION

If an EMPLOYEE is scheduled to appear in court, the EMPLOYEE shall be paid a minimum of three (3) hours at a time and one-half(1-1/2), or the equivalent of compensatory time, if the court appearance is canceled within twelve hours (12) of the scheduled court appearance.

ARTICLE 19 - OVERTIME

19.1 Overtime for all EMPLOYEES shall be paid at one and one-half (1-1/2) times the EMPLOYEE's regular rate of pay or compensatory time for hours in excess of the regular SCHEDULED SHIFT upon approval of the DEPARTMENT head of the overtime worked.

19.2 EMPLOYEES may accumulate up to a maximum of eighty (80) hours of compensatory time. Unused accrued compensatory time at the end of each calendar year may be carried over to the next calendar year. An EMPLOYEE may convert up to fifty (50) hours of compensatory time to a one-time cash payment, which would be paid along with the holiday paycheck (see Article 15 – Holiday Pay).

19.3 For the purpose of computing overtime compensation, overtime hours worked shall not be pyramided, compounded, or paid twice for the same hours worked.

ARTICLE 20 – UNIFORM ALLOWANCE

20.1 Full-time employees shall receive a lump sum annual payment, ~~of one thousand (\$1,000) dollars-per the schedule below,~~ to use for the purchase of uniforms.

2026 \$1,100

2027 \$1,200

2028 \$1,300

The lump sum payment will be made no later than the last day of March and will be issued in a separate check. Applicable taxes and withholdings will be deducted.

20.2 The city will furnish to full-time EMPLOYEES with the City, full uniform and equipment as listed in Appendix D of this labor agreement. Beginning full-time EMPLOYEES shall not receive the uniform allowance as listed in Article 20.1 until after completion of their probationary period of employment with the city. Said EMPLOYEE after completing their probationary period of employment with the City shall replace any items contained in attachment if the item was

damaged in the line of duty. The city shall clean any items subject to biohazard damage in the line of duty. The city shall provide an initial issue of any newly required uniform items.

20.3 Members of the Special Response Team including SWAT and MFF will receive an additional two hundred (\$200) dollars for uniform allowance.

ARTICLE 21 – FALSE ARREST INSURANCE

All full-time Police Officers shall be insured against the charge of false arrest and the city shall pay the premium in full.

ARTICLE 22 - BONDING

All bonds required for EMPLOYEES in the performance of their duties shall be paid for by the City.

ARTICLE 23 – HEALTH AND DENTAL INSURANCE

23.1 The EMPLOYER will contribute up to a maximum of one thousand four hundred and fifteen (\$1,415) dollars per month for calendar year 2026, one thousand four hundred and forty (\$1,440) dollars per month for calendar year 2027~~one thousand three hundred forty (\$1,340) dollars per month for calendar year 2023, on thousand three hundred sixty five (\$1,365) dollars per month for calendar year 2024, on thousand three hundred ninety (\$1,390) dollars per month for calendar year 2025,~~ on a pro rata basis per qualified EMPLOYEES for group single health and life insurance.

The EMPLOYER will contribute up to a maximum of one thousand five hundred and sixty five (\$1,565) dollars per month for calendar year 2026, one thousand six hundred and fifteen (\$1,615) dollars per month for calendar year 2027~~one thousand four hundred fifteen (\$1,415) dollars per month for calendar year 2023, on thousand four hundred sixty five (\$1,465) dollars per month for calendar year 2024, on thousand five hundred fifteen (\$1,515) dollars per month for calendar year 2025,~~ on a pro rata basis per qualified EMPLOYEE for group single health and life insurance, for coverage tiers including dependent coverage with the exception of single coverage.

A qualified EMPLOYEE is one regularly scheduled to work by the EMPLOYER for twenty (20) hours or more per week.

In the event the health insurance premium increases more than 10% from 2026 to 2027, there shall be a reopener of Section 23.1 of the contract.

For 2028, there shall be a health insurance reopener for Section 23.1 of the contract.

The City will commence a City-wide Labor Management Insurance committee.

23.2 The EMPLOYER will contribute up to a maximum of one hundred seventy-five (\$175) dollars per month for calendar years ~~2023, 2024 and 2025~~ 2026, 2027, and 2028 on a pro rata basis per qualified EMPLOYEE for group dental insurance, including dependent coverage. A qualified EMPLOYEE is one regularly scheduled to work by the EMPLOYER for twenty (20) hours or more per week.

23.3 EMPLOYEES hired prior to January 1, 2010, after thirty (30) years of employment with the City of Forest Lake, and, who retires from the City, may continue in the City's group medical-hospitalization insurance plan, with the same City coverage towards premium as his eligible active EMPLOYEES. The EMPLOYEE'S right for City-contribution towards premium in such group insurance will be discontinued at the end of the month after ten (10) years of retirement. If the EMPLOYEE becomes eligible for Medicare during the ten-year benefit period, the EMPLOYER will contribute toward the cost of a Medicare supplement plan of the EMPLOYEE'S choice, up to the amount of the group health coverage.

23.4 In the event the health insurance provisions of this Agreement fail to meet the requirements of the Affordable Care Act and its related regulations or cause the EMPLOYER to be subject to a penalty, tax or fine, the UNION and the EMPLOYER will meet immediately to bargain over alternative provisions so as comply with the Act and avoid any penalties, taxes or fines for the EMPLOYER.

ARTICLE 24 – HEALTH CARE SAVINGS PLAN

24.1 The EMPLOYER will sponsor a Post-employment Health Care Savings Plan, which will allow EMPLOYEES to utilize pre-tax dollars to help defray the cost of medical expenses and health related insurance premiums after the EMPLOYEE leaves employment.

24.2 Any EMPLOYEE who is eligible to accrue sick and vacation leave benefits will be required to participate in the plan.

24.3 Each EMPLOYEE will be required to deposit ~~the following:~~ 2.5% of their gross wages.

Years of Service	Monthly Contribution
0 through 5	\$80
6 through 10	\$100
11 through 20	\$120
20+	\$120

24.4 Beginning January 1, 2016, the EMPLOYER will contribute twenty-five dollars (\$25) to be deposited into the EMPLOYEE'S Health Care Savings Plan (HCSP) monthly.

ARTICLE 25 – FUNERAL LEAVE

Funeral leave shall be allowed as follows:

Five days in each case of death of:

- EMPLOYEE's parents or stepparents
- EMPLOYEE's spouse, or person regarded as such:
- EMPLOYEE's children, stepchildren, or foster children;

Three days in each case of death of:

- EMPLOYEE's siblings or stepsiblings
- EMPLOYEE's grandparents or step-grandparents;
- EMPLOYEE's grandchildren or step-grandchildren;
- Parents or stepparents of the EMPLOYEE's spouse or person regarded as such;
- Siblings or stepsiblings of the EMPLOYEE's spouse or person regarded as such;

One day in each case of death of:

- EMPLOYEE's aunt, uncle, niece, nephew, including step relations;
- Grandparents or step-grandparents of the EMPLOYEE's spouse or person regarded as such
- Grandchildren or step-grandchildren of the EMPLOYEE's spouse or person regarded as such;

Funeral Leave will be at the EMPLOYEE's regular rate of pay and shall not be counted against the EMPLOYEE's accrued sick leave. Upon approval of the supervisor, the EMPLOYEE may choose to use sick or vacation leave to extend the funeral leave. The City Administrator may require the EMPLOYEE to submit proof of death, such as a funeral card or obituary notice. The City Administrator may determine the length of leave for any case not meeting the above guidelines.

ARTICLE 26 – LIFE INSURANCE

The City shall provide fifty thousand (\$50,000) dollars in life insurance for the EMPLOYEE.

ARTICLE 27 – FIELD TRAINING OFFICER (F.T.O.) COMPENSATION

EMPLOYEES assigned as Field Training Officer(s) by the Chief of Police will receive ~~four dollars~~ (\$4.00)\$7.00 per hour at their hourly pay rate when performing F.T.O. functions and responsibilities.

ARTICLE 28 – POST LICENSE FEE

The city will pay officers Post License fee.

ARTICLE 29 – INVESTIGATORS PAY

29.1 The city will pay investigators, including the narcotics investigator, ~~an additional two hundred twenty five dollars (\$225.00)~~ \$275 per month over the regular rate of pay. An officer continued to be assigned as a General Detective in accordance with the DEPARTMENT policy after the eight (8) year rotation will receive ~~an additional \$250~~ \$300/month over the regular rate of pay for the duration of the continued assignment. This continued assignment will be evaluated on a year-to-year basis by the Detective supervisor.

29.2 Part-time investigators shall be paid an additional \$100/per month if assigned.

29.3 Officers assigned by the Chief of Police as a School Resource Officer will receive ~~an additional one dollar per hour (\$1.00)~~ \$1.50 per hour added to their regular rate of pay for the duration of the assignment as School Resource Officer. The pay premium continues throughout all holiday and summer hours until such time the SRO is no longer assigned as SRO. When an officer is returned to the position of patrol officer, their rate of pay is returned to the applicable patrol officer rate of pay.

ARTICLE 30 – CANINE OFFICER

The EMPLOYER will allow the canine officer the last one-half (1/2) hour of each shift to care for the dog. The officer will be compensated at straight time for this duty. On the officer's day off, the officer will be compensated for one-half (1/2) hours at the overtime rate for care of the dog.

ARTICLE 31 – LONG TERM DISABILITY

The city will reimburse EMPLOYEES for long-term disability insurance premiums.

ARTICLE 32 - EDUCATIONAL

32.1 Educational and conference tuition, fees, per diem and related expenses shall be paid on a case-by-case basis by the EMPLOYER.

32.2 For conferences in the metro area, ten (\$10.00) dollars per day shall be paid to cover mileage, meals and parking. For conferences outside the metro areas, only actual out-of-pocket expenses shall be paid by the EMPLOYER if receipts are provided by the EMPLOYEE to substantiate the claim.

32.3 Non-routine schooling or conference requests shall be referred to the EMPLOYER for prior approval.

32.4 The EMPLOYER will provide tuition/educational assistance in accordance with the policy attached to this Agreement as Appendix B.

ARTICLE 33 – FLEXIBLE SPENDING ACCOUNT

The EMPLOYER shall establish and maintain a voluntary salary reduction program that permits EMPLOYEES to pay medical, dental and day care expenses on a pre-tax basis.

ARTICLE 34 – INJURY ON DUTY LEAVE

34.1 An EMPLOYEE acting within the limits of the authority established by the EMPLOYER, who receives a disabling injury during the performance of assigned official duties performing acts required by law, and wherein it has been determined that the EMPLOYEE has not contributed to the cause of the injury through negligence, judgmental decision, out of wrongful or willful or wanton neglect of duty or other action or inaction, may be granted leave with pay for an y period of disability provided that such leave with pay shall not exceed three hundred sixty (360) hours. Such disabling injury shall be reported to the appointing authority immediately. Request for such leave shall be presented to the EMPLOYER together with supporting documentation including appropriate physician(s) report. Such leave, if granted, shall not be charged to normal sick leave.

34.2 Injury on Duty pay shall be paid at the EMPLOYEE’S current pay rate.

34.3 The provisions of Article 14, Leave, and statutes pertaining to Workers’ Compensation shall apply to any EMPLOYEE who receives Workers’ Compensation benefits while on Injury or Duty Leave. In no case shall the total weekly compensation received by the EMPLOYEE, including leave and Workers’ Compensation benefits exceed the weekly base after tax take-home base pay rate. Any EMPLOYEE, who by reason of illness or injury, receives Workers’ Compensation benefits, may take one of the following courses of action:

- a. Retain the Workers’ Compensation payment and receive from the city a sum equal to the difference between the EMPLOYEE’S normal net pay and the amount of the Workers’ Compensation payment. The first 360 hours of the payment made by the EMPLOYER will be deducted from the Injury on Duty Leave bank established in Section 34.1. Upon exhaustion of the 360 hours of injury on duty pay, the EMPLOYEE may use accrued vacation or sick leave to supplement the Workers’ Compensation payment. Both payments will be subject to State statutes and PERA rules regarding Workers’ Compensation. Generally, the portion of the pay received as the Workers’ Compensation payment is not taxable and is not subject to PERA deductions or benefits. The remaining wages that are received in the form of a paycheck from the EMPLOYER are subject to

income taxes and PERA deductions and benefits. Typically, the EMPLOYEE's service credit for PERA purposes would be maintained throughout the Workers' Compensation period due to the contributions from the EMPLOYEE and EMPLOYER.

- b. Retain the Workers' Compensation payments and utilize the 360 hours of injury on duty pay then decline to receive from the EMPLOYER additional benefits from accrued sick and vacation leave. An EMPLOYEE choosing to utilize this alternative must request and be granted a leave of absence. Service credit for PERA purposes would be impacted.

ARTICLE 35 – PART TIME EMPLOYEE BENEFITS

35.1 Part-time EMPLOYEES regularly scheduled by the EMPLOYER to work less than fourteen hours per week shall not receive benefits under this agreement.

35.2 Part-time EMPLOYEES regularly scheduled by the EMPLOYER to work more than fourteen hours per week shall receive pro rata benefits under this agreement except for benefits under Article 23 – Health and Dental Insurance that shall be governed by the contract between the EMPLOYER and the health insurance carrier.

ARTICLE 36 - WAIVER

36.1 Any and all prior agreements, resolutions, practices, policies, rules and regulations regarding terms and conditions of employment, to the extent inconsistent with the provisions of this agreement are hereby superseded.

36.2 The Parties mutually acknowledge that during the negotiations, which resulted in this agreement, each had the unlimited right and opportunity to make demands and proposals with respect to any term or condition of employment not removed by law from bargaining. All agreements and understandings arrived at by the parties are set forth in writing in this agreement. The EMPLOYER and the UNION each voluntarily and unqualifiedly waives the right to meet and negotiate regarding any and all terms and conditions of employment referred to or covered in this agreement or with respect to any term or condition of employment not specifically referred to or covered in this agreement, even though such terms or conditions may not have been within the knowledge or contemplation of either or both parties at the time this contract was negotiated or executed.

ARTICLE 37 – DURATION

This agreement shall remain in full force and effect from January 1, ~~2023-2026~~ through December 31, ~~2025~~2028. Either party desiring a change or modifications of the agreement shall

provide written notice of such desire to change at least sixty (60) days prior to expiration of the agreement.

FOR THE CITY OF FOREST LAKE:

Mayor

Date

City Administrator

Date

FOR LAW ENFORCEMENT LABOR SERVICES, INC.

Date

Date

Date



APPENDIX A - ~~2025-2025~~ - WAGE SCHEDULE

Lateral Entry/ the Employer will generally attempt to hire new EMPLOYEES at the probationary officer Level of the wage schedule unless experience or qualifications indicate a different placement on the schedule. The employer may start an employee at any level within the salary range that the employer determines appropriate.

New officers will not be given lateral seniority or vacation/sick leave rights. New officers will not be accelerated on the longevity pay steps.

Effective January 1, 2026, the Police Officer position will be assigned "Grade 115" in the city's new 6-step pay scale. Wages and steps for Grade 115 in 2026 are as follows:

	<u>1</u>	<u>2</u>	<u>3</u>	<u>4</u>	<u>5</u>	<u>6</u>
<u>115</u>	<u>\$44.61</u>	<u>\$46.39</u>	<u>\$48.25</u>	<u>\$50.18</u>	<u>\$52.19</u>	<u>\$54.28</u>

- a) EMPLOYEES will be placed in the applicable grade and on their same step.
- b) EMPLOYEES who are eligible for a step increase shall then receive their step increase on January 1, 2026.
- c) Effective January 1, 2027 there shall be a 3.0% general wage increase.
- d) EMPLOYEES who are eligible for a step increase shall then receive their step increase on January 1, 2027.
- e) Said implementation is outlined on the attached Addendum B. In the event that there is a rounding difference between the attached and payroll, payroll shall govern.

Longevity:

At Year 10 2.0% on top of base wage

At Year 15 Additional 2.0% on top of base wage. (This shall be calculated by applying a 2.0% increase for the At Year 10 Longevity and an additional 2.0% increase for the At Year 15 Longevity).

- f) Effective January 1, 2028 there shall be a 3.0% general wage increase.
- g) EMPLOYEES who are eligible for a step increase shall then receive their step increase on January 1, 2028.

APPENDIX B - TUITION REIMBURSEMENT/EDUCATIONAL INCENTIVE

The EMPLOYER encourages its EMPLOYEES to enroll in job related educational programs and may provide support through tuition reimbursement. This does not include reimbursement for textbooks or study materials.

Requirements: In order for a class to qualify for reimbursement, the following conditions must be met:

- The class/course must be job related;
- The class/course must be taken from an accredited institution of higher learning or vocational-technical school;
- The class/course must be approved by the City Administer prior to enrolling;
- The Employee must receive a passing grade (C or better) in order to receive reimbursement;
- The Employee must complete a Tuition Reimbursement form and provide a brief course outline;
- After the class/course has been completed, the Employee must provide a photocopy of the grade form and the original receipt for tuition;
- The Employee must remain with the City for one year after completing the class/course, or reimburse the City for the total cost of any class taken in the previous one-year period.
- The Employee must notify the City by July 1st of the prior year.

Forms: Tuition Reimbursement forms are available from the Finance Director. A photocopy of the completed Tuition Reimbursement form will be placed the Employee's personnel file.

Limit: No employee may receive in excess of \$2,000 tuition reimbursement in any one calendar year. The City Council may waive this limitation in unusual circumstances where it is determined that there is a justifiable City need for an Employee to take additional schooling.

APPENDIX C – UNIFORM LIST

1. 3 pair Navy Blue Pants
2. 3 pair Navy Blue Long Sleeve Shirts
3. 3 pair Navy Blue Short Sleeve Shirts
4. 1 Dress Hat with Rain Cover
5. 1 winter Stocking Hat with gold "POLICE" in front
6. 1 Bullet Proof Vest
7. 2 Shirt Badges
8. 1 Hat Badge
9. 1 Winter Jacket or cash equivalent towards Leather.
10. 1 pair of Gloves
11. 1 Tie Tac
12. 1 Navy blue tie
13. 1 pair of Black Boots or Black Shoes
14. 1 Rain Coat
15. 1 Department Issued Weapon
16. 3 Department issued Magazines for Duty Weapon, with gun lock
17. 1 Inner hook & loop closure Belt or Velcro belt
18. 1 Outer Belt
19. 1 holster for duty weapon
20. 1 magazine holder
21. 1 Key holder
22. 1 Chemical spray
23. 1 Chemical Spray Holder
24. 2 sets of Handcuffs
25. 1 handcuff case
26. 1 Handcuff Key
27. 1 Flashlight
28. 1 Flashlight Holder
29. 1 rubber Glove Holder
30. 4 Belt Keepers Gold, Black or Hidden Snap
31. 1 Expandable Baton (16"-26")
32. 1 Expandable Baton Holder
33. 1 Brass Buckle (optional)
34. 1 Gear / Squad Bag
35. 1 radio holder
36. 1 tourniquet
37. 1 tourniquet holder
38. 1 reflective vest

STAFF REPORT



MEETING DATE: January 12, 2026

TO: Honorable Mayor Roberts and Members of the City Council

STAFF ORIGINATOR: Jolleen Chaika – Assistant City Administrator

AGENDA ITEM: Memorandum of Agreement with AFSCME

INTRODUCTION:

The City and AFSCME Council No. 5 are currently parties to a Collective Bargaining Agreement (CBA) in effect through December 31, 2027. The CBA includes all positions currently covered under the CBA. As the City just hired a new Deputy City Clerk, and this position is union-eligible, a Memorandum of Agreement has been drafted to include the position with the unit.

RECOMMENDATION:

Staff recommends Council **move to approve the Memorandum of Agreement between the City and AFSCME regarding the inclusion of the Deputy City Clerk into the CBA for AFSCME Council 5, Local 517.**

ATTACHMENTS:

Memorandum of Agreement: Deputy City Clerk

MEMORANDUM OF AGREEMENT

This Memorandum of Agreement is entered into between the City of Forest Lake (hereafter the "City") and American Federation of State, County and Municipal Employees, Council 5, Local 517 (hereafter the "Union").

WHEREAS, the City and the Union are parties to a collective bargaining agreement effective January 1, 2025 through December 31, 2027; and,

WHEREAS, the current Union contract does not include the position of Deputy City Clerk; and,

WHEREAS, the Deputy City Clerk is a full-time, non-exempt and benefits eligible position budgeted for 40 hours per work week; and,

WHEREAS, the City has created, recruited, and hired for the position of Deputy City Clerk.

NOW THEREFORE, the City and the Union agree as follows:

1. The newly created part time position of Deputy City Clerk will be included in the Collective Bargaining Agreement effective January 1, 2026 through December 31, 2027.
2. The Deputy City Clerk is graded at Grade 100 on the 2026 City Salary schedule and will be paid as follows:

100	\$35.42	\$36.84	\$38.31	\$39.84	\$41.43	\$43.09
-----	---------	---------	---------	---------	---------	---------

3. This Memorandum of Agreement will be in effect until December 31, 2027 or the successor contract is negotiated.
4. This Memorandum of Agreement represents the complete and total agreement between the parties regarding this matter.

IN WITNESS WHEREOF, the parties have caused this Memorandum of Agreement to be executed this ____ day of _____, 2026.

CITY OF FOREST LAKE

American Federation of State, County and Municipal Employees, Council 5, Local 517

Business Representative

Date

Date



STAFF REPORT

MEETING DATE: January 12, 2026

TO: Honorable Mayor Roberts and Members of the City Council

STAFF ORIGINATOR: Jolleen Chaika, Assistant City Administrator

AGENDA ITEM: Approval of Deputy Fire Chief Job Description and Recruitment Authorization

INTRODUCTION:

During both the 2025 and 2026 budget processes, it was identified that the scope and complexity of operations within the Fire Department have continued to expand. Increased administrative demands, regulatory requirements, personnel management responsibilities, and service delivery expectations have exceeded the capacity of the current staffing model. In response, Fire Chief Newman has worked closely with Administration to evaluate organizational needs and develop a sustainable leadership structure that supports operational readiness, regulatory compliance, and long-term departmental planning.

ANALYSIS:

Attached for the Council's review and consideration is a proposed job description for a new Deputy Fire Chief position. The Deputy Fire Chief will serve as the department's second-in-command and a key member of the Fire Department's leadership team, reporting directly to the Fire Chief. This position is designed to provide strategic, administrative, and operational oversight across a broad range of departmental functions, including fire suppression, emergency medical services, training, personnel management, and community risk reduction initiatives

Under the proposed structure, the Deputy Fire Chief will assist the Fire Chief in planning, organizing, and directing departmental operations; developing and implementing policies, standard operating guidelines, and long-range strategic plans; and ensuring compliance with applicable OSHA, NFPA, state, and federal regulations. The position will also play a significant role in supervising personnel, overseeing training and professional development, supporting labor relations, managing assigned budgets and administrative functions, and coordinating interagency and mutual-aid efforts

In the absence of the Fire Chief, the Deputy Fire Chief will be authorized to assume full command of the department and represent the City and Fire Department at public meetings, regional collaborations, and community engagement activities. This role is intended to strengthen continuity of leadership, enhance operational oversight, and ensure consistent management presence during both routine operations and major or complex incidents.

The Deputy Fire Chief position is proposed at Grade 140 on the City's newly established Wage

Scale. This classification aligns with comparable deputy or assistant chief roles in similarly situated metro-area municipalities and reflects the command-level responsibilities, supervisory authority, and professional qualifications required for the position.

If approved, staff suggests initiating recruitment efforts with an internal process initially to open this position up to current fire fighter staff who may be well-qualified for the position. Should a candidate not be selected after an internal process, staff would then proceed with an external recruitment process.

RECOMMENDATION:

Staff recommends that the City Council approve the Deputy Fire Chief job description as presented and authorize staff to proceed with recruitment efforts as outlined above for this position.

ATTACHMENTS:

Deputy Fire Chief Job Description



JOB DESCRIPTION

JOB TITLE:	Deputy Fire Chief	
CLASSIFICATION:	Full-Time/Union	FLSA: Exempt
DEPARTMENT:	Fire	
SUPERVISOR:	Fire Chief	

SUMMARY

Under the general direction of the Fire Chief, the Deputy Fire Chief serves as the second-in-command and a key member of the department's leadership team. This position provides strategic, administrative, and operational oversight in planning, organizing, and directing a wide range of fire and emergency services functions, including fire suppression, emergency medical services, training, and community risk reduction initiatives.

The Deputy Fire Chief is responsible for helping to develop and implement department policies, goals, and objectives that reduce loss of life, property, and community impact from fire and other hazards. Work involves applying comprehensive knowledge of fire science, hazardous materials, building construction, emergency medical practices, and risk-reduction strategies.

In the absence of the Fire Chief, the Deputy Fire Chief may assume full command of the department, representing the organization at public meetings, interagency collaborations, and community engagement events. This role requires strong leadership, sound judgment, and the ability to guide personnel, programs, and operational priorities in support of the department's mission.

ESSENTIAL DUTIES

Leadership & Administration

- Assists the Fire Chief in planning, directing, and evaluating all department operations, programs, and services to ensure effective emergency response, regulatory compliance, and service delivery.
- Participates in developing departmental goals, policies, standard operating guidelines (SOGs), and long-range strategic plans.
- Provides leadership, guidance, and mentorship to command staff, company officers, and line personnel, fostering professional development and operational readiness.
- Oversees assigned divisions such as Operations, Training, EMS, Administration, or Community Risk Reduction, depending on organizational needs.
- Manages administrative functions related to assigned areas, including budgeting, purchasing, reporting, and performance measurement, and record keeping.
- Acts as Fire Chief in the Chief's absence, assuming full authority and responsibility for departmental operations and representation.

Operational Management

- Directs and supports daily operational readiness, staffing, resource allocation, and deployment of personnel and equipment.
- Responds to major or complex incidents in a command or support role, providing incident management in accordance with NIMS/ICS.
- Reviews incident reports, analyzes operational data, and recommends improvements for efficiency and safety.
- Ensures proper maintenance, testing, and replacement of apparatus, equipment, and protective gear.

Training & Professional Development

- Oversees or coordinates the development, implementation, and evaluation of training programs for firefighting, EMS, technical rescue, and specialty disciplines.
- Ensures compliance with federal, state, and local training standards, certifications, and continuing education requirements.
- Promotes professional development, succession planning, and leadership development initiatives.

Community Risk Reduction / Fire Prevention

- Assists in planning and implementing community risk reduction (CRR) strategies, fire prevention programs, and public education initiatives.
- Works collaboratively with building officials, inspectors, and investigators regarding code enforcement, plan review, and fire cause determination.
- Supports the development of risk assessment strategies that align with departmental and community needs.

Personnel Management

- Provides day-to-day supervision of paid on-call fire personnel, including work assignments, staffing coverage, scheduling, and approval of training hours, responses, and overtime as applicable.
- Participates in recruitment, selection, hiring, promotion, and disciplinary processes; coordinates onboarding, orientation, and completion of probationary evaluations.
- Conducts performance evaluations, coaching, training oversight, and career development for assigned personnel; approves time records, response documentation, and leave requests in accordance with department and City policy.
- Recommends promotions, commendations, and disciplinary actions; administers performance improvement plans and formal corrective actions consistent with departmental and City policies and applicable laws.
- Assists in managing labor relations by ensuring adherence to City policies, departmental rules, and applicable state and federal employment laws.

- Exercises independent judgment in personnel and operational matters and ensures compliance with organizational standards, safety requirements, and professional fire service practices.

Interagency & Community Relations

- Represents the Fire Department in meetings with City officials, partner agencies, regional fire service organizations, and community groups.
- Serves as a liaison with mutual-aid partners and participates in regional planning efforts.
- Helps maintain effective communication and positive relationships with the public, stakeholders, and media as appropriate.

Regulatory Compliance & Safety

- Ensures departmental compliance with OSHA, NFPA, state fire codes, EMS regulations, and other applicable standards.
- Supports development and oversight of health and safety programs, including risk management and after-action review processes.
- Monitors evolving laws, regulations, and best practices impacting the fire service.

OTHER DUTIES

Performs additional duties and related tasks as required, or as directed by the Fire Chief.

MINIMUM QUALIFICATIONS

Education and Experience

- Associate's degree in Fire Science, Emergency Management, Public Administration, Business Administration, or a closely related field.
- Seven (7) years of progressively responsible fire service experience, including a minimum of three (3) years in a supervisory, command-level, or administrative leadership role.
- Firefighter I, Firefighter II, and Haz-Mat Operations
- Emergency Medical Responder (EMR) certification or higher as required by the department.
- Incident Command System (ICS) and National Incident Management System (NIMS) training appropriate for command-level responsibilities.
- Minnesota State Firefighter License (or ability to obtain within the timeframe established by the department).
- Possession of a valid state driver's license and the ability to meet department driving standards.

Knowledge, Skills, and Abilities:

- Principles, practices, and modern methods of fire suppression, rescue operations, and emergency medical response.
- Incident Command System (ICS), NIMS, and emergency management practices used in multi-agency operations.
- Fire prevention, inspection principles, community risk reduction strategies, and code enforcement fundamentals.
- Department administration, including budgeting, personnel management, training program development, and strategic planning.

- Applicable federal, state, and local laws, regulations, standards, and best practices (including OSHA and NFPA guidelines).
- Building construction, fire behavior, hazardous materials awareness, and emergency scene safety.
- Effective leadership techniques, organizational management, and team development principles.
- Leading, motivating, and developing staff to achieve department goals and maintain high performance standards.
- Analyzing operational needs, identifying issues, and implementing improvements in procedures, training, and resource allocation.
- Managing complex incidents using sound judgment, situational awareness, and effective command presence.
- Communicating clearly and professionally in both verbal and written formats, including reports, presentations, and public interactions.
- Building collaborative working relationships with internal staff, partner agencies, city departments, and the community.
- Managing multiple priorities and making timely decisions in both routine and high-stress situations.
- Provide leadership and direction in a command-level capacity, including during major incidents and emergency situations.
- Interpret and apply policies, procedures, regulations, and technical information relevant to fire service operations.
- Plan, organize, and manage programs, personnel, and resources efficiently and effectively.
- Evaluate staff performance, provide constructive feedback, and engage in coaching and mentoring.
- Represent the department professionally in meetings, community events, and interagency collaborations.
- Maintain confidentiality, exercise discretion, and demonstrate high ethical and professional standards.
- Work irregular hours, respond to emergency call-backs, and operate effectively under stress or rapidly changing conditions.

PHYSICAL DEMANDS

- Requires the ability to perform essential job functions while wearing full personal protective equipment (PPE), including self-contained breathing apparatus (SCBA), in environments that may involve extreme heat, limited visibility, rapidly changing conditions, and hazardous atmospheres.
- Must be capable of performing strenuous physical activities such as climbing ladders, advancing hoselines, operating tools, dragging or carrying equipment, and assisting in victim rescue operations.
- Requires the ability to lift, carry, push, or pull objects and equipment weighing up to 100 pounds, and to perform tasks requiring balance, coordination, flexibility, and muscular endurance.
- Must be able to execute rapid movements, such as quickly transitioning from sedentary administrative tasks to emergency response, including running short distances, kneeling, crawling, and navigating uneven or unstable surfaces.

- Requires adequate cardiovascular fitness to perform extended activities under physically demanding and stressful conditions, including functioning in high temperatures and wearing heavy protective gear.
- Must possess sufficient vision, with or without corrective lenses, to read gauges, observe hazards, evaluate scenes, and perform critical tasks; includes depth perception, peripheral vision, and color differentiation.
- Requires adequate hearing acuity to detect alarms, radio communications, verbal instructions, and environmental hazards amid high noise levels.
- Must be able to communicate effectively under stress, including issuing clear, concise verbal commands during emergency operations.
- Requires the ability to work in confined spaces, at heights, in dark environments, and in close proximity to fire, smoke, electrical hazards, chemicals, and other dangerous conditions.
- Must tolerate physical and mental stressors inherent to emergency response, including exposure to traumatic incidents, long-duration operations, fatigue, and irregular sleep cycles.
- Requires the ability to safely operate vehicles, equipment, and communication devices under both routine and emergency conditions.

WORKING ENVIRONMENT

- Work is performed in a combination of office, station, training, and emergency response environments.
- Exposure to extreme weather conditions including heat, cold, rain, snow, wind, and other environmental factors during outdoor activities and emergency operations.
- Frequent exposure to hazardous conditions such as fire, smoke, toxic chemicals, electrical hazards, unstable structures, bodily fluids, and other dangerous situations inherent to fire and emergency response work.
- May work in confined spaces, at significant heights, on slippery or uneven surfaces, or in areas with limited visibility.
- Work may involve exposure to loud noises, flashing lights, and other sensory stressors associated with alarms, apparatus, power tools, and emergency scenes.
- Subject to occupational risks consistent with fireground operations, including falling debris, structural collapse, and rapidly changing incident conditions.
- Requires the ability to remain on-call or respond to emergencies outside normal business hours, including evenings, weekends, and holidays.
- Work hours may be extended during emergency incidents, large-scale events, special assignments, or staffing needs.
- Frequent interruptions, deadlines, and high-stress situations requiring the ability to remain focused and make critical decisions.
- Regular interaction with the public, city officials, partner agencies, and staff, requiring professionalism, tact, and effective communication.
- May be required to attend meetings, trainings, and community events during non-standard hours.
- Use of computers and office equipment for extended periods is required for administrative tasks, data review, and reporting.

STAFF REPORT



MEETING DATE: January 12, 2026
TO: Honorable Mayor Roberts and Members of the City Council
STAFF ORIGINATOR: Jolleen Chaika, Assistant City Administrator
AGENDA ITEM: Hiring Recommendation: Police Administrative Assistant

INTRODUCTION:

During the 2026 Budget approval process, the City Council authorized an additional Police Administrative Assistant position to support the functions of the Forest Lake Police Department. As the City had recruited for this position in 2025, a list of qualified candidates was maintained on an eligibility list for the position of Police Administrative Assistant.

ANALYSIS:

Jody Boyd was one of over seventy applicants for the open position in 2025. Ms. Boyd completed the police administrative assistant hiring process, which included an initial interview panel with non-sworn police personnel and sworn police personnel, and then a final interview with the Captain and Chief of Police. Since the opening of the newly created additional position, the eligibility list was reviewed and Ms. Boyd was contacted and was offered and accepted a conditional offer of employment with the Forest Lake Police Department, pending passing a background investigation.

Ms. Boyd has over 10 years of experience serving previously with the New Brighton Police Department and, currently, with the Lino Lakes Police Department.

The conditional offer proposes appointment as a Police Administrative Assistant at Grade 95, Step 4 of the 2026 Salary Scale. The offer also includes a starting bank of vacation time at 20 hours and sick time at 20 hours.

RECOMMENDATION:

Staff recommends Council **move to approve the conditional offer of employment to Jody Boyd for the position of Police Administrative Assistant.**

STAFF REPORT



MEETING DATE: January 12, 2026

TO: Honorable Mayor Roberts and Members of the City Council

STAFF ORIGINATOR: Jolleen Chaika, Assistant City Administrator

AGENDA ITEM: Fee Waiver Request

INTRODUCTION:

The Rotary Club of Forest Lake is hosting the annual Winter Plunge fundraiser on Saturday, February 28 Forest Lake/Lake 1. A fee waiver has been requested. Because the fee schedule requires a fee for tent and event permits, Council approval is required to waive fees.

RECOMMENDATION:

Staff recommends that Council approve waiver of City fees associated with the 2026 Winter Plunge event.

ATTACHMENTS:

Rotary Club Letter



January 2, 2026

Dear Forest Lake City Council members:

The Rotary Club of Forest Lake is planning to have our annual Winter Plunge on February 28, 2026 this year. The Winter Plunge is a fundraiser that allows participants to form teams to raise funds for their favorite non-profit entity by "plunging" into the lake. Our club is aware that many of our local non-profit organizations have suffered financially and it is vitally important to the Club that we support these organizations and assist with fundraising efforts through the Winter Plunge.

The Rotary Club of Forest Lake is a 501c4, which means we are exempt from federal and state taxes. In light of that, I would like to request that you consider waiving our permit fees for the event. By waiving permit fees, you enable our Club to give more back to the non-profits that participate in the Winter Plunge by lessening our expenses to put on the event. Thank you for your consideration in this matter.

We greatly appreciate the City staff and Council for all the assistance you have provided for this event. We are thankful and proud to work in such a great community.

Sincerely,

Angela Comstock

Executive Secretary/Director

Ph:612-860-9352

a.comstock3210@gmail.com

STAFF REPORT



MEETING DATE: January 12, 2026
STAFF ORIGINATOR: Mark Statz – City Administrator
AGENDA ITEM: Police Chief Resignation

INTRODUCTION: After a long and successful career, Police Chief Rick Peterson has tendered his resignation, and his last day of employment will be April 3, 2026.

ANALYSIS:

As a best practice, the League of Minnesota Cities recommends that city councils in Plan A statutory cities formally accept resignations. Additionally, if the intent is to replace the resigning employee, a vacancy at that position should be declared as well. Severance and other termination pay will be determined in accordance with the city's adopted Personnel Policy and/or applicable collective bargaining contracts.

The Personnel Committee has invited members of the city's police department to engage with them in leadership discussions to gauge interest in the position among our current staff. After these conversations, the committee will present a hiring process strategy to the City Council for consideration at its next meeting.

RECOMMENDATION: Motion to recommend that the City Council accept the resignation of Police Chief Rick Peterson, with the last day of employment being April 3, 2026 and declare a vacancy at the position.

ATTACHMENTS: None.

STAFF REPORT



MEETING DATE: January 12, 2026
STAFF ORIGINATOR: Mark Statz – City Administrator
AGENDA ITEM: Accounting Manager Resignation

INTRODUCTION: Staff is in receipt of the resignation of Accounting Manager, Kim Carlson, effective Friday January 9, 2026.

ANALYSIS:

As a best practice, the League of Minnesota Cities recommends that city councils in Plan A statutory cities formally accept resignations. Severance and other termination pay will be determined in accordance with the city's adopted Personnel Policy and/or applicable collective bargaining contracts.

At this time, leadership would like to forego declaring an opening and reposting the job in order to re-examine the Accounting Manager position. A formal position description for the reimagined position will be brought forward in the near future for consideration. Once the new role is better defined and can be scored for placement on the wage matrix, we will ask Council for authorization to advertise for the opening.

RECOMMENDATION: Motion to accept the resignation of Accounting Manager, Kim Carlson.

ATTACHMENTS: None.



Office of Engineering
1408 Lake Street South
Forest Lake, MN 55025
www.ci.forest-lake.mn.us

January 2, 2026

Honorable Mayor and City Council
City of Forest Lake
1408 Lake Street South
Forest Lake, MN 55025

RE: Contractor's Request for Payment No. 1
Eureka Avenue Improvements Project

Dear Mayor and Council:

We recommend the council approve Contractor's Request for Payment No. 1 and pay \$52,922.36 to Forest Lake Contracting, Inc. for the services and Materials on Hand they provided on the above referenced project. This estimate also includes 5% retainage.

The contractor had mobilized equipment and traffic control to the site, salvaged the chain link fence and installed the temporary fence, and started to install the temporary erosion control devices. This work was performed prior to the decision being made to suspend the project for the winter due to cold weather.

Please call me at 612-597-7140 if you have any questions or concerns regarding this Contractor's payment request.

Sincerely,

Ryan J. Goodman, P.E.
City Engineer

Enclosures: Contractor's Request for Payment No. 1

Contractor's Application for Payment

Owner: <u>City of Forest Lake</u>	Owner's Project No.: _____
Engineer: <u>Bolton & Menk, Inc.</u>	Engineer's Project No.: <u>ON1.131631</u>
Contractor: <u>Forest Lake Contracting, Inc.</u>	Agency's Project No.: <u>SAP 214-594-002</u>
Project: <u>Eureka Avenue Improvements</u>	
Contract: _____	
Application No.: <u>1</u>	Application Date: <u>12/31/2025</u>
Application Period: From <u>11/17/2025</u> to <u>12/19/2025</u>	

1. Original Contract Price		\$	3,387,743.50
2. Net change by Change Orders		\$	-
3. Current Contract Price (Line 1 + Line 2)		\$	3,387,743.50
4. Total Work completed and materials stored to date (Sum of Column G Lump Sum Total and Column J Unit Price Total)		\$	55,707.75
5. Retainage			
a. <u>5%</u> X <u>\$ 50,847.75</u> Work Completed		\$	2,542.39
b. <u>5%</u> X <u>\$ 4,860.00</u> Stored Materials		\$	243.00
c. Total Retainage (Line 5.a + Line 5.b)		\$	2,785.39
6. Amount eligible to date (Line 4 - Line 5.c)		\$	52,922.36
7. Less previous payments			
8. Amount due this application		\$	52,922.36
9. Balance to finish, including retainage (Line 3 - Line 4)		\$	3,332,035.75

Contractor's Certification

The undersigned Contractor certifies, to the best of its knowledge, the following:

(1) All previous progress payments received from Owner on account of Work done under the Contract have been applied on account to discharge Contractor's legitimate obligations incurred in connection with the Work covered by prior Applications for Payment;

(2) Title to all Work, materials and equipment incorporated in said Work, or otherwise listed in or covered by this Application for Payment, will pass to Owner at time of payment free and clear of all liens, security interests, and encumbrances (except such as are covered by a bond acceptable to Owner indemnifying Owner against any such liens, security interest, or encumbrances); and

(3) All the Work covered by this Application for Payment is in accordance with the Contract Documents and is not defective.

Contractor: Forest Lake Contracting, Inc.

Signature: _____ **Date:** _____

Name: _____ **Title:** _____

Recommended by Bolton & Menk, Inc.	Approved by City of Forest Lake
By: _____	By: _____
Name: _____	Name: _____
Title: _____	Title: _____
Date: _____	Date: _____

Progress Estimate - Unit Price Work

Contractor's Application for Payment

Owner:	City of Forest Lake	Owner's Project No.:	
Engineer:	Bolton & Menk, Inc.	Engineer's Project No.:	0N1.131631
Contractor:	Forest Lake Contracting, Inc.	Agency's Project No.:	SAP 214-594-002
Project:	Eureka Avenue Improvements		
Contract:			

Application No.: 1 Application Period: From 11/17/25 to 12/19/25 Application Date: 12/31/25

A	B	C	D	E	F	F1		F2		G		H		I	J	K	L
						Quantity Previous Estimate	Value Previous Estimate	Estimated Quantity Incorporated in the Work	Value of Work Completed to Date (E X G) (\$)	Materials Currently Stored (not in G) (\$)	Work Completed and Materials Stored to Date (H + I) (\$)	% of Value of Item (J / F) (%)	Balance to Finish (F - J) (\$)				
Bid Item No.	Description	Item Quantity	Units	Unit Price (\$)	Value of Bid Item (C X E) (\$)	Contract Information		Previous Estimate		Work Completed		Materials Currently Stored (not in G) (\$)	Work Completed and Materials Stored to Date (H + I) (\$)	% of Value of Item (J / F) (%)	Balance to Finish (F - J) (\$)		
						Quantity	Value	Quantity	Value	Quantity	Value						
BASE BID																	
1	MOBILIZATION	1.00	LUMP SUM	179,000.00	179,000.00			-		0.10	17,900.00		17,900.00	10%	161,100.00		
2	CLEARING & GRUBBING	1.00	LUMP SUM	4,460.00	4,460.00			-		0.25	1,115.00		1,115.00	25%	3,345.00		
3	REMOVE CONCRETE APRON	1.00	EACH	350.00	350.00			-		-	-		-	-	350.00		
4	REMOVE SIGN TYPE C	32.00	EACH	25.00	800.00			-		-	-		-	-	800.00		
5	SALVAGE CONCRETE APRON	2.00	EACH	500.00	1,000.00			-		-	-		-	-	1,000.00		
6	SALVAGE SIGN TYPE C	2.00	EACH	25.00	50.00			-		-	-		-	-	50.00		
7	SAWING BITUMINOUS PAVEMENT (FULL DEPTH)	115.00	LIN FT	5.00	575.00			-		-	-		-	-	575.00		
8	REMOVE PIPE CULVERTS	127.00	LIN FT	12.00	1,524.00			-		-	-		-	-	1,524.00		
9	SALVAGE CHAIN LINK FENCE	1,720.00	LIN FT	5.00	8,600.00			-		1,724.00	8,620.00		8,620.00	100%	(20.00)		
10	REMOVE CURB & GUTTER	25.00	LIN FT	10.00	250.00			-		-	-		-	-	250.00		
11	REMOVE BITUMINOUS PAVEMENT	15,550.00	SQ YD	2.50	38,875.00			-		-	-		-	-	38,875.00		
12	ABANDON PIPE SEWER - FORCEMAIN	3,440.00	LIN FT	5.00	17,200.00			-		-	-		-	-	17,200.00		
13	EXCAVATION - COMMON (EV) (P)	15,356.00	CU YD	16.00	245,696.00			-		-	-		-	-	245,696.00		
14	EXCAVATION - SUBGRADE (EV)	2,100.00	CU YD	25.00	52,500.00			-		-	-		-	-	52,500.00		
15	GRANULAR EMBANKMENT (CV) (P)	6,200.00	CU YD	30.00	186,000.00			-		-	-		-	-	186,000.00		
16	SELECT GRANULAR EMBANKMENT (CV)	13,600.00	CU YD	19.00	258,400.00			-		-	-		-	-	258,400.00		
17	COMMON EMBANKMENT (CV) (P)	4,013.00	CU YD	8.00	32,104.00			-		-	-		-	-	32,104.00		
18	DEWATERING	1.00	LUMP SUM	2,500.00	2,500.00			-		-	-		-	-	2,500.00		
19	FILTRATION BASIN	1.00	LUMP SUM	29,000.00	29,000.00			-		-	-		-	-	29,000.00		
20	PIEZOMETER	3.00	EACH	9,000.00	27,000.00			-		-	-	4,860.00	4,860.00	18%	22,140.00		
21	SETTLEMENT PLATES	7.00	EACH	1,800.00	12,600.00			-		-	-		-	-	12,600.00		
22	CONSTRUCT DRAINAGE DITCH	450.00	LIN FT	14.00	6,300.00			-		-	-		-	-	6,300.00		
23	GEOTEXTILE FABRIC TYPE 5	20,750.00	SQ YD	3.00	62,250.00			-		-	-		-	-	62,250.00		
24	GEOTEXTILE FABRIC TYPE 12	9,185.00	SQ YD	9.00	82,665.00			-		-	-		-	-	82,665.00		
25	SUBGRADE PREPARATION	20,750.00	SQ YD	1.20	24,900.00			-		-	-		-	-	24,900.00		
26	AGGREGATE SURFACING CLASS 2	325.00	TON	66.00	21,450.00			-		-	-		-	-	21,450.00		
27	STREET SWEEPER (WITH PICKUP BROOM AND OPERATOR)	40.00	HOUR	0.01	0.40			-		-	-		-	-	0.40		
28	WATER (FOR DUST CONTROL)	40.00	MGAL	45.00	1,800.00			-		-	-		-	-	1,800.00		
29	AGGREGATE BASE CLASS 5	15,290.00	TON	19.00	290,510.00			-		-	-		-	-	290,510.00		
30	BITUMINOUS MATERIAL FOR TACK COAT	1,300.00	GAL	4.50	5,850.00			-		-	-		-	-	5,850.00		
31	TYPE SP 9.5 WEARING COURSE MIXTURE (2,B)	1,000.00	TON	89.00	89,000.00			-		-	-		-	-	89,000.00		
32	TYPE SP 9.5 WEARING COURSE MIXTURE (3,C)	1,665.00	TON	99.00	164,835.00			-		-	-		-	-	164,835.00		
33	TYPE SP 12.5 WEARING COURSE MIXTURE (3,C)	2,775.00	TON	83.00	230,325.00			-		-	-		-	-	230,325.00		
34	INSTALL STRUCTURE	1.00	EACH	13,000.00	13,000.00			-		-	-		-	-	13,000.00		
35	CONCRETE FOOTING	1.00	EACH	35,000.00	35,000.00			-		-	-		-	-	35,000.00		
36	LANDSCAPE OVERLOOK 1	1.00	LUMP SUM	12,000.00	12,000.00			-		-	-		-	-	12,000.00		
37	LANDSCAPE OVERLOOK 2	1.00	LUMP SUM	10,000.00	10,000.00			-		-	-		-	-	10,000.00		
38	LANDSCAPE OVERLOOK 3	1.00	LUMP SUM	13,000.00	13,000.00			-		-	-		-	-	13,000.00		
39	LANDSCAPE OVERLOOK 4	1.00	LUMP SUM	6,800.00	6,800.00			-		-	-		-	-	6,800.00		
40	LANDSCAPE OVERLOOK 5	1.00	LUMP SUM	14,000.00	14,000.00			-		-	-		-	-	14,000.00		
41	MODULAR BLOCK RETAINING WALL	1,100.00	SQ FT	118.00	129,800.00			-		-	-		-	-	129,800.00		
42	COARSE AGGREGATE BEDDING	230.00	LIN FT	21.00	4,830.00			-		-	-		-	-	4,830.00		
43	PIPE RAILING DESIGN SPECIAL	350.00	LIN FT	242.00	84,700.00			-		-	-		-	-	84,700.00		
44	INSTALL CONCRETE APRON	2.00	EACH	1,000.00	2,000.00			-		-	-		-	-	2,000.00		
45	15" RC PIPE APRON	6.00	EACH	2,000.00	12,000.00			-		-	-		-	-	12,000.00		
46	60" PIPE APRON	2.00	EACH	7,800.00	15,600.00			-		-	-		-	-	15,600.00		
47	TRASH GUARD FOR 30" PIPE APRON	2.00	EACH	3,200.00	6,400.00			-		-	-		-	-	6,400.00		
48	CLEAN PIPE CULVERT	140.00	LIN FT	8.00	1,120.00			-		-	-		-	-	1,120.00		
49	4" PRECAST CONCRETE HEADWALL	8.00	EACH	575.00	4,600.00			-		-	-		-	-	4,600.00		

Progress Estimate - Unit Price Work

Contractor's Application for Payment

Owner:	City of Forest Lake	Owner's Project No.:	
Engineer:	Bolton & Menk, Inc.	Engineer's Project No.:	0N1.131631
Contractor:	Forest Lake Contracting, Inc.	Agency's Project No.:	SAP 214-594-002
Project:	Eureka Avenue Improvements		
Contract:			

Application No.: 1 Application Period: From 11/17/25 to 12/19/25 Application Date: 12/31/25

A Bid Item No.	B Description	C Item Quantity	D Units	E Unit Price (\$)	F Value of Bid Item (C X E) (\$)	Previous Estimate		Work Completed		I Materials Currently Stored (not in G) (\$)	J Work Completed and Materials Stored to Date (H + I) (\$)	K % of Value of Item (J / F) (%)	L Balance to Finish (F - J) (\$)
						F1 Quantity Previous Estimate	F2 Value Previous Estimate	G Estimated Quantity Incorporated in the Work	H Value of Work Completed to Date (E X G) (\$)				
50	DRAINAGE SYSTEM TYPE SPECIAL	1.00	LUMP SUM	10,000.00	10,000.00		-	-	-		-		10,000.00
51	6" PVC PIPE DRAIN CLEANOUT	3.00	EACH	425.00	1,275.00		-	-	-		-		1,275.00
52	4" TP PIPE DRAIN	173.00	LIN FT	11.00	1,903.00		-	-	-		-		1,903.00
53	6" PERF PVC PIPE DRAIN	155.00	LIN FT	18.00	2,790.00		-	-	-		-		2,790.00
54	4" PERF PE PIPE DRAIN	800.00	LIN FT	4.00	3,200.00		-	-	-		-		3,200.00
55	15" RC PIPE SEWER DES 3006 CL V	154.00	LIN FT	79.00	12,166.00		-	-	-		-		12,166.00
56	30" RC PIPE SEWER DES 3006 CL III	24.00	LIN FT	280.00	6,720.00		-	-	-		-		6,720.00
57	60" SPAN RC ELLIPTICAL PIPE SEWER HE CLASS II	48.00	LIN FT	340.00	16,320.00		-	-	-		-		16,320.00
58	TEMPORARY BYPASS PUMPING	1.00	LUMP SUM	10,000.00	10,000.00		-	-	-		-		10,000.00
59	CONNECT TO EXISTING STORM SEWER	3.00	EACH	800.00	2,400.00		-	-	-		-		2,400.00
60	CONNECT TO EXISTING FORCE MAIN	1.00	EACH	3,500.00	3,500.00		-	-	-		-		3,500.00
61	4" HDPE PIPE SEWER-DIRECTIONAL DRILLED	3,410.00	LIN FT	45.00	153,450.00		-	-	-		-		153,450.00
62	CONSTRUCT DRAINAGE STRUCTURE DESIGN SPECIAL 1	2.00	EACH	5,700.00	11,400.00		-	-	-		-		11,400.00
63	CONSTRUCT DRAINAGE STRUCTURE DESIGN SPECIAL 2	1.00	EACH	12,000.00	12,000.00		-	-	-		-		12,000.00
64	CONNECT INTO EXISTING MANHOLE	1.00	EACH	1,900.00	1,900.00		-	-	-		-		1,900.00
65	DRAINAGE STRUCTURE LINER	4.00	LIN FT	2,000.00	8,000.00		-	-	-		-		8,000.00
66	RANDOM RIPRAP CLASS III	450.00	CU YD	150.00	67,500.00		-	-	-		-		67,500.00
67	6" CONCRETE WALK FOR PEDESTRIAN CURB RAMPS	1,050.00	SQ FT	14.00	14,700.00		-	-	-		-		14,700.00
68	CONCRETE CURB & GUTTER DESIGN B418	5,890.00	LIN FT	19.00	111,910.00		-	-	-		-		111,910.00
69	TRUNCATED DOMES	156.00	SQ FT	56.00	8,736.00		-	-	-		-		8,736.00
70	PORTABLE PRECAST CONC BARRIER DES 8337	2,400.00	LIN FT	15.00	36,000.00		-	-	-		-		36,000.00
71	TEMPORARY FENCE DESIGN SPECIAL	1,720.00	LIN FT	8.50	14,620.00		-	1,724.00	14,654.00		14,654.00	100%	(34.00)
72	INSTALL CHAIN LINK FENCE	1,720.00	LIN FT	27.75	47,730.00		-	-	-		-		47,730.00
73	TRAFFIC CONTROL SUPERVISOR	1.00	LUMP SUM	500.00	500.00		-	-	-		-		500.00
74	TRAFFIC CONTROL	1.00	LUMP SUM	18,000.00	18,000.00		-	0.20	3,600.00		3,600.00	20%	14,400.00
75	TEMPORARY IMPACT ATTENUATOR	4.00	ASSEMBLY	3,000.00	12,000.00		-	-	-		-		12,000.00
76	CONSTRUCTION SIGN-SPECIAL	100.00	SQ FT	25.00	2,500.00		-	-	-		-		2,500.00
77	INSTALL SIGN TYPE C	2.00	EACH	150.00	300.00		-	-	-		-		300.00
78	OBJECT MARKER	21.00	EACH	95.00	1,995.00		-	-	-		-		1,995.00
79	SIGN PANELS TYPE C	122.00	SQ FT	75.00	9,150.00		-	-	-		-		9,150.00
80	SIGN SPECIAL (2 - 9" NAME BLADES) - 6" LETTERING	1.00	EACH	350.00	350.00		-	-	-		-		350.00
81	SIGN SPECIAL (2 - 12" NAME BLADES) - 8" LETTERING	1.00	EACH	400.00	400.00		-	-	-		-		400.00
82	PEDESTRIAN CROSSWALK FLASHER SYSTEM	1.00	SYSTEM	26,150.00	26,150.00		-	-	-		-		26,150.00
83	STABILIZED CONSTRUCTION EXIT	1.00	LUMP SUM	3,500.00	3,500.00		-	-	-		-		3,500.00
84	EROSION CONTROL SUPERVISOR	1.00	LUMP SUM	2,500.00	2,500.00		-	-	-		-		2,500.00
85	STORM DRAIN INLET PROTECTION	8.00	EACH	175.00	1,400.00		-	-	-		-		1,400.00
86	CULVERT END CONTROLS	7.00	EACH	400.00	2,800.00		-	-	-		-		2,800.00
87	SILT FENCE; TYPE MS	11,700.00	LIN FT	2.25	26,325.00		-	1,735.00	3,903.75		3,903.75	15%	22,421.25
88	FLOTATION SILT CURTAIN TYPE STILL WATER	1,350.00	LIN FT	19.50	26,325.00		-	-	-		-		26,325.00
89	SEDIMENT CONTROL LOG TYPE COMPOST	11,750.00	LIN FT	2.50	29,375.00		-	422.00	1,055.00		1,055.00	4%	28,320.00
90	COMMON TOPSOIL BORROW (LV)	2,200.00	CU YD	16.00	35,200.00		-	-	-		-		35,200.00
91	TEMPORARY POLY COVERING	10,200.00	SQ YD	2.00	20,400.00		-	-	-		-		20,400.00
92	WATER (FOR TURF ESTABLISHMENT)	80.00	MGAL	95.00	7,600.00		-	-	-		-		7,600.00
93	VEGETATION ESTABLISHMENT	1.00	LUMP SUM	5,200.00	5,200.00		-	-	-		-		5,200.00
94	TEMPORARY HYDRAULIC MULCH MATRIX	15,000.00	SQ YD	0.54	8,100.00		-	-	-		-		8,100.00
95	SEEDING, INCL SEED MIX 25-141, FERTILIZER, REPP CAT 20	11,630.00	SQ YD	2.15	25,004.50		-	-	-		-		25,004.50
96	SEEDING, INCL SEED MIX 33-261, FERTILIZER	500.00	SQ YD	3.95	1,975.00		-	-	-		-		1,975.00
97	SEEDING, INCL SEED MIX 34-171, MULCH MATERIAL TYPE 3	1,000.00	SQ YD	4.15	4,150.00		-	-	-		-		4,150.00
98	SEEDING, INCL SEED MIX 35-241, FERTILIZER, REPP CAT 20	1,700.00	SQ YD	2.25	3,825.00		-	-	-		-		3,825.00
99	LIVE STAKES	200.00	EACH	22.50	4,500.00		-	-	-		-		4,500.00

Progress Estimate - Unit Price Work

Contractor's Application for Payment

Owner:	City of Forest Lake	Owner's Project No.:	
Engineer:	Bolton & Menk, Inc.	Engineer's Project No.:	0N1.131631
Contractor:	Forest Lake Contracting, Inc.	Agency's Project No.:	SAP 214-594-002
Project:	Eureka Avenue Improvements		
Contract:			

Application No.:		Application Period:		From		to		Application Date:					
1		11/17/25		12/19/25		12/31/25							
A	B	C	D	E	F	F1	F2	G	H	I	J	K	L
Bid Item No.	Description	Contract Information				Previous Estimate		Work Completed		Materials Currently Stored (not in G) (\$)	Work Completed and Materials Stored to Date (H + I) (\$)	% of Value of Item (J / F) (%)	Balance to Finish (F - J) (\$)
		Item Quantity	Units	Unit Price (\$)	Value of Bid Item (C X E) (\$)	Quantity Previous Estimate	Value Previous Estimate	Estimated Quantity Incorporated in the Work	Value of Work Completed to Date (E X G) (\$)				
100	REINFORCED SOIL LIFT (CV)	200.00	CU YD	150.00	30,000.00		-	-	-		-		30,000.00
101	4" SOLID LINE MULTI COMP	6,200.00	LIN FT	0.74	4,588.00		-	-	-		-		4,588.00
102	4" DBLE SOLID LINE MULTI COMP	5,640.00	LIN FT	1.48	8,347.20		-	-	-		-		8,347.20
103	PAVEMENT MESSAGE MULTI COMP	5.00	SQ FT	20.00	100.00		-	-	-		-		100.00
104	CROSSWALK MULTI COMP	192.00	SQ FT	5.70	1,094.40		-	-	-		-		1,094.40
	BASE BID TOTAL				3,325,093.50				50,847.75		55,707.75	2%	3,269,385.75
ALTERNATE 3: ADDITIONAL SHORELINE RESTORATION (RCWD)													
105	SEEDING, INCL SEED MIX 34-261	500.00	SQ YD	6.00	3,000.00		-	-	-		-		3,000.00
106	SANDY CLAY LOAM TOPSOIL BORROW - MODIFIED (LV)	200.00	CU YD	50.00	10,000.00		-	-	-		-		10,000.00
107	LIVE STAKES	200.00	EACH	22.50	4,500.00		-	-	-		-		4,500.00
108	LIVE FASCINE BUNDLE	750.00	LIN FT	35.00	26,250.00		-	-	-		-		26,250.00
	ALTERNATE 3: ADDITIONAL SHORELINE RESTORATION (RCWD) TOTAL				43,750.00								43,750.00
ALTERNATE 4: DECORATIVE BLUE METAL RAILING													
109	ORNAMENTAL METAL RAILING PC	350.00	LIN FT	296.00	103,600.00		-	-	-		-		103,600.00
110	PIPE RAILING DESIGN SPECIAL	(350.00)	LIN FT	242.00	(84,700.00)		-	-	-		-		(84,700.00)
111	ALTERNATE 4: DECORATIVE BLUE METAL RAILING TOTAL				18,900.00								18,900.00
BASE BID + ALTERNATE 3 + ALTERNATE 4 TOTAL					\$ 3,387,743.50		\$ -		\$ 50,847.75	\$ 4,860.00	\$ 55,707.75	2%	\$ 3,332,035.75

**Office of Engineering**

1408 Lake Street South
Forest Lake, MN 55025
www.ci.forest-lake.mn.us

January 12, 2026

Honorable Mayor and City Council
City of Forest Lake
1408 Lake Street South
Forest Lake, MN 55025

RE: Suite Living aka DigniCare Site Improvements
Final Project Acceptance
Project No. N15.106081, Task 89

Dear Mayor and Council:

The Representatives from Suite Living have requested formal acceptance of the site improvements as identified within the Development Agreement. The project included construction of a commercial building, parking lot improvements, installation of sanitary & water services, storm sewer improvements, landscaping improvements and site improvements including pedestrian facilities. Majority of the improvements were completed in 2022 and restoration, wear course paving items completed in 2023 along with final punch list items in 2025.

We have reviewed the project with City Staff and Rice Creek Watershed District and has been determined all the constructed improvements are in general conformance with the plans approved by the City. A copy of the Project Acceptance form is enclosed for Council consideration of final acceptance, upon approval signatures will be obtained.

At this time, we recommend the City Council consider formal Project Acceptance of the project. In addition, completed work is past the warranty period so no financials will be held for future warranty. Site inspections were completed prior to the warranty expiration date and no corrective work was identified.

Acceptance should be contingent upon payment of any outstanding city or consultant fees for site review and preparation of acceptance documents. We request that the City Council consider the request to reduce the financial securities for the site improvements **and to authorize staff to make release payments according to their approval at the meeting.** Please feel free to contact me if there are any questions or require any additional information.

Sincerely,

Ryan J. Goodman, P.E.
City Engineer
612-597-7140



PROJECT ACCEPTANCE FORM

Suite Living aka DigniCare Site Improvements

CITY OF FOREST LAKE

Project No. N15.106081, Phase 89

RECOMMENDATION FOR ACCEPTANCE

The project included construction of a commercial building, parking lot improvements, installation of sanitary & water services, storm sewer improvements, landscaping improvements and site improvements including pedestrian facilities. Majority of the improvements were completed in 2022 and restoration, wear course paving items completed in 2023 along with final punch list items in 2025.

This project was constructed in general conformance with standard policy and procedures of the City of Forest Lake. The work is complete and in general conformance with the plans and specifications. Therefore, this project is recommended for formal acceptance by the City Council.

_____ **Date:** _____
City Engineer

_____ **Date:** _____
Public Works Director

_____ **Date:** _____
Finance Director

_____ **Date:** _____
Community Development Director

_____ **Date:** _____
Fire Chief

City Council Acceptance Date: _____

STAFF REPORT



MEETING DATE: January 12, 2026
TO: Mayor Roberts and City Council Members
STAFF ORIGINATOR: Jolleen Chaika, Assistant City Administrator/Clerk
AGENDA ITEM: Gambling Permit Approval

INTRODUCTION:

Non-profit organizations must obtain City approval to obtain an exempt or excluded gambling permit for bingo or raffle events. The Church of St. Peter has applied to conduct a raffle at the church on April 24, 2026 and Roxie's Hope has applied to conduct bingo at the Legion on April 11, 2026 and November 7, 2026.

BACKGROUND:

Pursuant to Minn. Stat. 349.166, organizations are eligible to obtain an excluded or exempt permit to conduct bingo or a raffle without obtaining a full gambling license and without abiding by all provisions required by licensed organizations if:

Exempt Gambling Permit (LG220):

- The organization conducts lawful gambling on five or less days per year;
- The organization does not award more than \$50,000 in prizes for lawful gambling in a calendar year;
- The organization submits a board-prescribed application and pays a fee of \$100 to the board for each gambling occasion, and receives an exempt permit number from the board...The application must include the date and location of the occasion and the types of lawful gambling to be conducted;
- The organization notifies the local government unit 30 days before the lawful gambling occasion;
- The organization purchases all gambling equipment and supplies from a licensed distributor; and,
- The organization reports to the board, on a single-page form prescribed by the board, within 30 days of each gambling occasion, the gross receipts, prizes, expenses, expenditures of net profits from the occasion, and the identification of the licensed distributor from whom all gambling equipment was purchased.

Additionally, City Ordinance, Section 116.10 requires that any organization applying for any lawful gambling permit under Minn. Stat. 349.166 must obtain a local (city) permit specific to the dates. No background check is required for exempt or excluded gambling permit approval.

The Church of St. Peter and Roxie's Hope meet state and local requirements for local approval of the submitted excluded and exempt applications.

RECOMMENDATION:

Staff recommends Council move to approve the LG220 applications for St. Peter's and Roxie's Hope and authorize the Assistant City Administrator/Clerk to sign applications for remittance to the Minnesota Gambling Control Board.

ATTACHMENTS:

LG220 – Church of St. Peter

LG220 – Roxie's Hope

MINNESOTA LAWFUL GAMBLING
LG220 Application for Exempt Permit

An exempt permit may be issued to a nonprofit organization that:

- conducts lawful gambling on five or fewer days, and
- awards less than \$50,000 in prizes during a calendar year.

If total raffle prize value for the calendar year will be \$1,500 or less, contact the Licensing Specialist assigned to your county by calling 651-539-1900.

Application Fee (non-refundable)

Applications are processed in the order received. If the application is postmarked or received 30 days or more before the event, the application fee is **\$100**; otherwise the fee is **\$150**.

Due to the high volume of exempt applications, payment of additional fees prior to 30 days before your event will not expedite service, nor are telephone requests for expedited service accepted.

ORGANIZATION INFORMATION

Organization Name: Church and School of St. Peter Previous Gambling Permit Number: X-82037

Minnesota Tax ID Number, if any: 8607689 Federal Employer ID Number (FEIN), if any: 41-0799304

Mailing Address: 1250 South Shore Drive

City: Forest Lake State: MN Zip: 55025 County: Washington

Name of Chief Executive Officer (CEO): Fr. Daniel Bodin, Pastor

CEO Daytime Phone: [REDACTED] CEO Email: [REDACTED]
(permit will be emailed to this email address unless otherwise indicated below)

Email permit to (if other than the CEO): [REDACTED]

NONPROFIT STATUS

Type of Nonprofit Organization (check one):

Fraternal Religious Veterans Other Nonprofit Organization

Attach a copy of one of the following showing proof of nonprofit status:

(DO NOT attach a sales tax exempt status or federal employer ID number, as they are not proof of nonprofit status.)

A current calendar year Certificate of Good Standing
 Don't have a copy? Obtain this certificate from:
 MN Secretary of State, Business Services Division Secretary of State website, phone numbers:
 60 Empire Drive, Suite 100 www.sos.state.mn.us
 St. Paul, MN 55103 651-296-2803, or toll free 1-877-551-6767

IRS income tax exemption (501(c)) letter in your organization's name
 Don't have a copy? To obtain a copy of your federal income tax exempt letter, have an organization officer contact the IRS toll free at 1-877-829-5500.

IRS - Affiliate of national, statewide, or international parent nonprofit organization (charter)
 If your organization falls under a parent organization, attach copies of both of the following:
 1. IRS letter showing your parent organization is a nonprofit 501(c) organization with a group ruling; and
 2. the charter or letter from your parent organization recognizing your organization as a subordinate.

GAMBLING PREMISES INFORMATION

Name of premises where the gambling event will be conducted (for raffles, list the site where the drawing will take place): Church and School of St. Peter

Physical Address (do not use P.O. box): 1250 South Shore Drive

Check one:
 City: Forest Lake Zip: 55025 County: Washington
 Township: _____ Zip: _____ County: _____

Date(s) of activity (for raffles, indicate the date of the drawing): 04-24-2026

Check each type of gambling activity that your organization will conduct:
 Bingo Paddlewheels Pull-Tabs Tipboards Raffle

Gambling equipment for bingo paper, bingo boards, raffle boards, paddlewheels, pull-tabs, and tipboards must be obtained from a distributor licensed by the Minnesota Gambling Control Board. EXCEPTION: Bingo hard cards and bingo ball selection devices may be borrowed from another organization authorized to conduct bingo. To find a licensed distributor, go to www.mn.gov/gcb and click on **Distributors** under the **List of Licensees** tab, or call 651-539-1900.

LG220 Application for Exempt Permit

LOCAL UNIT OF GOVERNMENT ACKNOWLEDGMENT (required before submitting application to the Minnesota Gambling Control Board)

<p style="text-align: center;">CITY APPROVAL for a gambling premises located within city limits</p> <p><input type="checkbox"/> The application is acknowledged with no waiting period.</p> <p><input type="checkbox"/> The application is acknowledged with a 30-day waiting period, and allows the Board to issue a permit after 30 days (60 days for a 1st class city).</p> <p><input type="checkbox"/> The application is denied.</p> <p>Print City Name: _____</p> <p>Signature of City Personnel: _____</p> <p>_____</p> <p>Title: _____ Date: _____</p> <div style="border: 1px solid black; padding: 5px; text-align: center; margin-top: 20px;"> <p>The city or county must sign before submitting application to the Gambling Control Board.</p> </div>	<p style="text-align: center;">COUNTY APPROVAL for a gambling premises located in a township</p> <p><input type="checkbox"/> The application is acknowledged with no waiting period.</p> <p><input type="checkbox"/> The application is acknowledged with a 30-day waiting period, and allows the Board to issue a permit after 30 days.</p> <p><input type="checkbox"/> The application is denied.</p> <p>Print County Name: _____</p> <p>Signature of County Personnel: _____</p> <p>_____</p> <p>Title: _____ Date: _____</p> <p>TOWNSHIP (if required by the county) On behalf of the township, I acknowledge that the organization is applying for exempted gambling activity within the township limits. (A township has no statutory authority to approve or deny an application, per Minn. Statutes, section 349.213.)</p> <p>Print Township Name: _____</p> <p>Signature of Township Officer: _____</p> <p>_____</p> <p>Title: _____ Date: _____</p>
---	---

CHIEF EXECUTIVE OFFICER'S SIGNATURE (required)

The information provided in this application is complete and accurate to the best of my knowledge. I acknowledge that the financial report will be completed and returned to the Board within 30 days of the event date.

Chief Executive Officer's Signature: *Fr. Daniel Bodin* Date: 12/10/2025
(Signature must be CEO's signature; designee may not sign)

Print Name: Fr. Daniel Bodin, Pastor

REQUIREMENTS	MAIL APPLICATION AND ATTACHMENTS
---------------------	---

Complete a separate application for:

- all gambling conducted on two or more consecutive days; or
- all gambling conducted on one day.

Only one application is required if one or more raffle drawings are conducted on the same day.

Financial report to be completed within 30 days after the gambling activity is done:
A financial report form will be mailed with your permit. Complete and return the financial report form to the Gambling Control Board.

Your organization must keep all exempt records and reports for 3-1/2 years (Minn. Statutes, section 349.166, subd. 2(f)).

Mail application with:

_____ a copy of your proof of nonprofit status; and

_____ application fee (non-refundable). If the application is postmarked or received 30 days or more before the event, the application fee is **\$100**; otherwise the fee is **\$150**. Make check payable to **State of Minnesota**.

To: Minnesota Gambling Control Board
1711 West County Road B, Suite 300 South
Roseville, MN 55113

Questions?
Call the Licensing Section of the Gambling Control Board at 651-539-1900.

<p>Data privacy notice: The information requested on this form (and any attachments) will be used by the Gambling Control Board (Board) to determine your organization's qualifications to be involved in lawful gambling activities in Minnesota. Your organization has the right to refuse to supply the information; however, if your organization refuses to supply this information, the Board may not be able to determine your organization's qualifications and, as a consequence, may refuse to issue a permit. If your organization supplies the information requested, the Board will be able to process the</p>	<p>application. Your organization's name and address will be public information when received by the Board. All other information provided will be private data about your organization until the Board issues the permit. When the Board issues the permit, all information provided will become public. If the Board does not issue a permit, all information provided remains private, with the exception of your organization's name and address which will remain public. Private data about your organization are available to Board members, Board staff whose work requires access to the information; Minnesota's Depart-</p>	<p>ment of Public Safety; Attorney General; Commissioners of Administration, Minnesota Management & Budget, and Revenue; Legislative Auditor, national and international gambling regulatory agencies; anyone pursuant to court order; other individuals and agencies specifically authorized by state or federal law to have access to the information; individuals and agencies for which law or legal order authorizes a new use or sharing of information after this notice was given; and anyone with your written consent.</p>
---	--	--

This form will be made available in alternative format (i.e. large print, braille) upon request.

MINNESOTA LAWFUL GAMBLING
LG220 Application for Exempt Permit

An exempt permit may be issued to a nonprofit organization that:

- conducts lawful gambling on five or fewer days, and
- awards less than \$50,000 in prizes during a calendar year.

If total raffle prize value for the calendar year will be \$1,500 or less, contact the Licensing Specialist assigned to your county by calling 651-539-1900.

Application Fee (non-refundable)
Applications are processed in the order received. If the application is postmarked or received 30 days or more before the event, the application fee is **\$100**; otherwise the fee is **\$150**.
Due to the high volume of exempt applications, payment of additional fees prior to 30 days before your event will not expedite service, nor are telephone requests for expedited service accepted.

ORGANIZATION INFORMATION

Organization Name: Roxie's Hope Previous Gambling Permit Number: X- 94885-25-010

Minnesota Tax ID Number, if any: 87-1779154 Federal Employer ID Number (FEIN), if any: _____

Mailing Address: P.O. Box 469

City: Cambridge State: MN Zip: 55008 County: Isanti

Name of Chief Executive Officer (CEO): Rahya Geisker

CEO Daytime Phone: [REDACTED] CEO Email: [REDACTED]
(permit will be emailed to this email address unless otherwise indicated below)

Email permit to (if other than the CEO): Same

NONPROFIT STATUS

Type of Nonprofit Organization (check one):

Fraternal Religious Veterans Other Nonprofit Organization

Attach a copy of one of the following showing proof of nonprofit status:

(DO NOT attach a sales tax exempt status or federal employer ID number, as they are not proof of nonprofit status.)

A current calendar year Certificate of Good Standing
Don't have a copy? Obtain this certificate from:
MN Secretary of State, Business Services Division
60 Empire Drive, Suite 100
St. Paul, MN 55103
Secretary of State website, phone numbers:
www.sos.state.mn.us
651-296-2803, or toll free 1-877-551-6767

IRS income tax exemption (501(c)) letter in your organization's name
Don't have a copy? To obtain a copy of your federal income tax exempt letter, have an organization officer contact the IRS toll free at 1-877-829-5500.

IRS - Affiliate of national, statewide, or international parent nonprofit organization (charter)
If your organization falls under a parent organization, attach copies of both of the following:
1. IRS letter showing your parent organization is a nonprofit 501(c) organization with a group ruling; and
2. the charter or letter from your parent organization recognizing your organization as a subordinate.

GAMBLING PREMISES INFORMATION

Name of premises where the gambling event will be conducted (for raffles, list the site where the drawing will take place): American Legion Post 225

Physical Address (do not use P.O. box): 355 W Broadway Ave. Forest Lake, MN 55025

Check one:
 City: Forest Lake Zip: 55025 County: Washington

Township: _____ Zip: _____ County: _____

Date(s) of activity (for raffles, indicate the date of the drawing): April 11, 2026 + November 7, 2026

Check each type of gambling activity that your organization will conduct:

Bingo Paddlewheels Pull-Tabs Tipboards Raffle

Gambling equipment for bingo paper, bingo boards, raffle boards, paddlewheels, pull-tabs, and tipboards must be obtained from a distributor licensed by the Minnesota Gambling Control Board. EXCEPTION: Bingo hard cards and bingo ball selection devices may be borrowed from another organization authorized to conduct bingo. To find a licensed distributor, go to www.mn.gov/gcb and click on **Distributors** under the **List of Licensees** tab, or call 651-539-1900.

LOCAL UNIT OF GOVERNMENT ACKNOWLEDGMENT (required before submitting application to the Minnesota Gambling Control Board)

<p style="text-align: center;">CITY APPROVAL for a gambling premises located within city limits</p> <p><input type="checkbox"/> The application is acknowledged with no waiting period.</p> <p><input type="checkbox"/> The application is acknowledged with a 30-day waiting period, and allows the Board to issue a permit after 30 days (60 days for a 1st class city).</p> <p><input type="checkbox"/> The application is denied.</p> <p>Print City Name: _____</p> <p>Signature of City Personnel: _____</p> <p>Title: _____ Date: _____</p> <div style="border: 1px solid black; padding: 5px; text-align: center; margin-top: 20px;"> <p>The city or county must sign before submitting application to the Gambling Control Board.</p> </div>	<p style="text-align: center;">COUNTY APPROVAL for a gambling premises located in a township</p> <p><input type="checkbox"/> The application is acknowledged with no waiting period.</p> <p><input type="checkbox"/> The application is acknowledged with a 30-day waiting period, and allows the Board to issue a permit after 30 days.</p> <p><input type="checkbox"/> The application is denied.</p> <p>Print County Name: _____</p> <p>Signature of County Personnel: _____</p> <p>Title: _____ Date: _____</p> <p>TOWNSHIP (if required by the county) On behalf of the township, I acknowledge that the organization is applying for exempted gambling activity within the township limits. (A township has no statutory authority to approve or deny an application, per Minn. Statutes, section 349.213.)</p> <p>Print Township Name: _____</p> <p>Signature of Township Officer: _____</p> <p>Title: _____ Date: _____</p>
--	---

CHIEF EXECUTIVE OFFICER'S SIGNATURE (required)

The information provided in this application is complete and accurate to the best of my knowledge. I acknowledge that the financial report will be completed and returned to the Board within 30 days of the event date.

Chief Executive Officer's Signature: _____ Date: _____
(Signature must be CEO's signature; designee may not sign)

Print Name: _____

REQUIREMENTS	MAIL APPLICATION AND ATTACHMENTS
---------------------	---

<p>Complete a separate application for:</p> <ul style="list-style-type: none"> • all gambling conducted on two or more consecutive days; or • all gambling conducted on one day. <p>Only one application is required if one or more raffle drawings are conducted on the same day.</p> <p>Financial report to be completed within 30 days after the gambling activity is done: A financial report form will be mailed with your permit. Complete and return the financial report form to the Gambling Control Board.</p> <p>Your organization must keep all exempt records and reports for 3-1/2 years (Minn. Statutes, section 349.166, subd. 2(f)).</p>	<p>Mail application with:</p> <p>_____ a copy of your proof of nonprofit status; and</p> <p>_____ application fee (non-refundable). If the application is postmarked or received 30 days or more before the event, the application fee is \$100; otherwise the fee is \$150. Make check payable to State of Minnesota.</p> <p>To: Minnesota Gambling Control Board 1711 West County Road B, Suite 300 South Roseville, MN 55113</p> <p>Questions? Call the Licensing Section of the Gambling Control Board at 651-539-1900.</p>
---	---

<p>Data privacy notice: The information requested on this form (and any attachments) will be used by the Gambling Control Board (Board) to determine your organization's qualifications to be involved in lawful gambling activities in Minnesota. Your organization has the right to refuse to supply the information; however, if your organization refuses to supply this information, the Board may not be able to determine your organization's qualifications and, as a consequence, may refuse to issue a permit. If your organization supplies the information requested, the Board will be able to process the</p>	<p>application. Your organization's name and address will be public information when received by the Board. All other information provided will be private data about your organization until the Board issues the permit. When the Board issues the permit, all information provided will become public. If the Board does not issue a permit, all information provided remains private, with the exception of your organization's name and address which will remain public. Private data about your organization are available to Board members, Board staff whose work requires access to the information; Minnesota's Department of Public Safety; Attorney General; Commissioners of Administration, Minnesota Management & Budget, and Revenue; Legislative Auditor, national and international gambling regulatory agencies; anyone pursuant to court order; other individuals and agencies specifically authorized by state or federal law to have access to the information; individuals and agencies for which law or legal order authorizes a new use or sharing of information after this notice was given; and anyone with your written consent.</p>	<p>ment of Public Safety; Attorney General; Commissioners of Administration, Minnesota Management & Budget, and Revenue; Legislative Auditor, national and international gambling regulatory agencies; anyone pursuant to court order; other individuals and agencies specifically authorized by state or federal law to have access to the information; individuals and agencies for which law or legal order authorizes a new use or sharing of information after this notice was given; and anyone with your written consent.</p>
---	--	--

This form will be made available in alternative format (i.e. large print, braille) upon request.

STAFF REPORT



MEETING DATE: January 12, 2026

TO: Honorable Mayor Roberts and Members of the City Council

STAFF ORIGINATOR: Jolleen Chaika, Assistant City Administrator/Clerk

AGENDA ITEM: Temporary On-Sale Liquor License Application

INTRODUCTION:

St. Peter's Church and Catholic School has submitted an Alcohol and Gambling Enforcement application to obtain a temporary On-Sale Liquor License to allow service of beer at the their 2026 Golden Gala Dinner and Auction event scheduled for April 24, 2026 at the school.

BACKGROUND:

City Code, Chapter 119.03 (4) and Minn. Stat. 340A.404, Subd. 10 allow for the City to issue a temporary on-sale liquor license to club, charitable, religious, or other nonprofit organizations in existence for at least three years, in connection with a social event within the city sponsored by the licensee. At the present time, the City does not have an application for temporary licenses; only the state application has been required to apply for this license.

St. Peter's Church/School will be hosting an event at the school on April 24, 2026 wishes to serve alcoholic beverages at the event. All necessary documentation to verify the Church/school's non-profit status is on file, and the event has been confirmed to be scheduled within the City. All requirements of the City Ordinance have been met. The City Fee Schedule does not require any fee to be paid for this license.

RECOMMENDATION:

Approve the application for a Temporary On-Sale Liquor License to St. Peter's and authorize the City Clerk to sign the application to remit to the State of Minnesota.

ATTACHMENTS:

AGE Temporary On-Sale Application



Minnesota Department of Public Safety
Alcohol and Gambling Enforcement Division
 445 Minnesota Street, Suite 1600, St. Paul, MN 55101
 651-201-7507 TTY 651-282-6555
APPLICATION AND PERMIT FOR A 1 DAY
TO 4 DAY TEMPORARY ON-SALE LIQUOR LICENSE

Name of organization	Date of organization	Tax exempt number
Church and School of St. Peter	11-13-1905	8353887

Organization Address (No PO Boxes)	City	State	Zip Code
1250 South Shore Drive	Forest Lake	MN	55025

Name of person making application	Business phone	Home phone
Christine Erickson	651-982-2217	

Date(s) of event	Type of organization		
April 24, 2026	<input type="checkbox"/> Microdistillery <input type="checkbox"/> Small Brewer <input type="checkbox"/> Club <input type="checkbox"/> Charitable <input checked="" type="checkbox"/> Religious <input type="checkbox"/> Other non-profit		

Organization officer's name	City	State	Zip Code
Fr. Daniel Bodin, Pastor	Forest Lake	MN	55025

Organization officer's name	City	State	Zip Code
		MN	

Organization officer's name	City	State	Zip Code
		MN	

Location where permit will be used. If an outdoor area, describe.
 Multipurpose Room located inside the Church and School of St. Peter building located at 1250 South Shore Drive, Forest Lake, MN 55025.

If the applicant will contract for intoxicating liquor service give the name and address of the liquor license providing the service.
 The Old Log Cabin restaurant, 9726 Scandia Trail N, Forst Lake, MN 55025

If the applicant will carry liquor liability insurance please provide the carrier's name and amount of coverage.
 Catholic Mutual certificate \$500,000 coverage.

APPROVAL

APPLICATION MUST BE APPROVED BY CITY OR COUNTY BEFORE SUBMITTING TO ALCOHOL AND GAMBLING ENFORCEMENT

 City or County approving the license

 Date Approved

 Fee Amount

 Permit Date

Event in conjunction with a community festival Yes No

 City or County E-mail Address

 Current population of city

 Please Print Name of City Clerk or County Official

 Signature City Clerk or County Official

CLERKS NOTICE: Submit this form to Alcohol and Gambling Enforcement Division 30 days prior to event

No Temp Applications faxed or mailed. Only emailed.

ONE SUBMISSION PER EMAIL, APPLICATION ONLY.

PLEASE PROVIDE A VALID E-MAIL ADDRESS FOR THE CITY/COUNTY AS ALL TEMPORARY PERMIT APPROVALS WILL BE SENT BACK VIA EMAIL. E-MAIL THE APPLICATION SIGNED BY CITY/COUNTY TO AGE.TEMPORARYAPPLICATION@STATE.MN.US

STAFF REPORT



MEETING DATE: January 12, 2026

TO: City of Forest Lake City Council

STAFF ORIGINATOR: Steven Gilmore, AICP, Assistant Community Development Director
Madison Richard, Consultant City Planner

AGENDA ITEM: Zoning Ordinance Text Amendment – Towers

INTRODUCTION:

Buell Consulting, Inc. requested a zoning ordinance text amendment to allow wireless communication towers in the Single-Family (SF) Zoning District and to modify several related standards.

The request is informed by a potential future wireless communication tower that has been discussed for property owned by Hosanna Lutheran Church, located at 9300 Scandia Trail N. This location is referenced for informational and contextual purposes only. Any future tower proposal would still require separate permits and approvals.

The Planning Commission held a public hearing and forwarded a recommendation to the City Council. The City Council is now considering final action on the proposed ordinance and resolution.

ANALYSIS:

This analysis is provided to assist the City Council in making a final decision.

Proposal Summary

The applicant requested the following zoning code changes:

- Allow wireless communication towers in the SF District as a Conditional Use
- Reduce the minimum lot size for towers from 10 acres to 2.5 acres
- Reduce required setbacks through use of an engineered fall zone
- Remove the one-mile separation requirement between towers
- Increase the maximum tower height to 125 feet

Staff reviewed each request separately. Staff support allowing towers as a Conditional Use in the SF District, but do not support changes to lot size, setbacks, height, or separation standards.

Conditional Use Permits

A Conditional Use Permit (CUP) allows the City to review certain uses on a case-by-case basis and approve them with conditions to limit potential impacts. The use must meet zoning code standards and any added conditions needed to protect public health, safety, and welfare.

Staff support adding the SF District to the list of zoning districts where towers may be considered with a CUP.

Performance Standards

Lot Size

The applicant requested reducing the minimum lot size to 2.5 acres. Staff do not recommend this change.

The current 10-acre minimum lot size is a generally applicable standard that helps maintain separation from nearby residential uses and limit potential impacts. Properties that meet this standard through lawful means, such as parcel consolidation, may still be considered for a tower, subject to all required permits and approvals.

Setbacks

The applicant requested reduced setbacks and the use of an engineered fall zone, which is an area designed and certified by an engineer to ensure that, if a tower were to fail or collapse, it would fall within a specific area of the site.

Current code requires towers to be set back a distance equal to the full height of the tower from property lines and twice the height of the tower from nearby homes. Staff do not recommend changing these standards because they provide clear and consistent protection for neighboring properties.

Tower Separation

The applicant requested removal of the one-mile separation requirement between wireless communication towers.

Staff recommend retaining the current separation requirement. The separation requirement is a citywide standard intended to prevent over-concentration of towers and reduce visual and neighborhood impacts across the community. The standard continues to serve a valid public purpose and remains appropriate regardless of any individual proposal.

Height

The applicant requested increasing the maximum height to 125 feet.

Staff do not recommend this change. The existing 100-foot height limit helps reduce visual impacts. Any future changes to height standards should be studied more broadly and are not recommended as part of this request.

RECOMMENDATION:

Staff recommend that the City Council approve Ordinance No. 765, allowing wireless communication towers as a conditional use in the Single-Family (SF) Zoning District, and adopt Resolution No. 01-12-26-07 denying the requested changes to lot size, setbacks (including use of a fall zone), tower height, and separation standards. Staff find that these changes would weaken protections for residential neighborhoods and could set an unintended precedent.

Findings of Fact

- Ordinance No. 765 is consistent with the Comprehensive Plan.
- Ordinance No. 765 aligns with the City’s existing residential tower regulations by allowing towers as a Conditional Use in the SF District while keeping current lot size, setback, height, and separation standards.
- Ordinance No. 765 provides a public benefit by supporting improved wireless service while maintaining neighborhood protections.
- The applicant-initiated amendments to reduce minimum lot size, modify setbacks (including a “fall zone”), increase height, and remove separation standards were not approved because they would reduce established residential protections and could create unintended precedent.

Recommended Decision and Conditions

Planning Commission Action and Recommendation

The Planning Commission held a duly noticed public hearing on December 10, 2025. No public comments were received.

During its review, the Planning Commission recommended clarifying that the setback requirement from a “residential dwelling” includes both the principal dwelling and any accessory structures associated with residential use. The clarification is intended to improve clarity and avoid differing interpretations, while maintaining the City’s existing tower setback standards.

The Planning Commission voted 5-0, with one (1) abstention to recommend approval of allowing towers as a Conditional Use in the SF District and recommended denial of the requested changes to performance standards.

City Council Discussion and Determination

Based on the Planning Commission recommendation and Staff analysis, Staff recommend that the City Council take the following actions:

1. Approve Ordinance No. 765 allowing towers as a conditional use in the Single-Family (SF) Zoning District; and
2. Adopt Resolution No. 01-12-26-07 denying the requested changes to lot size, setbacks, tower height, and separation standards.

ATTACHMENTS:

Applicant’s Project Narrative

Single-Family Residential Zoning Map – All Single-Family (SF) Parcels by Lot Size

Single-Family Residential Zoning Map – Institutional/Public Use Parcels within SF by Lot Size

Ordinance No. 765 – Amending Wireless Communication Tower Regulations

Resolution No. 01-12-26-07 – Denial of Applicant-Initiated Tower Ordinance Amendment



SENT VIA EMAIL

October 10, 2025

Madison Richard
City of Forest Lake
1408 Lake Street South
Forest Lake, MN 55025

RE: AT&T Mobility / Text Amendment / Hosanna Lutheran Church / Site Name: Old Log Cabin

Dear Ms. Richard,

Buell Consulting, Inc., on behalf of AT&T Mobility, respectfully submits this request for approval of a text amendment to §153.096(JJ) of the City of Forest Lake's zoning ordinance regarding wireless communication facilities.

The purpose of this proposed amendment is to update zoning provisions to accommodate the construction of a new AT&T cell tower, to be camouflaged as a church steeple, at Hosanna Lutheran Church, as well as on other institutional properties which may be necessary to provide adequate wireless communication services in the future.

Site Address: 9300 Scandia Trail North, Forest Lake, MN 55025

PID: 24.032.21.22.0005 / 23.032.21.11.0014

A text amendment is required as cell towers are not currently recognized as permitted, conditional, or interim uses within the Single-Family Residential District (SF) where the subject property is located. This also precludes the possibility of a variance under current zoning regulations.

The proposed cell tower is intended to improve AT&T wireless service coverage for residents and visitors in the lake area, as well as the surrounding residential and commercial districts. In addition to standard voice, text, and home internet services, this infrastructure will also support AT&T's FirstNet program for first responders. Reliable wireless connectivity is essential for safety on the lake, as mobile phones are often the

sole means of contacting emergency services for many boaters. Following an assessment of several potential sites, AT&T has identified the Hosanna Lutheran Church parcel as the only suitable location for this project.

The requested text amendment would permit cell towers as a conditional use within SF districts containing institutional uses, such as churches or city-owned properties whose primary function is non-residential despite their location in an SF district. Additionally, new requirements would ensure that cell towers are designed to blend with their surroundings through stealth or camouflage measures.

Furthermore, revisions to the following performance standards in §153.096(JJ) are proposed as part of the amendment:

2) *Performance standards for all towers.*

- (b) On any parcel of land zoned for agricultural or residential purposes, the minimum lot size for construction of a tower shall be 10 acres. On a vacant parcel of land zoned for commercial/industrial purposes, the minimum lot size is 2.5 acres. On a parcel of land on which a principal use exists, a tower shall be considered an accessory use and a smaller parcel of land may be leased, provided all standards contained in this chapter can be met.

We propose institutional uses within residentially zoned districts be subject to the 2.5 acre minimum. Many institutional parcels are less than 10 acres in size and thus the larger minimum would be unnecessarily restrictive. Limiting allowable locations for cell towers to institutional uses addresses concerns regarding placement of freestanding towers in single or multi-family residential lots.

- (n) The tower shall be located twice the tower height to any residential dwelling other than the dwelling on the parcel on which the tower is to be located or a minimum of the tower height from any property line. However, towers must meet the setback in the zoning district they are located in if the setback is greater than the height of the tower.

We recommend reducing the minimum setback from residential dwellings to the tower's height. Institutional sites such as Hosanna Church typically feature large buildings and



parking areas. This often means the only available space is near parcel boundaries where meeting the double-height setback requirement is not possible.

Additionally, we request that the property line setback for towers be defined as the “fall zone,” substantiated by an engineering letter confirming the tower will collapse within the property lines. This requirement appears in subsection 2(c) but warrants clarification to specify both the setback and burden of proof.

6) *Additional standards for communication apparatus.*

- (b) No tower shall be over 200 feet in height or within 1 mile of another tower, regardless of municipal boundaries.

Current wireless technology necessitates closer proximity to users, making large separation distances obsolete for determining necessity. A more effective approach requires alternative site analysis per subsection 4(2)(c). Height restrictions may also result in the need for multiple towers within a 1-mile radius. These changes would apply solely to future uses within the City, as the Hosanna site is outside the present separation range.

Thank you in advance for considering our application. Should you have questions or require further details, please contact me via email or telephone at your convenience.

Sincerely,

A handwritten signature in black ink that reads "Blair Ransom".

Blair Ransom

Site Development Agent o/b/o AT&T Mobility

Proposed Location Hosanna Lutheran Church



**Christ Lutheran Church
Eagan, MN**



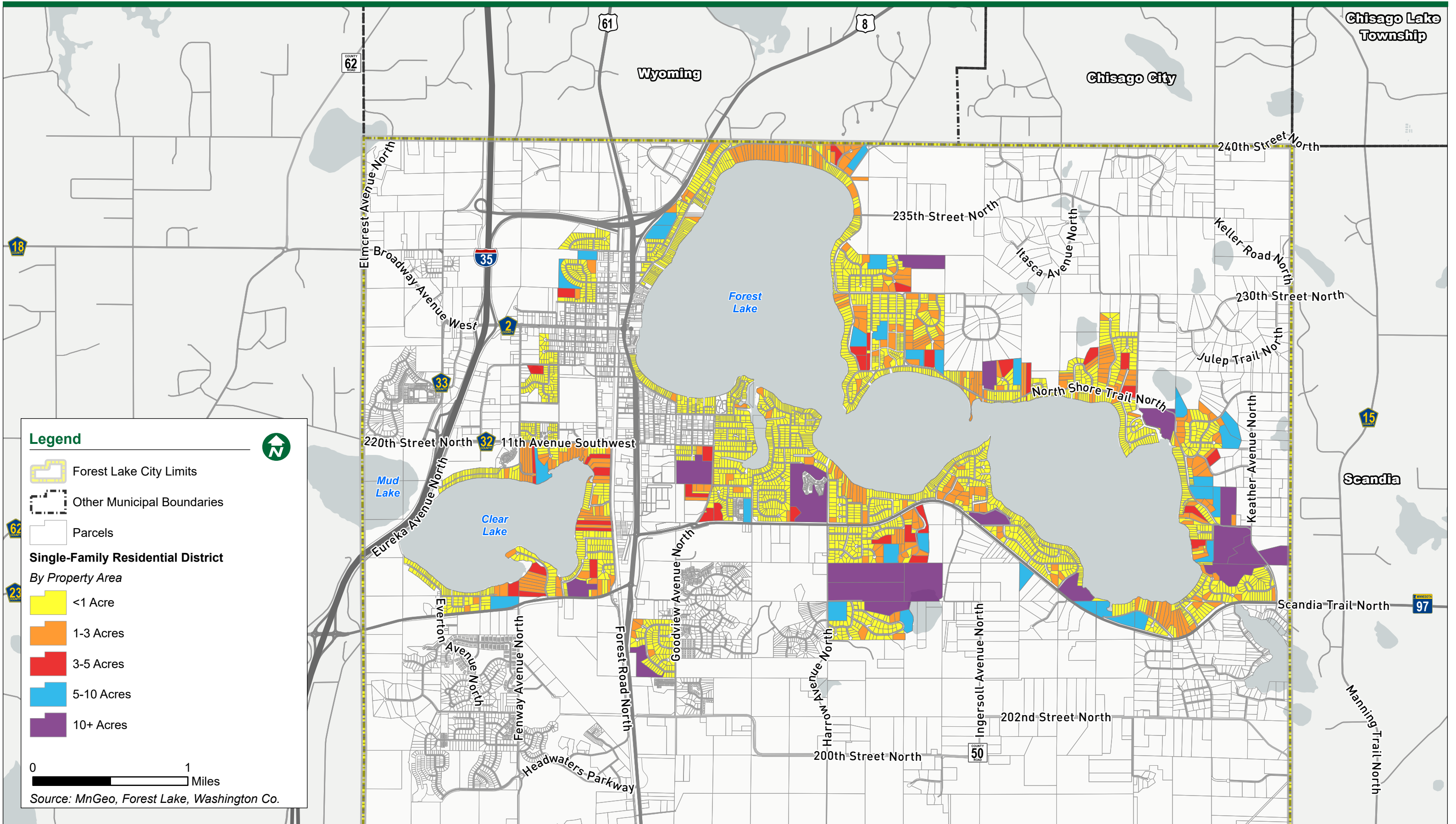

Legend

- Forest Lake City Limits
- Other Municipal Boundaries
- Parcels

Single-Family Residential District

By Property Area

- <1 Acre
- 1-3 Acres
- 3-5 Acres
- 5-10 Acres
- 10+ Acres

0 1
Miles

Source: MnGeo, Forest Lake, Washington Co.



Map Document: \arcserve\lsm_gis\minnesota\FRLK\112526000\Prof\Forest_Lake_Temporary_Planning_Services.aprx | User: davis | Date Saved: 11/17/2025 2:05 AM

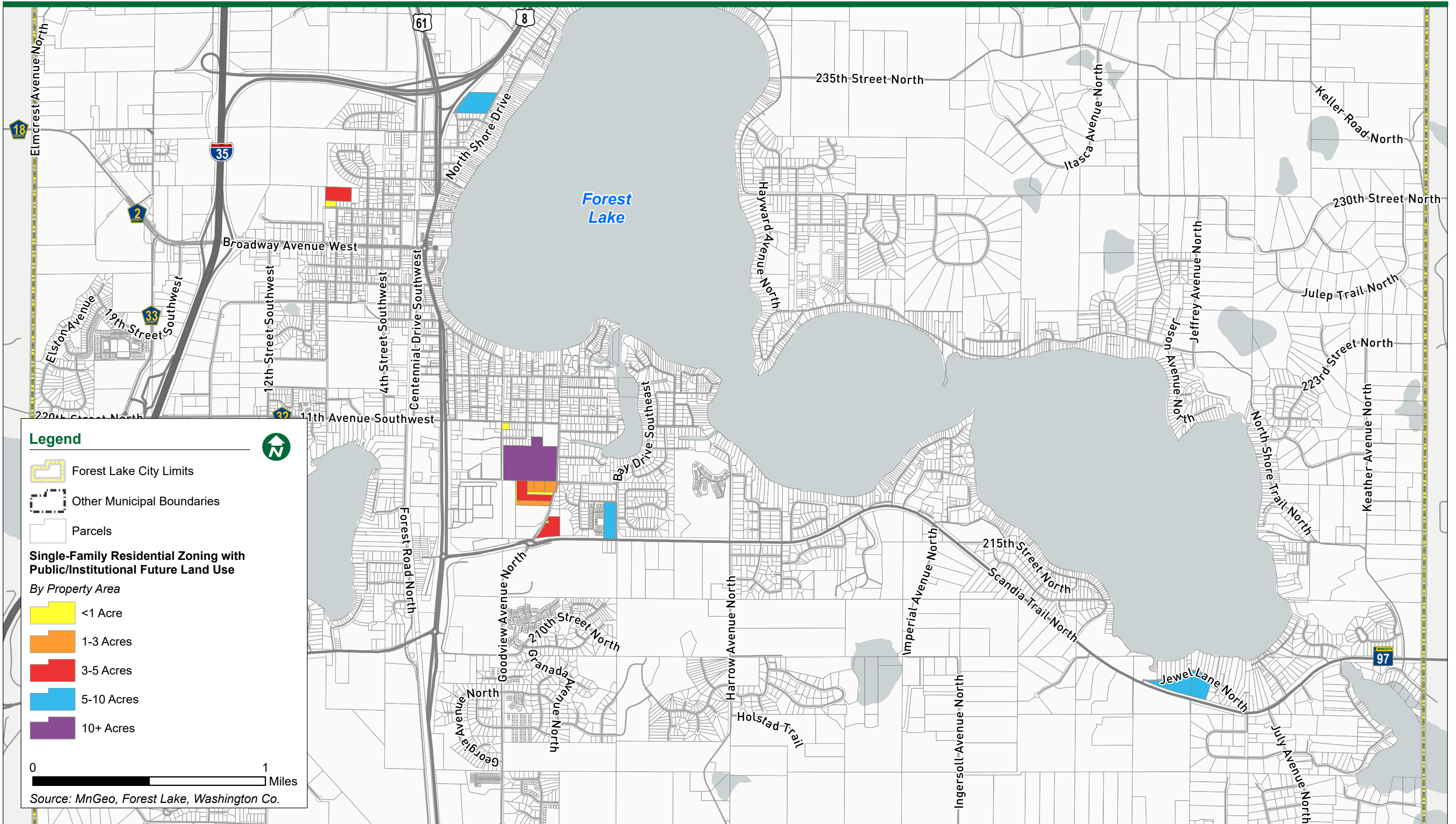

Map Document: \\lscserver1\lscm_gis\minnesota\FRLK\1125262000\Prof\Forest_Lake_Temporary_Planning_Services.aprx | User: davis | Date Saved: 11/17/2025 10:18 AM

**CITY OF FOREST LAKE
WASHINGTON COUNTY, MINNESOTA**

ORDINANCE NO. 765

**AN ORDINANCE AMENDING TITLE XV, CHAPTER 153, SECTION 153.065, SECTION 153.069
AND 153.092, PERTAINING TO WIRELESS COMMUNICATION TOWERS**

THE CITY COUNCIL OF THE CITY OF FOREST LAKE ORDAINS AS FOLLOWS:

Section 1. Amendment. Title XV, Chapter 153, Section 153.065 COMPREHENSIVE USE TABLE of the Forest Lake City Code is hereby amended by allowing Towers – Accessory, and Towers – Permitted, through a Conditional Use Permit.

Section 2. Amendment. Title XV, Chapter 153, Section 153.069 SINGLE-FAMILY (SF) RESIDENTIAL DISTRICTS of the Forest Lake City Code is hereby amended by adding **bold and underline** are proposed additions to the code and deleting the ~~strikeout~~ language as follows:

(E) Conditional uses. Subject to applicable provisions of this chapter, the following are conditional uses in the SF District (requires a conditional use permit based upon procedures set forth in and regulated by § 153.034).

2. Accessory uses.

(d) Tower (see § 153.092).

Section 3. Amendment. Title XV, Chapter 153, Section 153.092 STANDARDS FOR USES of the Forest Lake City Code is hereby amended by adding **bold and underline** are proposed additions to the code and deleting the ~~strikeout~~ language as follows:

(JJ) Towers

(2) Performance standards for all towers.

(n) The tower shall be located **a minimum of** twice the tower height to any residential dwelling other than the dwelling on the parcel on which the tower is to be located or **setback** a minimum **distance** of the tower height from any property line. However, towers must meet the setback in the zoning district they are located in if the setback is greater than the height of the tower. **For purposes of this subsection, “residential dwelling” includes the principal residential structure and any accessory structure associated with a residential dwelling.**

(5) Tower standards by districts. Towers are regulated differently

depending on the zoning district in which the property is located.
The following are the standards in each district:

- (a) Agriculture, Conservancy, and Agricultural Preserve Overlay, ~~and MXR-1~~ districts.
- (b) Rural residential, Single-family residential, and MXR-1 districts.

Section 4. Effective Date. This Ordinance shall be in full force and effect upon its adoption and publication as provided by law.

Passed in regular session of the City Council on the _____ day of _____, 2026.

CITY OF FOREST LAKE

By: _____

Blake Roberts

Its: Mayor

Attested:

By: _____

Jolleen Chaika

Its: Assistant City Administrator

(Published in the *Forest Lake Times* on _____, 2026)

**CITY OF FOREST LAKE
WASHINGTON COUNTY, MINNESOTA**

RESOLUTION NO. 01-12-26-07

**A RESOLUTION ADOPTING WRITTEN STATEMENT OF REASONS FOR DENIAL OF AN
APPLICANT-INITIATED ZONING ORDINANCE TEXT AMENDMENT PERTAINING TO WIRELESS
COMMUNICATION TOWERS**

WHEREAS, the City of Forest Lake received a zoning ordinance text amendment request from Buell Consulting, Inc. (“Applicant”) which would amend Title XV, Chapter 153, Sections 153.065 (Comprehensive Use Table), 153.069 (Single-Family Residential District), and 153.092 (Standards for Uses) by permitting towers in the Single-Family Residential District and establishing certain standards for towers (“tower”); and

WHEREAS, in a duly noticed public hearing held on December 10, 2025, the Planning Commission reviewed the Applicant-initiated zoning ordinance text amendment and recommended approval of allowing towers as a Conditional Use in the Single-Family Residential District while recommending denial of the Applicant’s proposed changes to performance standards; and

WHEREAS, in a duly noticed public hearing held on January 12, 2026, the City Council of Forest Lake moved to approve a modified zoning ordinance text amendment and to deny the Applicant’s Zoning Ordinance Text Amendment as submitted; and

WHEREAS, while zoning ordinance text amendments are legislative actions, the City Council adopts this written statement of reasons to clearly document the basis for its decision and to provide transparency and clarity in the legislative record, consistent with applicable Minnesota law.

NOW THEREFORE IT BE RESOLVED that the City Council of the City of Forest Lake hereby adopts the following written statements:

1. While the Applicant’s request was not prohibited by the Zoning Code, the proposed updates to the wireless communication tower regulations; including reductions to the minimum lot size requirement, modifications to setback standards, increases to maximum tower height, and elimination of minimum tower separation requirements, were determined not to be in the public’s best interest. Approval of these proposed standards would reduce established residential protections and could create unintended precedent for tower placement within residential zoning districts citywide.
2. Forest Lake Ordinance No. 765 reflects the City Council’s decision to approve a modified version of the Applicant-initiated zoning ordinance text amendment by allowing wireless

communication towers as a Conditional Use in the Single-Family Residential Zoning District while retaining existing lot size, setback, height, and separation standards.

- 3. Forest Lake Ordinance No. 765 is consistent with the Comprehensive Plan, aligns with the Zoning Code, and serves the public interest by supporting improved wireless service while maintaining established residential protections.

Adopted by the City Council of the City of Forest Lake on the _____ day of _____, 2026.

CITY OF FOREST LAKE

By: _____
Blake Roberts
Its: Mayor

Attest: _____
Jolleen Chaika
Its: Assistant City Administrator

STAFF REPORT



MEETING DATE: January 12, 2026

TO: Mayor Blake Roberts and City Councilors

STAFF ORIGINATOR: Abbi Wittman, Community Development Director
Madison Richard, Interim City Planner
Nathan Fuerst, Consultant Planner

AGENDA ITEM: Spikes & Houles Phase II – Site Plan Review, Planned Unit Development Review (Preliminary and Final)

INTRODUCTION

The applicant, GLG Forest Lake Properties, LLC., has requested a Preliminary & Final Planned Unit Development, along with an associated Site Plan Review to expand the existing feed store and bring the entirety of the site into compliance with City standards. The Spikes and Houle Feed Mill is located on an approximately 3.59-acre site, currently developed with multiple buildings and gravel drives and parking areas. The proposal is for the construction of a commercial greenhouse structure, nursery yard, and various parking lot and drive areas.

The City is asked to make a determination on the following requests:

- Preliminary & Final Planned Unit Development
- Site Plan Review

The Planning Commission held public hearing and provided a recommendation to the City Council, who makes determination on the requests. Information submitted by the Applicant, including the project narrative, proposed plans, and elevations are appended to this report.

Background

The Spikes and Houles Feed Mill property and building have a long history in Forest Lake. The original grain elevator was constructed in 1916 by EJ Houle, and later incorporated with the Johnson Mill or Red Mill. A gathering point for many of the region's farmers, the Houle Elevator and Feed Mill has served the area's needs as a feed milling and retail operation for over a century. This iconic property, now a fixture in Forest Lake's skyline, was acquired by Gertens in the summer of 2020.

Due to the complexity of the development, and the timing for work on different portions of the site, the project has been split into two separate phases. The Applicant completed Phase I in 2022, which involved the restoration of the existing Houles Feed Mill building.

Since that approval, the Applicant's team have formulated plans on the development of the rest of the site. City staff have met with the Applicant's team multiple times over the years to assist in identifying requirements and to guide the development team through the entitlement process.

ANALYSIS:

Zoning Review and Land Use

The property is zoned within the Downtown Mixed-Use District (MU-1), which permits the existing *retail sales and services* use on the site "by right". The proposed improvements to the site including the commercial greenhouse and nurse yard areas are already part of the existing operations on site. Additionally, as proposed, these uses are incidental to the primary retail use on the property and substantially conform with the retail operation. Accessory uses, taking place within the numerous structures on the property, are considered to be "other uses customarily associated with but subordinate to a permitted use as determined by the city". Staff find that the proposed and existing uses are complimentary to the vision for the site as established by the 2040 Comprehensive Plan and the goals and policies therein.

Planned Unit Development

The purpose of a PUD, as established in City Code Section 153.087 is to *"permit a more creative and flexible regulatory process in guiding land development as compared to the standard development regulations of this chapter. The PUD process provides a joint planning/design effort by the city and the applicants, as opposed to the city establishing limits within which applicants must perform. The intent is to provide a greater degree of creativity and flexibility and promote the health, safety, order, convenience, prosperity, and general welfare of the city and its inhabitants"*. This project is consistent with the City's PUD Development Standards.

The PUD Overlay District, if approved, provides a method for the City to allow a greater degree of creativity and flexibility when reviewing development proposals when compared to the City's standard development regulations. In this instance, the proposed PUD for the commercial greenhouse is to allow for greater flexibility, including building design standards, a reduction in the required landscaping, and a reduction in the number of parking spaces. Information specific to the flexibilities are outlined in this report.

Site Plan Review

City staff reviewed the proposed site improvements against the requirements in the Downtown Mixed Use (MU-1) District, City Code Section 153.084, and the requirements for a detached accessory structure, City Code Section 153.133. A review of these standards is below:

Setbacks, Lot Size, Structure Placement

There is no minimum lot size or width established for properties in the City's MU-1 District. In addition, there are no setbacks for structures unless abutting a residential district.

The applicant is proposing a 6,844 square-foot commercial greenhouse, a 8,910 square-foot nursery yard, the relocation of a 300 square-foot building, and associated paved drive aisles, parking, storage areas, and a stormwater pond.

Parking

Staff do not believe the parking area has ever been reviewed for compliance with the required number of stalls by ordinance for the existing site. At present, the site has parking spread over multiple commonly owned parcels on a substandard surface.

Parking standards are established in City Code Section 153.124, and are based on the proposed use for the site. The applicant is proposing 51 spaces, of which four (4) will be ADA stalls. Flexibility to parking requirements is requested through the PUD. A breakdown of parking standards is provided based on the different proposed uses on the site (both including and not including the proposed nursery yard):

Use	Stalls Required (code requirement per use)	Stalls Proposed
Retail (11,711 sq. ft.)	59 stalls (5 stalls/1,000 gross sq ft)	51 stalls (1 stall/685 gross sq. ft.)
Storage / Greenhouse (14,289 sq. ft.)	7 stalls (.5 stall/1,000 gross sq. ft.)	
Nursey Yard* (8,910 sq. ft.)	22 stalls (2.5 stalls/1,000 gross sq. ft.)	
Total (34,910 sq. ft.)	88 stalls (1 stall/397 gross sq. ft.)	

*this is a seasonal component of the use, and is therefore given a credit of 50% of the amount of parking that *retail* uses would normally require.

Given the nature of this unique retail use, parking demand is not expected to exceed the number of stalls provided on site at most times of the year. This plan will largely bring the parking area into conformance with City performance standards. However, at the Planning Commission hearing, the Commission expressed concern for onsite parking, noting parking congestion concerns when there have been events onsite. Acknowledging event traffic has created parking problems, the landowner has provided a *Proof of Parking* plan. The intent of the Proof of Parking plan is to provide documentation on how the site could accommodate all required parking, in the event of ongoing parking problems. Staff are supportive of the proposed parking plan with the exception the 'private drive' sign be removed from the access from the 3rd Street SW Access.

The establishment of this use is not anticipated to adversely impact parking availability in the surrounding area. A condition has been added that any issues due to altered traffic or circulation shall be mitigated by the applicant.

City Code requires all parking be screened from public view. Most parking and internal circulation on the site is screened from public view along Broadway Avenue W and 3rd Street SW, with the exception of the visibility through the access point along Broadway Avenue W.

Landscaping

Landscaping standards are established in City Code Section 153.135. Those requirements are outlined below, with the site perimeter provided by the applicant of 2,030.6.

Overstory Trees:

- Required = 68 (perimeter / 30)
- Proposed = 42 (39 proposed + 3 existing)

Understory Trees/Shrubs:

- Required = 203 (perimeter / 10)
- Proposed = 27

The requirements for overstory trees have since changed since the submission of the application to be less restrictive. Using the updated standards, the application would meet the City landscaping requirement for overstory trees.

The submitted plans still do not depict conformance with City landscaping standards for understory or shrub plantings. Though flexibility was requested by the developer, discussions with the Planning Commission determined additional landscaping would be required onsite. An additional condition of approval was requested by the Planning Commission, asking for an updated landscaping plan to be provided at the time of building permit. The additional landscaping would remove landscaping from the southern site but increase landscaping around the stormwater pond.

Lighting Plan

Lighting standards for commercial and industrial districts are established in City Code Section 153.130(E)(2). The applicant is proposing two new light poles to the east of the proposed structure, within the proposed nursery yard and one new light pole in the southernmost parking island. The proposed location conforms to the City's lighting requirements however the applicant will need to provide evidence installation of the lighting will be shielded from adjacent properties.

Signage

The Applicant has not produced any signage measurements for the noted pylon/monument sign at this time. Staff will need to review any signage for location, size, and conformance with any other design standards at the time signage is proposed to be installed. All signage shall be subject to separate sign permit review at the time of installation, and no flexibility is granted through this PUD approval.

Painted signs are prohibited in the City. The historic EJ Houle Lettering on the side of the grain elevator is legal nonconforming and will not count towards the overall wall sign area on site when reviewing signage for conformance. This is one of very few such signs in the City and cannot be altered to reflect a current commercial message or it would have to receive a variance to come into conformance with current sign requirements.

Stormwater Management

The applicant has proposed a filtration basin on the southwestern portion of the site, to accommodate the increased impervious surface and structures proposed. A stormwater management plan, including runoff rates and volume reduction calculations, was provided for review and approval.

A condition of approval is recommended for conformance to the City Engineer's memo which will provide comments and revisions on the grading and stormwater management plans.

Utilities

The developer shall be responsible for the extension of the watermain south to 1st Avenue SW to the existing watermains, and the abandonment of the existing water and sanitary sewer services. Additionally, the developer, through the lot consolidation process, shall provide a utility easement over the existing watermain on the southeast side of the site. A condition of approval is recommended for conformance to the City Engineer's memo which will provide comments and revisions on the utility and infrastructure improvement plans.

Public Infrastructure Improvements

The City's Downtown Master Plan identifies the need for improvements in downtown Forest Lake supportive of those who bike or walk. In this area, a need is identified for a pedestrian walkway and trail along 2nd Street SW, offsite of the subject property. Thus, trail connectivity through the site will not be required. However, development of a sidewalk bordering the western property line will be required.

Worthy to note for the record, the landowner is not proposed to improve the southern leg of the site at this time. This is something staff has been supportive of as part of this redevelopment project for a couple reasons. First, this area serves as access for an adjacent landowner. In the recent past, City staff have reviewed sketch plans for the development of that parcel. Next, the landowner and City both own property in this area. It is the desire of the City to construct a trailhead in this location some time in the future. Given the (unknown) prospective development in the future, it is in the best interest of all parties to allow this portion of area to remain undeveloped at this time.

Building Design

The building improvements were reviewed against the Design Standards established in City Code Section 153.334. An assessment follows which identifies how staff are interpreting the

conformance of the improvements with adopted requirements. Many of these standards may have become nonconforming over time as the structure was first constructed nearly 100 years before the City adopted its current design standards.

Building Design Requirements

The existing buildings on site have a very distinct architectural style compared to the surrounding downtown Forest Lake. The Houle Feed Mill structure adds variety in terms of style, materials, color, and scale which all contribute to the downtown character. While new structures could not be built in the same manner, or with the same materials, this legal nonconforming style will remain a distinct and unique landmark as the site work is completed.

The proposed building is a commercial greenhouse, with polycarbonate sheets for the sides and roof. The proposed building provides a variation of mass, scale, and height to the site for visual interest and relates to the surrounding buildings on the property. Flexibility is requested for the exterior material and building design elements, as the material proposed is not permitted as an exterior material and the minimum required building design elements are not met.

Staff is generally supportive of the flexibility requested, as the visual interest and use of the building lends to the existing unique style and variety of buildings on the site. However, a condition has been added requiring the applicant to work with City staff to refine the greenhouse design so that its color and materials are compatible with the existing structures on site and surrounding neighborhood.

Review Comments

City Engineer's Comments

Ryan Goodman, City Engineer, provided the City with a review memo dated September 19, 2025, with comments about the project plans dated October 22, 2024. Key comments are summarized below:

- A sidewalk is required along 3rd St. SW.
- A water main extension is required to connect the watermain to 1st Ave SW
- An 30' easement is required to be centered over the watermain running along the SE Corner of the site.

Fire Chief Comments

Fire Chief Newman did not have comments about the proposal.

Building Department Review

Nate Moats, City Building Inspector, reviewed the proposal and provided the following comments related to the proposal:

- Certain piping materials may need to be revised to reflect current standards.

- Building Area summaries are inconsistent on the site plans. More New Building Area is indicated in the Data Summary than appears to be proposed. A full set of construction plans for each new or relocated structure is required.
- Greenhouses over 2000sq ft require fire sprinklers when utilized for display or sale of plants.
- A Met Council SAC Determination is required to be submitted with a building permit.

Public Works Review

Director of Public Works Dave Adams did not have comments on this Development which were not included in the Engineering memo.

Rice Creek Watershed Review

This property is in the Rice Creek Watershed District. The Watershed District has provided a comment on the plans stating that “RCWD has reviewed the construction plans for Spike and Houle’s (RCWD #21-115) and find them acceptable. We will be issuing an Amended Permit for the site.”

Neighborhood Meeting

A neighborhood meeting was held at Forest Lake City Hall on September 24, 2025 at Forest Lake City Hall. The Applicant was present to address questions from property owners from the area surrounding this proposed development. Concerns were raised regarding the lack of fencing around the stormwater pond, increased lighting to adjacent residents, and excess traffic in the Broadway/Lake Street roundabout.

A public hearing notice was posted and mailed in advance of the October 8, 2025, Planning Commission meeting as required by the City’s ordinance and state statute. At the time of writing, no public comments have been received.

Lot Consolidation Request

Section 152.053 of the Forest Lake Zoning Code outlines the requirements and standards for a Lot Consolidation Review in Forest Lake, which are permitted in instances where “two or more parcels, whether recorded platted lots or not, must be consolidated into 1 parcel”. Lot Consolidations are classified as an administrative review process under City code section 152.050 establishing the purpose of Lot Consolidations. The lot consolidation appears to be generally consistent with applicable requirements in City Code. Staff will process the lot consolidation administratively, and approval of the consolidation shall be a condition precedent to approval of the Preliminary/Final PUD.

RECOMMENDATION:

Findings of Fact

Planned Unit Development District (Preliminary and Final)

Section 153.087 of the Forest Lake Zoning Code outlines the requirements and standards for Planned Unit Developments in Forest Lake. In deciding whether to grant a Planned Unit Development, the Planning Commission and City Council must consider the following criteria for general standards as outlined in the Zoning Code. The criteria from the zoning code are listed in **bold**, followed by staff response in *italics*.

- a) **The consistency of the proposed PUD with the city's Comprehensive Plan.**

The proposed use and site plan are consistent with the City's adopted 2040 Comprehensive Plan.

- b) **The proposed use's compliance with the standards and criteria of the zoning code and subdivision regulations.**

The proposed use and site plan will be consistent with the City's adopted zoning ordinance and subdivision regulations with the exceptions noted in this report.

- c) **The extent to which the proposed PUD is designed to form a desirable and unified environment within its own boundaries in terms of relationship of structures, patterns of circulation, visual character, and sufficiency of drainage and utilities.**

The Applicant has designed the proposed PUD to form a desirable and unified environment within the PUD in terms of the relationship of structures, patterns of circulation, visual character, and with sufficient drainage and utilities.

- d) **The extent to which the proposed uses will be compatible with present and planned uses in the surrounding area.**

The proposed uses will be compatible with the present and planned land uses in the surrounding area.

- e) **The impact of the proposed uses on the health, safety, and general welfare of the occupants of the surrounding area.**

The existing and proposed uses in the PUD will not have any negative impacts on the health, safety and general welfare of the surrounding area.

- f) **The burden or impact created by the PUD on parks, schools, streets, and other public facilities and utilities.**

The proposed PUD should not have any negative impact on parks, schools, streets or other public facilities and utilities.

- g) **The sufficiency of each phase of the PUD to ensure its construction and operation is feasible without dependence upon any subsequent phase.**

The Applicant should have sufficient resources to complete and operate this phase of the PUD without any future phase.

- h) **The impact of the PUD on environmental quality, property values, scenic views, and reasonable enjoyment of the surrounding area.**

The proposed PUD should not have any negative impact on environmental quality, property values, scenic views and the reasonable enjoyment of the surrounding area.

- i) **That any exceptions to city code, policy, or regulations are justified by the design or development of the proposed use.**

The proposed exceptions to the City Code included in the proposed PUD, including a reduction in the number of required parking spaces and the building design, are justified by the proposed overall project and building design and the proposed site circulation.

Site Plan Review Request

Section 153.038 of the Forest Lake Zoning Code outlines the requirements and standards for Site Plan Review in Forest Lake, stating the review “will assist the city in achieving safe, functional, and attractive development”.

In deciding whether to grant a Site Plan Review, the Planning Commission and City Council must consider the following criteria for general standards as outlined in the Zoning Code. The criteria from the zoning code are listed in **bold**, followed by staff response in *italics*.

- a) **Consistency with the City Comprehensive Plan.**

The proposed use and site plan are consistent with the City's adopted 2040 Comprehensive Plan.

- b) **Compliance with the Zoning Ordinance.**

The proposed commercial greenhouse and nursery yard accessory uses will be consistent with the City's adopted zoning ordinance standards with the PUD flexibility and conditions as recommended in this report.

- c) **The preservation of the site in its natural state to the extent practicable by minimizing tree loss, soil removal, and grading;**

The proposal will not substantially detract from existing development in the area, and will minimize tree lose, soil removal, and grading as applicable.

- d) **The harmonious relationships between buildings, open spaces, natural site features, architectural details, and vehicular and pedestrian circulations; and**

The proposed plan will be consistent with the City requirements for open space, relationship between buildings, and vehicular and pedestrian circulations.

- e) **The protection of adjacent and neighboring properties.**

City staff does not expect neighboring properties to be adversely impacted by the proposal, as the existing principal use will remain and the overall site will be improved.

Recommended Decision and Conditions

Planning Commission Discussion and Recommendation

The Planning Commission held a public hearing, which has been duly noticed, on this matter on October 8, 2025. After taking testimony on the matter, the Planning Commission unanimously recommended the City Council approve the PUD and Site Plan with the following conditions:

1. Unless as amended by the conditions herein, the final PUD and project plans shall be substantially conforming to the project plans submitted to and reviewed by the Planning Commission on October 8, 2025.
2. The developer shall revise the project plans to reflect all the changes and conditions provided to the City by the City Engineer in a letter dated September 19, 2025. These changes shall be reflected in final plans to be reviewed and approved by the City before the contractor starts any site disturbance.
3. The developer shall work with City staff to provide City drainage and utility, and pedestrian easements. These agreements and easements shall be recorded against the property at Washington County and proof of recording shall be submitted to the City.
4. The developer shall enter into a stormwater maintenance agreement with the City prior to beginning work on site. This agreement shall be recorded against the property at Washington County and proof of recording shall be submitted to the City.
5. The developer shall work with City staff to revise the greenhouse plan to better align the design with the intent of City design requirements.
6. The developer shall work with city staff to revise landscape plans to reduce stormwater pond access and allow flexibility on the southern portions of the site for subsequent development and potential parking
7. No construction or demolition shall occur before the issuance of the required City and Washington County approvals and permitting.
8. The applicant or contractor must obtain all required Washington County and Rice Creek Watershed District, applicable permits before starting any site work.
9. Any public safety issues, as determined by the City, generated due to altered traffic or circulation relating to the use on site shall be mitigated by the applicant at their cost in a manner approved by the City.
10. No additional signage may be located on this site without first receiving the appropriate approvals from the City.
11. Any future alterations to the site or to the exterior façade of the Houle Elevator and Mill Building will require the property owner to obtain required entitlements and permits.
12. Prior to the release of the building permit, the developer shall provide the city with proof of lot combination.
13. At the time of building permit submittal the developer shall submit a lighting plan which conforms to city standards (light cut off at property line).

14. Prior to permit release the developer shall review parking and show proof of parking areas and the developer shall be required to install this additional parking if it is determined by the City parking is a problem in the future.
15. The 3rd Street SW access shall not be marked as private property.

City Council Discussion and Determination

Staff recommend the City Council approve Resolution 01-12-26-08 and Resolution 01-12-26-09, with the recommended 15 conditions from staff and the Planning Commission.

ATTACHMENTS:

Location Map

Project Narrative and Plans

Site Plan

Proof of Parking Plan



Landscape Plan

Greenhouse Design & Photos (6)

Resolution No. 01-08-26-08 – Preliminary and Final PUD

Resolution No. 01-08-26-09 – Site Plan Approval

Legend

-  City Limits
-  Parcels 07/21/2025
-  Lot Lines

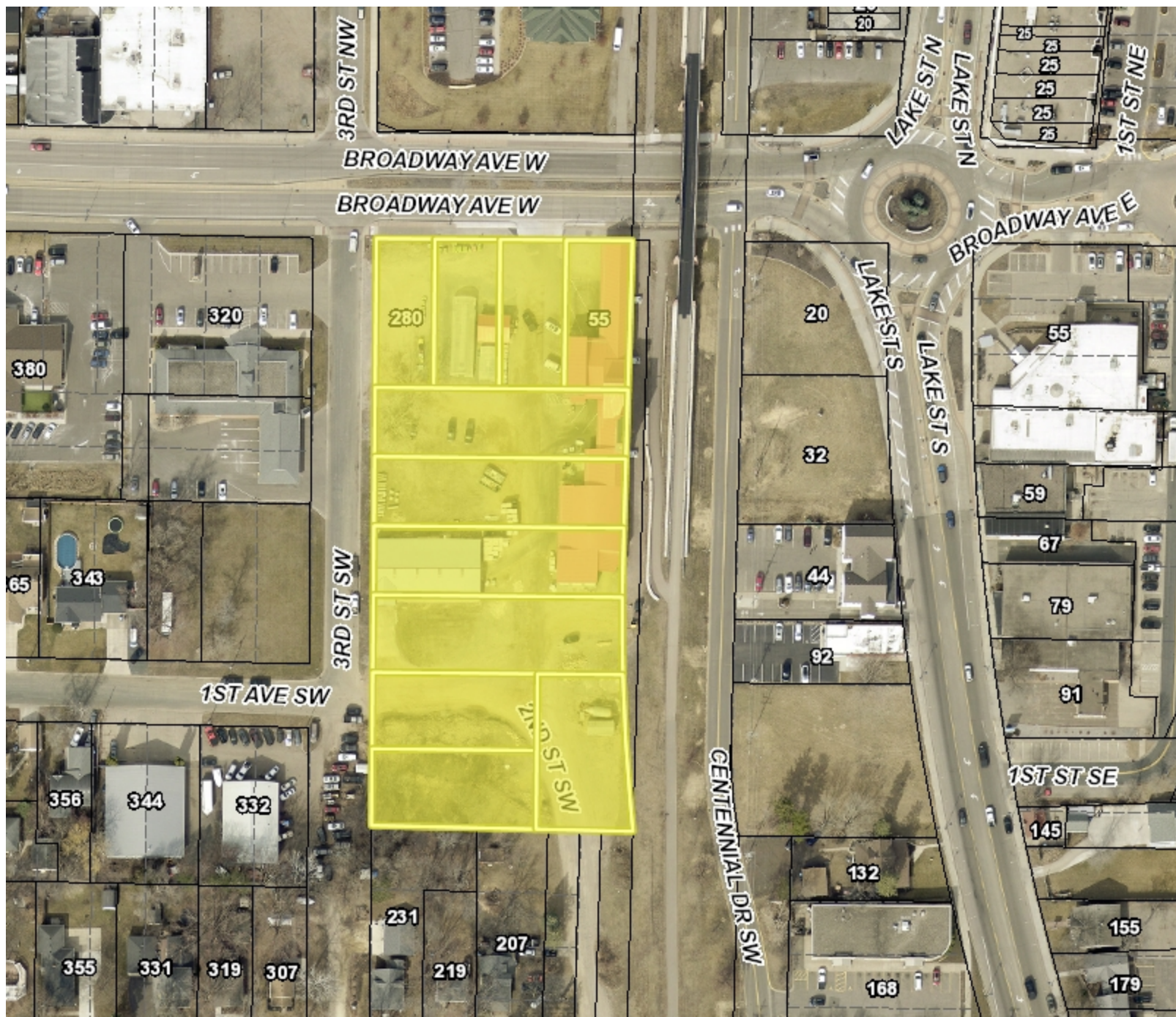

Spikes and Houles
55 2nd St SW



Disclaimer:

This drawing is neither a legally recorded map nor a survey and is not intended to be used as one. This drawing is a compilation of records, information, and data located in various city, county, and state offices, and other sources affecting the area shown, and is to be used for reference purposes only. The City of Forest Lake is not responsible for any inaccuracies herein contained.

0 132 Feet

Spikes & EJ Houles Phase II Project Description

GLG Forest Lake, LLC is applying for approval to update and enhance their current retail site location in Forest Lake.

GLG purchased the historic feed store and property in 2020 from the Houles family. Over the last few years, GLC has made needed renovations to the main building including completely renovating the iconic elevator and adjacent structures. The owners believe in preserving the history of these buildings that have been a part of the community for decades. The Gertens family has built upon the Houles family tradition of serving the community and have expanded their existing product lines which include farm, pet, lawn and nursery supplies.

The proposed expansion would include building an approximate 6,800 SF greenhouse and a nursery yard that would be used primarily for selling perennials, annuals, evergreens, trees and shrubs. A new parking lot with new lighting and enhanced landscaping would also be added along with a storm water pond which would be constructed to provide proper drainage of the site.

The greenhouse covering would be built with Macrolux® Multi Wall Carbonate Sheets and Panels for the roof and walls to let in as much natural sunlight as possible. Pictures of the proposed panels are attached. The floor would be concrete, and irrigation would be accessed from the main building.

GLG believes this will transform this site into a more valuable asset for the community.

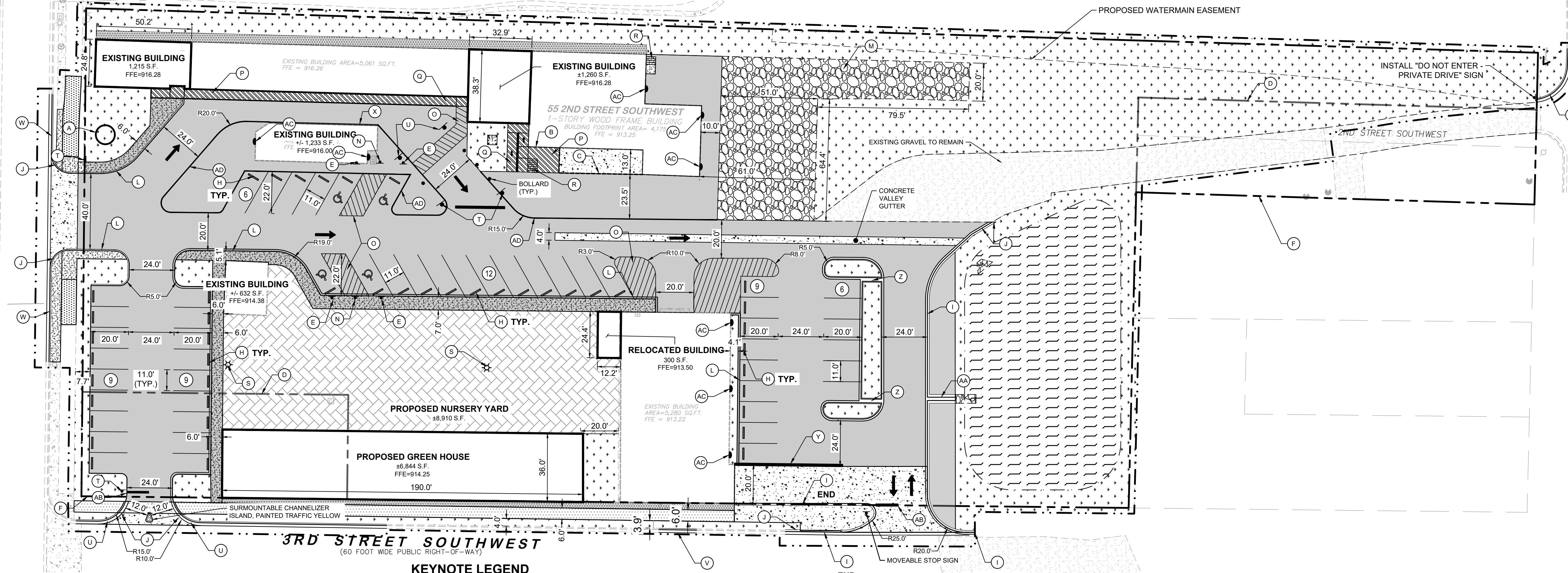

KEYNOTE LEGEND

- (A) RELOCATED SILO
- (B) LOADING DOCK WITH RAMP
- (C) APPROXIMATE LIMITS OF HAY/STRAW STRUCTURE OVERHEAD ROOF LINE
- (D) EXISTING PROPERTY LINE
- (E) ACCESSIBLE PARKING SIGN
- (F) PROPOSED PROPERTY LINE
- (G) PROPOSED WELL, BY OTHERS
- (H) 9' X 6' CONCRETE WHEEL STOP
- (I) SURMOUNTABLE CURB
- (J) TRANSITION CURB
- (K) B612 CURB & GUTTER
- (L) FLUSH CURB
- (M) PROPOSED PALLETIZED BAGGED GOOD STORAGE
- (N) NO PARKING - ACCESS AISLE SIGN
- (O) AREA STRIPED W / 4" SYSL @ 45° 2' O.C.
- (P) PROPOSED PALLETIZED BAGGED GOOD STORAGE
- (Q) ACCESSIBLE RAMP - SEE ARCH PLANS
- (R) PROPOSED STAIRS - SEE ARCH PLANS
- (S) PROPOSED LIGHT POLE
- (T) PROPOSED 30" X 30" STOP SIGN
- (U) PROPOSED YIELD SIGN
- (V) B618 CURB & GUTTER
- (W) B624 CURB & GUTTER
- (X) 6" BARRIER CURB
- (Y) PROPOSED RETAINING WALL
- (Z) 2' WIDE CURB CUT
- (AA) SURMOUNTABLE CONCRETE FLUME
- (AB) STOP BAR
- (AC) PROPOSED WALL PACK
- (AD) 4" SOLID WHITE EDGE STRIPING

LEGEND

- — — — — PROPERTY LINE
- · — · — · — LIMITS OF CONSTRUCTION (OFFSET FOR CLARITY)
- x - x - x - x - x - PROPOSED FENCE
- — — — — SETBACK LINE
- ===== RETAINING WALL
- ===== PROPOSED CURB AND GUTTER
- ===== PROPOSED HEAVY DUTY ASPHALT
- ===== PROPOSED ASPHALT TRAIL
- ===== PROPOSED CONCRETE PAVEMENT
- ===== PROPOSED STORMWATER MANAGEMENT AREA
- ===== PROPOSED SIDEWALK ALTERNATIVES: CONCRETE, ASPHALT, OR PAVERS PER OWNER
- ===== PROPOSED PAVERS
- ===== PROPOSED LANDSCAPING/ PERVIOUS AREA
- ===== PROPOSED PALLETIZED BAGGED GOOD STORAGE
- ===== PROPOSED ROCK MULCH
- ===== PROPOSED DECK (BY OTHERS)

SITE PLAN NOTES

- ALL WORK AND MATERIALS SHALL COMPLY WITH ALL CITY/COUNTY REGULATIONS AND CODES AND O.S.H.A. STANDARDS.
- CONTRACTOR SHALL REFER TO THE ARCHITECTURAL PLANS FOR EXACT LOCATIONS AND DIMENSIONS OF VESTIBULES, SLOPE PAVING, SIDEWALKS, EXIT PORCHES, TRUCK DOCKS, PRECISE BUILDING DIMENSIONS AND EXACT BUILDING UTILITY ENTRANCE LOCATIONS.
- ALL INNER CURBED RADII ARE TO BE 3' AND OUTER CURBED RADII ARE TO BE 10' UNLESS OTHERWISE NOTED. STRIPED RADII ARE TO BE 5'.
- ALL DIMENSIONS AND RADII ARE TO THE FACE OF CURB UNLESS OTHERWISE NOTED.
- EXISTING STRUCTURES WITHIN CONSTRUCTION LIMITS ARE TO BE ABANDONED, REMOVED OR RELOCATED AS NECESSARY. ALL COST SHALL BE INCLUDED IN BASE BID.
- CONTRACTOR SHALL BE RESPONSIBLE FOR ALL RELOCATIONS, (UNLESS OTHERWISE NOTED ON PLANS) INCLUDING BUT NOT LIMITED TO, ALL UTILITIES, STORM DRAINAGE, SIGNS, TRAFFIC SIGNALS & POLES, ETC. AS REQUIRED. ALL WORK SHALL BE IN ACCORDANCE WITH GOVERNING AUTHORITIES REQUIREMENTS AND PROJECT SITE WORK SPECIFICATIONS AND SHALL BE APPROVED BY SUCH. ALL COST SHALL BE INCLUDED IN BASE BID.
- SITE BOUNDARY, TOPOGRAPHY, UTILITY AND ROAD INFORMATION TAKEN FROM A SURVEY BY EGAN, FIELD & NOWAK, INC., DATED 05/08/2020.
KIMLEY-HORN ASSUMES NO LIABILITY FOR ANY ERRORS, INACCURACIES, OR OMISSIONS CONTAINED THEREIN.
- TOTAL LAND AREA IS 3.59 ACRES.
- PYLON / MONUMENT SIGNS SHALL BE CONSTRUCTED BY OTHERS. SIGNS ARE SHOWN FOR GRAPHICAL & INFORMATIONAL PURPOSES ONLY. CONTRACTOR TO VERIFY SIZE, LOCATION AND ANY REQUIRED PERMITS NECESSARY FOR THE CONSTRUCTION OF THE PYLON / MONUMENT SIGN.
- CONTRACTOR SHALL REFERENCE ARCH / MEP PLANS FOR SITE LIGHTING AND ELECTRICAL PLAN.
- NO PROPOSED LANDSCAPING SUCH AS TREES OR SHRUBS, ABOVE AND UNDERGROUND STRUCTURES, OR OTHER OBSTRUCTIONS SHALL BE LOCATED WITHIN EXISTING OR PROPOSED UTILITY EASEMENTS AND RIGHTS OF WAY UNLESS SPECIFICALLY NOTED ON PLANS OTHERWISE.
- REFERENCE ARCHITECTURAL PLANS FOR DUMPSTER ENCLOSURE DETAILS.
- REFER TO FINAL PLAT OR ALTA SURVEY FOR EXACT LOT AND PROPERTY BOUNDARY DIMENSIONS.
- ALL AREAS ARE ROUNDED TO THE NEAREST SQUARE FOOT.
- ALL DIMENSIONS ARE ROUNDED TO THE NEAREST TENTH FOOT.
- ALL PARKING STALLS TO BE 9' IN WIDTH AND 18' IN LENGTH UNLESS OTHERWISE INDICATED.
- CONCRETE TEST POURS REQUIRED WITHIN THE CITY RIGHT OF WAY, INCLUDING COLOR
- STREETS MUST BE PATCHED AT DRIVEWAY ACCESS TO MATCH EXISTING CITY STANDARD PAVEMENT SECTIONS

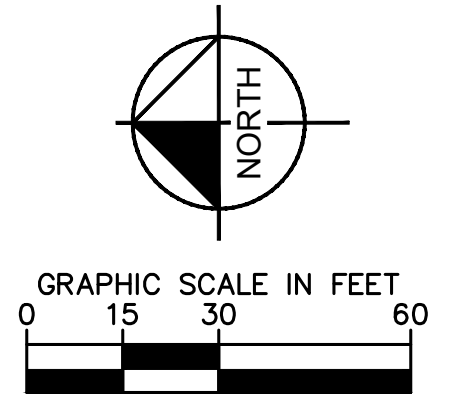

PROPERTY SUMMARY	
SPIKE'S FOREST LAKE	
TOTAL PROPERTY AREA	± 156,168 SF (3.59 AC)
PROPOSED IMPERVIOUS AREA	± 93,493 SF (2.15 AC)
PROPOSED PERVIOUS AREA	± 62,675 SF (1.44 AC)
NEW/RECONSTRUCTED IMPERVIOUS AREA	± 70,108 SF (1.61 AC)
PROPOSED PAVER AREA	± 13,495 SF (0.31 AC)
ZONING SUMMARY	
EXISTING ZONING	MU-1 - DOWNTOWN MIXED USE DISTRICT
PROPOSED ZONING	MU-1 - DOWNTOWN MIXED USE DISTRICT
PARKING SETBACKS	SIDE/REAR = 0' ROAD = 0'
BUILDING SETBACKS	FRONT = 0' SIDE = 0' REAR = 5'

BUILDING DATA SUMMARY	
AREAS	
PROPOSED PROPERTY	± 156,168 SF (3.59 AC)
EXISTING BUILDING AREA TO REMAIN	15,255 SF
NEW BUILDING AREA	9,319 SF
TOTAL BUILDING AREA	± 24,574 SF (15.7% OF TOTAL PROPERTY AREA)
PARKING	
PROPOSED PARKING	51 SPACES
ADA STALLS REQ'D / PROVIDED	3 STALLS / 4 STALLS

SPIKE'S FOREST LAKE

PREPARED FOR
SKYLINE BUILDERS

FOREST LAKE, MN

SITE PLAN

SHEET NUMBER
C400

© 2024 KIMLEY-HORN AND ASSOCIATES, INC.
11995 SINGLETREE LN, SUITE 225, EDEN PRAIRIE, MN 55344
PHONE: 612.315.1272
WWW.KIMLEY-HORN.COM

NO.	REVISIONS	DATE	BY
1	DLI RESUBMITTAL	3/7/2025	BPG
2	CITY RESUBMITTAL	10/18/2024	BPG
3	PERMIT SET	9/13/2024	BPG
4	OWNER REVISIONS	9/5/2023	BPG
5	ISSUE FOR PERMIT	6/22/2023	BPG
6	CITY COMMENTS	6/30/2022	BPG

I HEREBY CERTIFY THAT THIS PLAN, SPECIFICATIONS, AND SCHEDULES WERE PREPARED BY ME OR UNDER MY DIRECT SUPERVISION AND THAT I AM A DULY LICENSED PROFESSIONAL ENGINEER UNDER THE LAWS OF THE STATE OF MINNESOTA.

Brian Garrison
 BRN1767, GANNON
 MN LIC. NO. 59511
 DATE: 10/22/2024

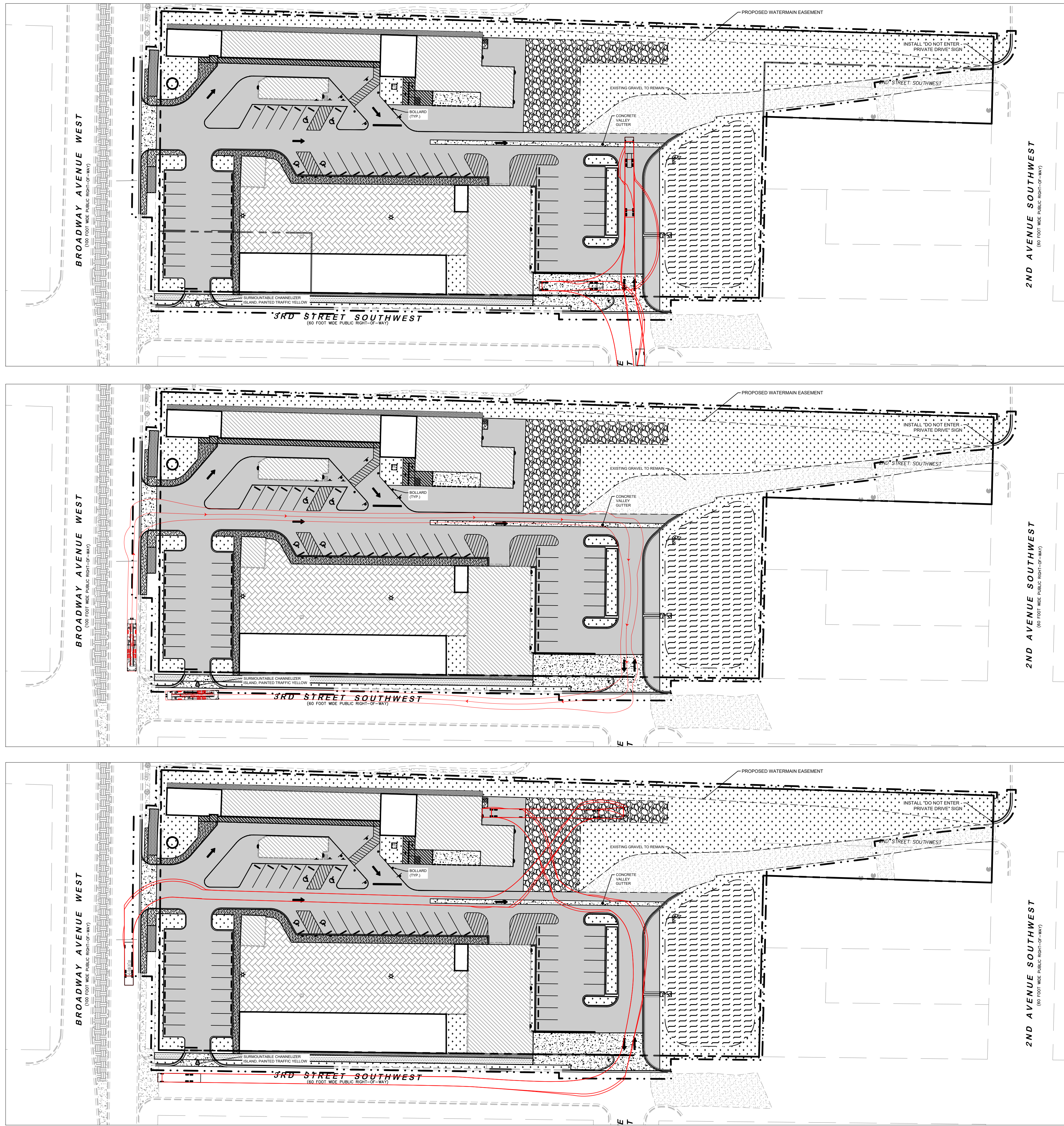

THE VEHICLE MANEUVERING IDENTIFIED ON THIS PLAN WAS PREPARED USING AUTOTURN SOFTWARE AND DOES NOT NECESSARILY REPRESENT ACTUAL CONDITIONS NOR DOES IT ACCOUNT FOR EXTERNAL FACTORS. THIS ANALYSIS SHOULD NOT BE USED AS THE SOLE BASIS FOR THE CLIENT'S DECISION MAKING

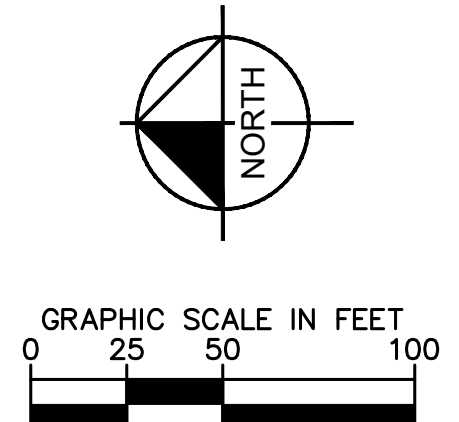
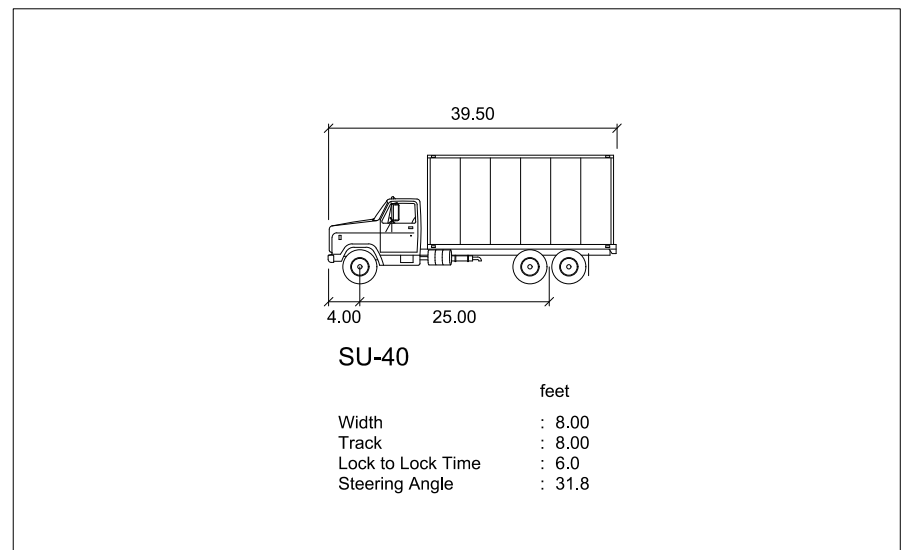
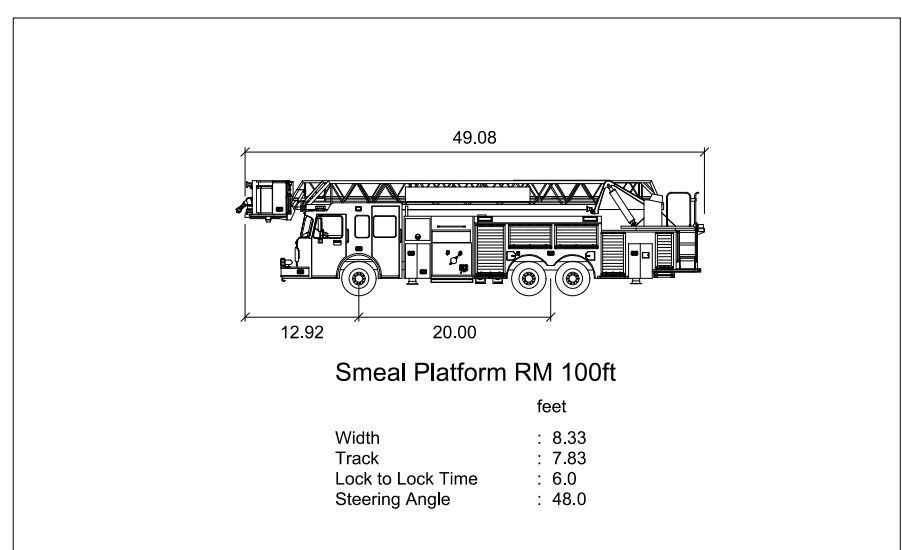
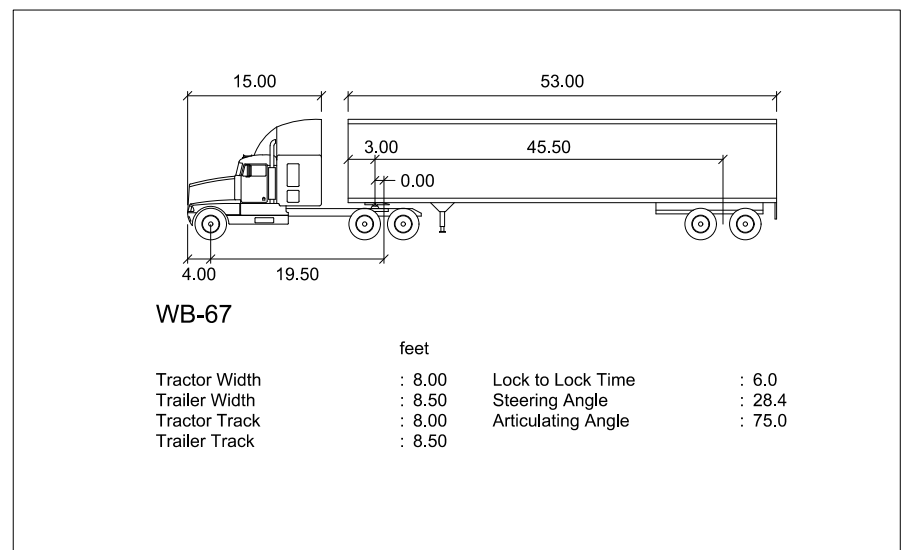

SPIKE'S FOREST LAKE		ACCESS PLAN		FOREST LAKE MN	
PREPARED FOR SKYLINE BUILDERS		KHA PROJECT 160347000		I HEREBY CERTIFY THAT THIS PLAN, PREPARED BY ME OR UNDER MY DIRECT SUPERVISION AND ENGINEER UNDER THE LAWS OF THE STATE OF MINNESOTA, <i>Brian Garrison</i> BRIAN P. GARRISON MINN. LIC. NO. 59511	
SHEET NUMBER C401		DATE 10/22/2024	SCALE AS SHOWN	DESIGNED BY BPG	DRAWN BY CPH
C401		DATE 10/22/2024	CITY COMMENTS	ISSUE FOR PERMIT	OWNER REVISIONS
C401		DATE 6/30/2022	CITY COMMENTS	ISSUE FOR PERMIT	OWNER REVISIONS
C401		DATE 9/5/2023	CITY COMMENTS	ISSUE FOR PERMIT	OWNER REVISIONS
C401		DATE 9/13/2024	CITY COMMENTS	ISSUE FOR PERMIT	OWNER REVISIONS
C401		DATE 10/18/2024	CITY COMMENTS	ISSUE FOR PERMIT	OWNER REVISIONS
C401		DATE 3/7/2025	CITY COMMENTS	ISSUE FOR PERMIT	OWNER REVISIONS

Kimley»Horn
© 2024 KIMLEY-HORN AND ASSOCIATES, INC.
11995 SINGLETREE LN, SUITE 225, EDEN PRAIRIE, MN 55344
PHONE: 612.315.1272
WWW.KIMLEY-HORN.COM

PROOF OF PARKING PLAN

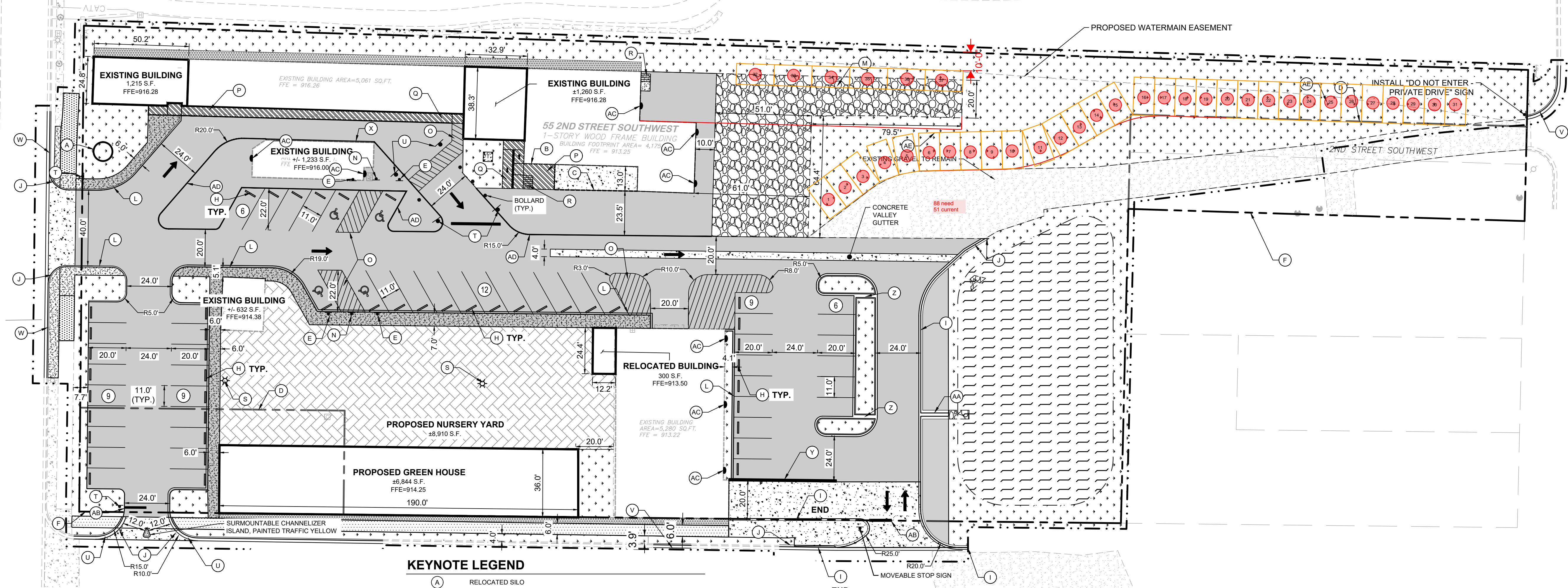

KEYNOTE LEGEND

- (A) RELOCATED SILO
- (B) LOADING DOCK WITH RAMP
- (C) APPROXIMATE LIMITS OF HAY/STRAW STRUCTURE OVERHEAD ROOF LINE
- (D) EXISTING PROPERTY LINE
- (E) ACCESSIBLE PARKING SIGN
- (F) PROPOSED PROPERTY LINE
- (G) PROPOSED WELL, BY OTHERS
- (H) 9' X 6' CONCRETE WHEEL STOP
- (I) SURMOUNTABLE CURB
- (J) TRANSITION CURB
- (K) B612 CURB & GUTTER
- (L) FLUSH CURB
- (M) PROPOSED PALLETIZED BAGGED GOOD STORAGE
- (N) NO PARKING - ACCESS AISLE SIGN
- (O) AREA STRIPED W / 4' SYSL @ 45° 2' O.C.
- (P) PROPOSED PALLETIZED BAGGED GOOD STORAGE
- (Q) ACCESSIBLE RAMP - SEE ARCH PLANS
- (R) PROPOSED STAIRS - SEE ARCH PLANS
- (S) PROPOSED LIGHT POLE
- (T) PROPOSED 30" X 30" STOP SIGN
- (U) PROPOSED YIELD SIGN
- (V) B618 CURB & GUTTER
- (W) B624 CURB & GUTTER
- (X) 6" BARRIER CURB
- (Y) PROPOSED RETAINING WALL
- (Z) 2' WIDE CURB CUT
- (AA) SURMOUNTABLE CONCRETE FLUME
- (AB) STOP BAR
- (AC) PROPOSED WALL PACK
- (AD) 4" SOLID WHITE EDGE STRIPING
- (AE) POOF OF PARKING

LEGEND

- — — — — PROPERTY LINE
- · — · — · — LIMITS OF CONSTRUCTION (OFFSET FOR CLARITY)
- x - x - x - x - x - PROPOSED FENCE
- — — — — SETBACK LINE
- — — — — RETAINING WALL
- — — — — PROPOSED CURB AND GUTTER
- PROPOSED HEAVY DUTY ASPHALT
- PROPOSED ASPHALT TRAIL
- PROPOSED CONCRETE PAVEMENT
- PROPOSED STORMWATER MANAGEMENT AREA
- PROPOSED SIDEWALK ALTERNATIVES: CONCRETE, ASPHALT, OR PAVERS PER OWNER
- PROPOSED PAVERS
- PROPOSED LANDSCAPING/ PERVIOUS AREA
- PROPOSED PALLETIZED BAGGED GOOD STORAGE
- PROPOSED ROCK MULCH
- PROPOSED DECK (BY OTHERS)

SITE PLAN NOTES

- ALL WORK AND MATERIALS SHALL COMPLY WITH ALL CITY/COUNTY REGULATIONS AND CODES AND O.S.H.A. STANDARDS.
- CONTRACTOR SHALL REFER TO THE ARCHITECTURAL PLANS FOR EXACT LOCATIONS AND DIMENSIONS OF VESTIBULES, SLOPE PAVING, SIDEWALKS, EXIT PORCHES, TRUCK DOCKS, PRECISE BUILDING DIMENSIONS AND EXACT BUILDING UTILITY ENTRANCE LOCATIONS.
- ALL INNER CURBED RADII ARE TO BE 3' AND OUTER CURBED RADII ARE TO BE 10' UNLESS OTHERWISE NOTED. STRIPED RADII ARE TO BE 5'.
- ALL DIMENSIONS AND RADII ARE TO THE FACE OF CURB UNLESS OTHERWISE NOTED.
- EXISTING STRUCTURES WITHIN CONSTRUCTION LIMITS ARE TO BE ABANDONED, REMOVED OR RELOCATED AS NECESSARY. ALL COST SHALL BE INCLUDED IN BASE BID.
- CONTRACTOR SHALL BE RESPONSIBLE FOR ALL RELOCATIONS, (UNLESS OTHERWISE NOTED ON PLANS) INCLUDING BUT NOT LIMITED TO, ALL UTILITIES, STORM DRAINAGE, SIGNS, TRAFFIC SIGNALS & POLES, ETC. AS REQUIRED. ALL WORK SHALL BE IN ACCORDANCE WITH GOVERNING AUTHORITIES REQUIREMENTS AND PROJECT SITE WORK SPECIFICATIONS AND SHALL BE APPROVED BY SUCH. ALL COST SHALL BE INCLUDED IN BASE BID.
- SITE BOUNDARY, TOPOGRAPHY, UTILITY AND ROAD INFORMATION TAKEN FROM A SURVEY BY EGAN, FIELD & NOWAK, INC., DATED 05/08/2020.
KIMLEY-HORN ASSUMES NO LIABILITY FOR ANY ERRORS, INACCURACIES, OR OMISSIONS CONTAINED THEREIN.
- TOTAL LAND AREA IS 3.59 ACRES.
- PYLON / MONUMENT SIGNS SHALL BE CONSTRUCTED BY OTHERS. SIGNS ARE SHOWN FOR GRAPHICAL & INFORMATIONAL PURPOSES ONLY. CONTRACTOR TO VERIFY SIZE, LOCATION AND ANY REQUIRED PERMITS NECESSARY FOR THE CONSTRUCTION OF THE PYLON / MONUMENT SIGN.
- CONTRACTOR SHALL REFERENCE ARCH / MEP PLANS FOR SITE LIGHTING AND ELECTRICAL PLAN.
- NO PROPOSED LANDSCAPING SUCH AS TREES OR SHRUBS, ABOVE AND UNDERGROUND STRUCTURES, OR OTHER OBSTRUCTIONS SHALL BE LOCATED WITHIN EXISTING OR PROPOSED UTILITY EASEMENTS AND RIGHTS OF WAY UNLESS SPECIFICALLY NOTED ON PLANS OTHERWISE.
- REFERENCE ARCHITECTURAL PLANS FOR DUMPSTER ENCLOSURE DETAILS.
- REFER TO FINAL PLAT OR ALTA SURVEY FOR EXACT LOT AND PROPERTY BOUNDARY DIMENSIONS.
- ALL AREAS ARE ROUNDED TO THE NEAREST SQUARE FOOT.
- ALL DIMENSIONS ARE ROUNDED TO THE NEAREST TENTH FOOT.
- ALL PARKING STALLS TO BE 9' IN WIDTH AND 18' IN LENGTH UNLESS OTHERWISE INDICATED.
- CONCRETE TEST POURS REQUIRED WITHIN THE CITY RIGHT OF WAY, INCLUDING COLOR
- STREETS MUST BE PATCHED AT DRIVEWAY ACCESS TO MATCH EXISTING CITY STANDARD PAVEMENT SECTIONS

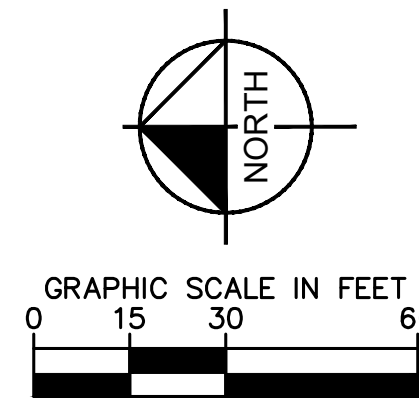

PROPERTY SUMMARY

SPIKE'S FOREST LAKE	
TOTAL PROPERTY AREA	± 156,168 SF (3.59 AC)
PROPOSED IMPERVIOUS AREA	± 93,493 SF (2.15 AC)
PROPOSED PERVIOUS AREA	± 62,675 SF (1.44 AC)
NEW/RECONSTRUCTED IMPERVIOUS AREA	± 70,108 SF (1.61 AC)
PROPOSED PAVER AREA	± 13,495 SF (0.31 AC)
ZONING SUMMARY	
EXISTING ZONING	MU-1 - DOWNTOWN MIXED USE DISTRICT
PROPOSED ZONING	MU-1 - DOWNTOWN MIXED USE DISTRICT
PARKING SETBACKS	SIDE/REAR = 0' ROAD = 0'
BUILDING SETBACKS	FRONT = 0' SIDE = 0' REAR = 5'

BUILDING DATA SUMMARY

AREAS	
PROPOSED PROPERTY	± 156,168 SF (3.59 AC)
EXISTING BUILDING AREA TO REMAIN	15,255 SF
NEW BUILDING AREA	9,319 SF
TOTAL BUILDING AREA	± 24,574 SF (15.7% OF TOTAL PROPERTY AREA)
PARKING	
PROPOSED PARKING	51 SPACES
PROOF OF PARKING	20 SPACES
ADA STALLS REQ'D / PROVIDED	3 STALLS / 4 STALLS

SPIKE'S FOREST LAKE
PREPARED FOR
SKYLINE BUILDERS

SHEET NUMBER
C400

SITE PLAN

I HEREBY CERTIFY THAT THIS PLAN, PREPARED BY ME OR UNDER MY DIRECT SUPERVISION AND AS AN ENGINEER UNDER THE LAWS OF THE STATE OF MINNESOTA.

Brian Garrison
BRIAN P. GARRISON
MINN. LIC. NO. 59511
DATE: 12/01/2025

Kimley»Horn

© 2024 KIMLEY-HORN AND ASSOCIATES, INC.
11995 SINGLETREE LN, SUITE 225, EDEN PRAIRIE, MN 55344
PHONE: 612-315-1272
WWW.KIMLEY-HORN.COM

NO.	REVISIONS	DATE	BY
1	CITY COMMENTS	6/30/2022	BPG
2	ISSUE FOR PERMIT	6/22/2023	BPG
3	OWNER REVISIONS	9/5/2023	BPG
4	PERMIT SET	9/13/2024	BPG
5	CITY RESUBMITTAL	10/18/2024	BPG
6	DLI RESUBMITTAL	3/7/2025	BPG

This document, together with the concepts and designs presented herein, is intended only for the specific purpose and client for which it was prepared. Reuse of and improper reliance on this document without written authorization and adaptation by Kimley-Horn and Associates, Inc. shall be without liability to Kimley-Horn and Associates, Inc.

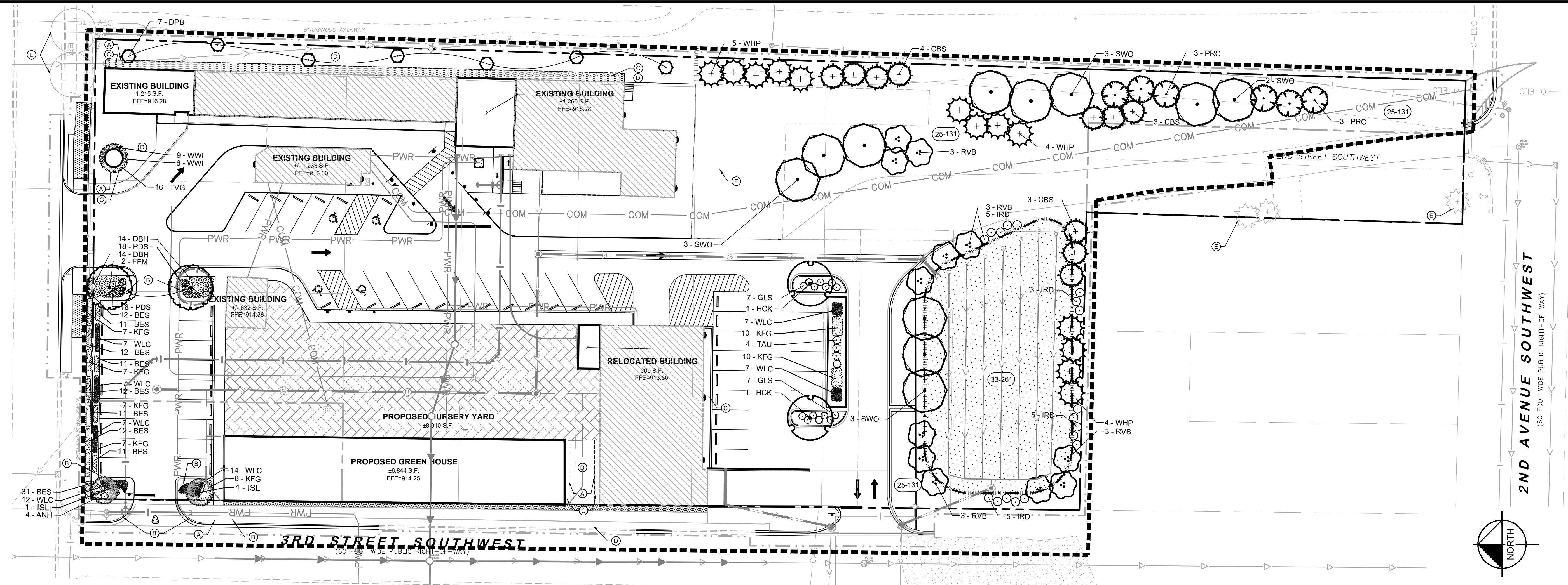

LANDSCAPE LEGEND

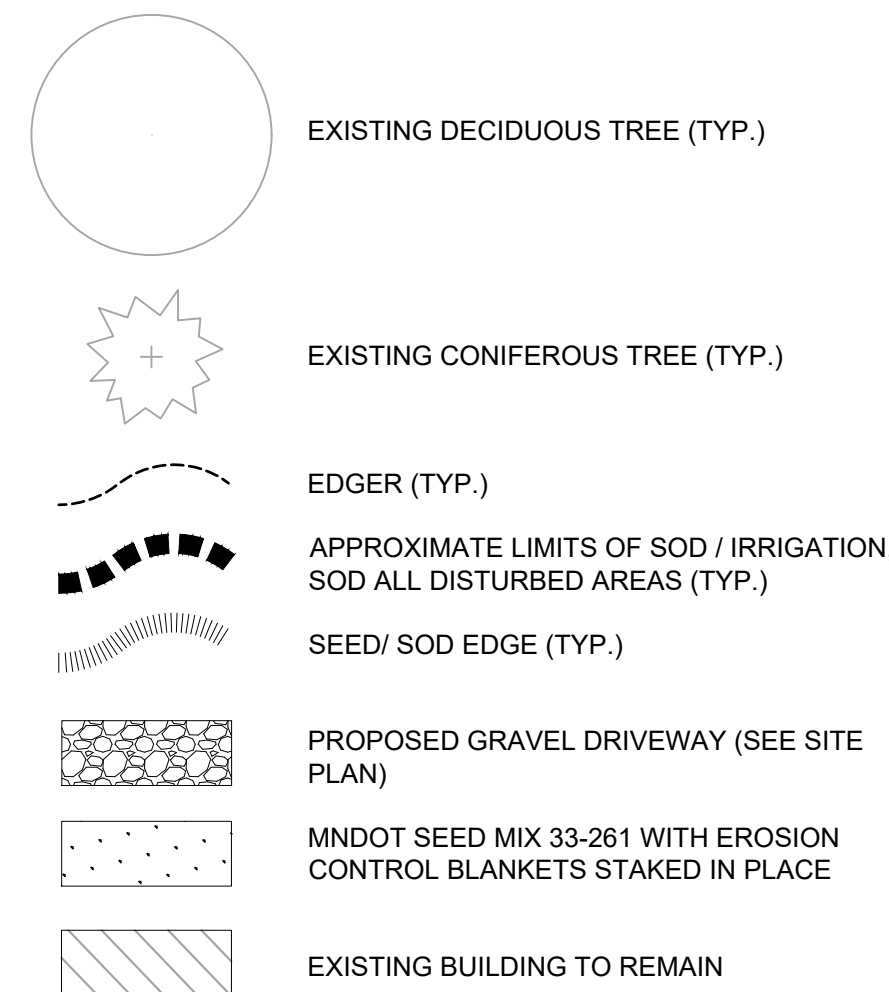

SEEDING KEYNOTES

- (25-131) SEED WITH MNDOT 25-131: LOW MAINTENANCE TURF SEED MIX (TYP.)
 - (33-261) SEED WITH MNDOT 33-261: STORMWATER SOUTH & WEST SEED MIX (TYP.)
- NOTE: ALL SEED MIXES SHALL INCLUDE PROPER EROSION CONTROL FEATURES, WATERING DURING THE ESTABLISHMENT PERIOD AND ONGOING MAINTENANCE PER MANUFACTURER/SUPPLIER SPECIFICATION AND REQUIREMENTS.

LANDSCAPE KEYNOTES

- (A) EDGER (TYP.)
- (B) DOUBLE SHREDDED HARDWOOD MULCH (TYP.)
- (C) ROCK MULCH (TYP.)
- (D) SOD (TYP.)
- (E) EXISTING TREE TO REMAIN (TYP.)
- (F) PROPOSED GRAVEL DRIVEWAY (SEE SITE PLAN)

PLANT SCHEDULE

SYMBOL	CODE	QTY	COMMON NAME	BOTANICAL NAME	CONTAINER	CAL.	SIZE
CONIFEROUS TREE							
(CBS)	CBS	10	COLORADO SPRUCE	PICEA PUNGENS	B & B	6' HT.	6' HT.
(WHP)	WHP	13	WHITE PINE	PINUS STROBUS	B & B	6' HT.	6' HT.
ORNAMENTAL TREE							
(DPB)	DPB	7	DAKOTA PINNACLE BIRCH	BETULA PLATYPHYLLA 'FARGO'	B & B	2" CAL.	
(ISL)	ISL	2	IVORY SILK JAPANESE TREE LILAC	SYRINGA RETICULATA 'IVORY SILK'	B & B	1.5" CAL	
(PRC)	PRC	6	PRAIRIE ROSE CRABAPPLE	MALUS IOENSIS 'PRAIRIE ROSE'	B & B	2" CAL.	
(RVB)	RVB	12	RIVER BIRCH MULTI-TRUNK	BETULA NIGRA	B & B	8' HT.	6' HT.

LANDSCAPE SUMMARY

OVERSTORY TREES REQUIRED: 68 TREES = LOT PERIMETER / 30 = 2030.6 / 30
 OVERSTORY TREES PROVIDED: 42 TREES = 39 PROPOSED + 3 EXISTING

UNDERSTORY TREES REQUIRED: 203 TREES = LOT PERIMETER / 10 = 2030.6 / 10
 UNDERSTORY TREES PROVIDED: 27 TREES

PARKING LOT LANDSCAPING

TREES REQUIRED: 4 TREES = 1 TREE / PARKING LOT ISLAND
 TREES PROVIDED: 1 TREE / 4 ISLANDS

SCREENING REQUIRED: ANY OFF STREET PARKING AREA WITH MORE THAN 6 PARKING SPACES SHALL BE SCREENED WITH A MIX OF SHADE TREES AND UNDERSTORY PLANTINGS IN REQUIRED PARKING LOT SETBACK AREAS SEE PLAN

SCREENING PROVIDED: 1 ROW OF SHADE TREES SPACED AT 15-20 LF OF PARKING EDGE AGAINST A STREET, PARK, OR OTHER PUBLIC OPEN SPACE SEE PLAN

PARKING LOT SCREENING REQUIRED:

PARKING LOT SCREENING PROVIDED:

PLANT SCHEDULE

SYMBOL	CODE	QTY	COMMON NAME	BOTANICAL NAME	CONTAINER	SPACING
(FFM)	FFM	2	FALL FIESTA SUGAR MAPLE	ACER SACCHARUM 'FALL FIESTA'	B & B	2.5" CAL.
(HCK)	HCK	2	COMMON HACKBERRY	CELTIS OCCIDENTALIS	B & B	2.5" CAL.
(SWO)	SWO	12	SWAMP WHITE OAK	QUERCUS BICOLOR	B & B	2.5" CAL.
CONIFEROUS SHRUBS						
(TAU)	TAU	4	TAUNTON YEW	TAXUS X MEDIA 'TAUNTONII'	#5 CONT.	5' O.C.
DECIDUOUS SHRUBS						
(ANH)	ANH	4	ANNABELLE HYDRANGEA	HYDRANGEA ARBORESCENS 'ANNABELLE'	#5 CONT.	4' O.C.
(DBH)	DBH	28	DWARF BUSH HONEYSUCKLE	DIERVILLA LONICERA	#5 CONT.	3' O.C.
(GLS)	GLS	14	GRO-LOW FRAGRANT SUMAC	RHUS AROMATICA 'GRO-LOW'	#5 CONT.	4' O.C.
(IRD)	IRD	18	ISANTI REDOSIER DOGWOOD	CORNUS SERICEA 'ISANTI'	#5 CONT.	5' O.C.
PERENNIALS						
(BES)	BES	123	BLACK-EYED SUSAN	RUDBECKIA FULGIDA 'GOLDSTURM'	#1 CONT	18" O.C.
(KFG)	KFG	56	KARL FOERSTER FEATHER REED GRASS	CALAMAGROSTIS X ACUTIFLORA 'KARL FOERSTER'	#1 CONT	30" O.C.
(PDS)	PDS	36	PRAIRIE DROPSEED	SPOROBOLUS HETEROLEPIS	#1 CONT	24" O.C.
(TVG)	TVG	16	TALL VIOLET GAYFEATHER	LIATRIS SPICATA 'FLORISTAN VIOLET'	#1 CONT.	18" O.C.
(WLC)	WLC	61	WALKERS LOW CATMINT	NEPETA X FAASSENII 'WALKERS LOW'	#1 CONT	30" O.C.
(WWI)	WWI	15	WHITE WILD INDIGO	BAPTISIA ALBA	#1 CONT	24" O.C.

Kimley»Horn

© 2024 KIMLEY-HORN AND ASSOCIATES, INC.
 11995 SINGLETREE LN, SUITE 225, EDEN PRAIRIE, MN 55344
 PHONE: 612.315.1272
 WWW.KIMLEY-HORN.COM

LANDSCAPE PLAN

SPIKE'S FOREST LAKE
 PREPARED FOR SKYLINE BUILDERS
 FOREST LAKE, MN

DATE	REVISIONS
3/7/2025	BPG
10/18/2024	BPG
9/13/2024	BPG
9/5/2023	BPG
6/22/2023	BPG
6/30/2022	BPG

DATE: 10/22/2024
 M.N. LIC. NO.: 53828
 DESIGNED BY: CJK
 DRAWN BY: CJK
 CHECKED BY: RAH

KHA PROJECT: 160347000
 DATE: 10/22/2024
 SCALE: AS SHOWN
 SHEET NUMBER: L100

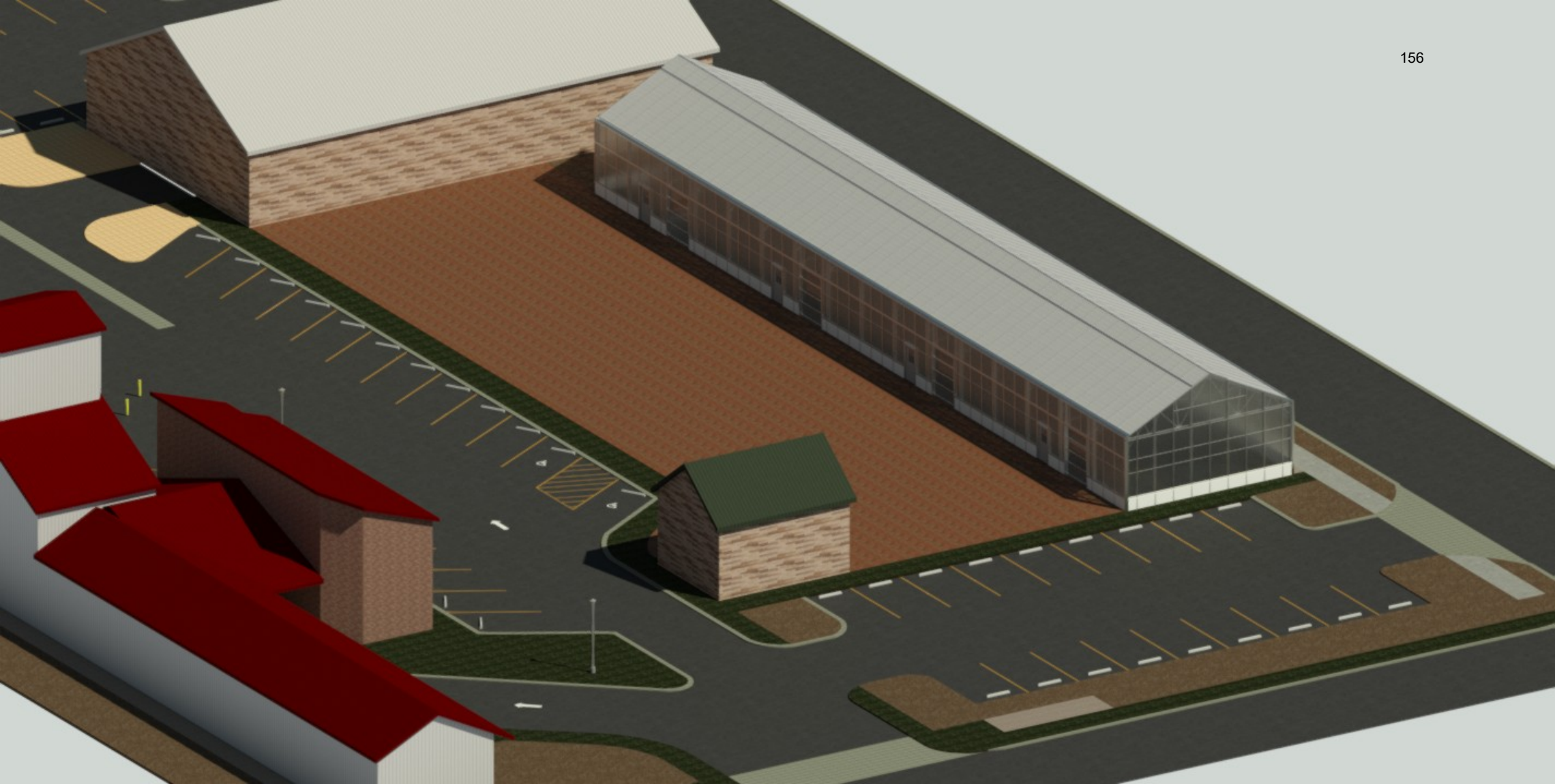











PARKING
VEHICLE ID
REQUIRED
UP TO \$200 FINE
FOR VIOLATION

OUTBACK

**CITY OF FOREST LAKE
WASHINGTON COUNTY, MINNESOTA
RESOLUTION NO. 01-12-26-09**

**A RESOLUTION APPROVING SITE AND DESIGN PLANS FOR THE CONSTRUCTION OF A
COMMERCIAL GREENHOUSE AND NURSERY YARD ON THE PROPERTY LOCATED AT 55 2ND
STREET SW**

WHEREAS, GLG Forest Lake Properties, LLC. (“Owner”) owns the real properties located at 55 2nd Street SW (PID No. 08-032-21-13-0135); 280 Broadway Avenue W (PID No. 08-032-21-12-0132), and PID Nos. 08-032-21-12-0133, 08-032-21-12-0134, 08-032-21-12-0136, 08-032-21-12-0137, 08-032-21-12-0138, 08-032-21-12-0139, 08-032-21-12-0140, 08-032-21-12-0141, and 08-032-21-12-0142, located in the City of Forest Lake, Washington County, Minnesota (“Property”); and

WHEREAS, the applicant GLG Forest Lake Properties, LLC. (“Applicant”), submitted an application and project plans to the City of Forest Lake on July 15, 2025, for site plan review for the construction of an approximately 6,844 square-foot commercial greenhouse and 8,910 square-foot nursery yard on the Property; and

WHEREAS, the legal description of the Property is detailed on **Exhibit A** attached hereto; and

WHEREAS, the requested improvements to the site include the construction 6,844 square-foot commercial greenhouse, a 8,910 square-foot nursery yard, the relocation of a 300 square-foot building, and associated paved drive aisles, parking, and storage areas, as shown in the plans presented to the Planning Commission on October 8, 2025; and

WHEREAS, Staff recommended approval of the site plan review request as further articulated in the City Staff Report dated October 8, 2025, for the October 8, 2025, Planning Commission meeting, attached hereto and incorporated by reference herein as “Staff Report” for the following reasons:

1. The proposed use and site plan are consistent with the City’s adopted 2040 Comprehensive Plan.
2. The proposed commercial greenhouse and nursery yard accessory uses will be consistent with the City’s adopted zoning ordinance standards with the PUD flexibility and conditions as recommended in this report.
3. The proposal will not substantially detract from existing development in the area, and will minimize tree lose, soil removal, and grading as applicable.
4. The proposed plan will be consistent with the City requirements for open space, relationship between buildings, and vehicular and pedestrian circulations.
5. City staff does not expect neighboring properties to be adversely impacted by the proposal, as the existing principal use will remain and the overall site will be improved.

WHEREAS, the Forest Lake Planning Commission (Planning Commission) considered the request at its October 8, 2025, meeting, and reviewed the staff report; and

WHEREAS, the Planning Commission has recommended that the City Council should approve the proposed Site Plan Review to permit the site improvements as described herein and in the Staff Report.

NOW THEREFORE BE IT RESOLVED THAT the City Council of the City of Forest Lake hereby conditionally approves the Site Plan Review for the Property as described herein.

This resolution is adopted by the City Council of the City of Forest Lake this 12th day of January, 2026

Blake Roberts, Mayor

Attest:

Jolleen Chaika, Assistant City Administrator

RESOLUTION NO. 01-08-26-08

EXHIBIT A

Legal Description of Subject Property

**CITY OF FOREST LAKE
WASHINGTON COUNTY, MINNESOTA
RESOLUTION NO. 01-08-26-08**

**A RESOLUTION APPROVING PRELIMINARY AND FINAL PLAN FOR A PUD FOR SPIKE'S AND
HOULES PLANNED UNIT DEVELOPMENT LOCATED AT 55 2ND STREET SW**

WHEREAS, GLG Forest Lake Properties, LLC. (“Applicant”) owns the real properties located at 55 2nd Street SW (PID No. 08-032-21-13-0135); 280 Broadway Avenue W (PID No. 08-032-21-12-0132), and PID Nos. 08-032-21-12-0133, 08-032-21-12-0134, 08-032-21-12-0136, 08-032-21-12-0137, 08-032-21-12-0138, 08-032-21-12-0139, 08-032-21-12-0140, 08-032-21-12-0141, and 08-032-21-12-0142, located in the City of Forest Lake, Washington County, Minnesota (“Property”); and

WHEREAS, the legal description of the Property is detailed on **Exhibit A** attached hereto; and

WHEREAS, the Applicant submitted an application and project plans to the City of Forest Lake on July 15, 2025, for approval of the preliminary and final planned unit development plan for the expansion of an existing retail business on the Property; and

WHEREAS, the Applicant submitted a preliminary and final plan for a PUD to allow for the expansion of the existing retail business to include the construction 6,844 square-foot commercial greenhouse, a 8,910 square-foot nursery yard, the relocation of a 300 square-foot building, and associated paved drive aisles, parking, and storage areas, as shown in the plans presented to the Planning Commission on October 8, 2025; and

WHEREAS, the Applicant has specifically requested the following flexibilities within the Spikes and Houles PUD that are shown in the plans presented to the Planning Commission on October 8, 2025:

1. Deviations from the required building design standards for the proposed commercial greenhouse.
2. To reduce the required landscaping for understory trees on site; and
3. To reduce the number of parking spaces required on site.

WHEREAS, Staff recommended approval of the preliminary and final planned unit development request as further articulated in the City Staff Report dated October 8, 2025, for the October 8, 2025, Planning Commission meeting, attached hereto and incorporated by reference herein as “Staff Report” for the following reasons:

1. The proposed use and site plan are consistent with the City’s adopted 2040 Comprehensive Plan.
2. The proposed use and site plan will be consistent with the City’s adopted zoning ordinance and subdivision regulations with the exceptions noted in this report.
3. The Applicant has designed the proposed PUD to form a desirable and unified environment within the PUD in terms of the relationship of structures, patterns of circulation, visual character, and with sufficient drainage and utilities.
4. The proposed uses will be compatible with the present and planned land uses in the surrounding area.
5. The existing and proposed uses in the PUD will not have any negative impacts on the health, safety and general welfare of the surrounding area.

- 6. The proposed PUD should not have any negative impact on parks, schools, streets or other public facilities and utilities.
- 7. The Applicant should have sufficient resources to complete and operate this phase of the PUD without any future phase.
- 8. The proposed PUD should not have any negative impact on environmental quality, property values, scenic views and the reasonable enjoyment of the surrounding area.
- 9. The proposed exceptions to the City Code included in the proposed PUD, including a reduction in the number of required parking spaces and the building design, are justified by the proposed overall project and building design and the proposed site circulation.

WHEREAS, the Forest Lake Planning Commission (Planning Commission) considered the request at its October 8, 2025, meeting, and reviewed the staff report; and

WHEREAS, the Planning Commission has recommended that the City Council should approve the proposed Preliminary and Final Planned Unit Development as described herein and in the Staff Report.

NOW THEREFORE BE IT RESOLVED THAT the City Council of the City of Forest Lake hereby approves the Preliminary and Final Planned Unit Development for Spikes and Houles for the Property as described herein.

This resolution is adopted by the City Council of the City of Forest Lake this 12th day of January, 2026.

 _ Blake Roberts, Mayor

Attest:

 Jolleen Chaika, Assistant City Administrator

RESOLUTION NO. 01-12-26-09

EXHIBIT A

Legal Description of Subject Property



STAFF REPORT

MEETING DATE: December 3, 2025

STAFF ORIGINATOR: Mark Statz – City Administrator/Airport Manager

AGENDA ITEM: Capital Project Grants - MNDOT

INTRODUCTION: Earlier this year, we were notified by MNDOT that our three grant applications for capital projects had not made the cut to be funded. Those three projects were:

- Apron Expansion
- Main Taxiway Extension (300')
- Runway Extension (300')

However, MNDOT staff assured us that there was a second round of funding yet to come in their fiscal year 2026 that figured to be announced in late September. Although several weeks late, the 2nd round of funding was announced on October 20th and all three of our applications made the “funded” list.

ANALYSIS:

As you may recall, this year’s funding came with a new participation level. Over the past several years, MNDOT had been funding 95% of capital projects. In years prior, that number has been as low as 80%. In FY 2026, the funding level was settled at 90%. This means that the city’s participation level will need to be 10% if we wish to accept the grants awarded to us.

Below is a summary of the project costs, grant allocation and required city match.

Grants	Project Costs	Grant Amount	Local Match
Apron Expansion	\$300,000	\$270,000	\$30,000
Taxiway Extension	\$338,774	\$304,897	\$33,877
Runway Extension	\$1,137,627	\$1,023,864	\$113,763
Total	\$1,612,006	\$1,598,761**	\$177,640

Initially, these grants were anticipated for award in mid-2025 at a 95%/5% split. Therefore, the 2025 airport budget included \$88,820 to fund the projects. The airport budget, however, was budgeted at a deficit of nearly \$23,000. The airport fund balance was projected to be drawn down to just over \$100,000 by the end of 2025, with the unbalanced budget. With the increase in the city's matching requirements, the fund cannot pay for these improvements and sustain itself without help from the general fund.

How the airport should be funded is a complex question. The airport fund has revenue sources assigned to it, including, Agricultural Leases, Land Leases (for Hangars), Fuel Sales Profits, an annual Operations and Maintenance Grant from MNDOT and other miscellaneous incomes. The hangar owners also pay property taxes on their hangars as personal property, much like mobile homes. Last year that totaled around \$15,000. That revenue is not necessarily assigned to the airport fund, but is one way in which the airport contributes to the city's tax base. In rough terms, the airport's operational costs are covered by its operational incomes, if property taxes are included in that analysis (see 2025 projected below).

Revenues	
MNDOT Operating Grant	\$18,526.00
Hangar Land Lease	\$29,383.25
Ag Leases	\$13,900.00
Fuel Sales	\$50,000.00
Interest Earnings	\$2,500.00
Property Taxes (Hangars)	\$15,424.34
	\$129,733.59
Expenses	
Wages/Benefits	\$50,000.00
Fuel	\$40,000.00
Professional Services	\$15,800.00
Utilities	\$6,664.00
Maintenance & Repair	\$14,100.00
Insurance	\$3,150.00
	\$129,714.00
Operating Income (Deficit)	\$19.59

The tougher question is how to fund capital expenses. While capital improvements certainly benefit hangar owners, they also represent a long-term investment in a city-owned asset. Hangar lot leases do not explicitly discuss the participation by hangar owners in the cost of such infrastructure. Past attempts to have hangar owners share in the cost of capital improvements has been met with some resistance. However, the vast majority of owners did pay the associated fees imposed.

Staff believes that the proposed improvements to the airport will increase interest from those who wish to build a new hangar. Additional hangars will mean additional revenues and these funds will help to offset the initial investments made by the city.

The Airport Commission voted to recommend the acceptance of all three MNDOT grants at their last meeting, in December.

RECOMMENDATION: Motion to accept all three grants from MNDOT, totaling \$1,598,761, award the contract for the construction of the taxiway and runway project to Forest Lake Contracting and fund the projects through the city's Capital Improvement Fund (Street Fund).

ATTACHMENTS: Grant Offer Letters, Maps

U:\\$H Drive Data\Airports\Airport CIP - Grant\FRLK\Forest Lake SFY 26(SFY_26\CAD\25D-APRON EXPANSION_LAYOUT_112425.dwg 11/24/2025 11:41:06 AM



U:\\$H Drive Data\Airports\Airport CIP - Grant\FRLK\Forest Lake SFY 26\SFY_26\CAD\25D_RUNWAY_EXPANSION_LAYOUT_11/25/2025 2:13:35 PM

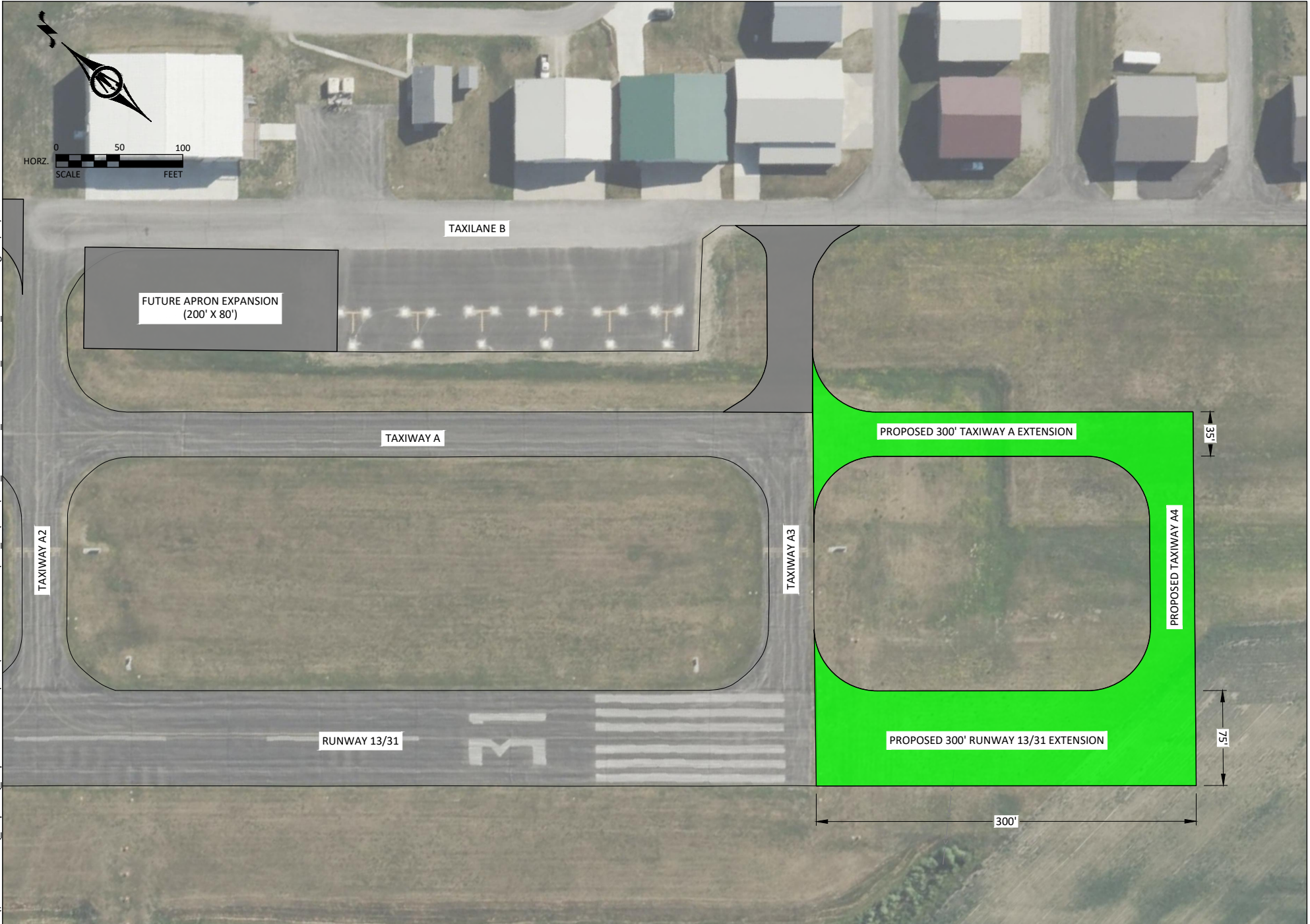

October 17, 2025

Mark Statz

City Administrator

Forest Lake

Subject: State Fiscal Year 2026 Capital Grant Award Notification – 2nd Round Offer

Dear Mark Statz,

The Minnesota Department of Transportation (MnDOT) Office of Aeronautics has completed its review and prioritization of funding requests submitted during the State Fiscal Year (SFY) 2026 Capital Grant solicitation.

We are pleased to inform you that the **Apron Expansion - 200' x 80'** project, with a total cost of **\$300,000**, has been selected to receive a State Grant Offer. MnDOT will proceed with executing a grant contract under the following conditions:

Grant Conditions

- **Project-Specific Funding:** The awarded funds are designated specifically for the project named above and may not be transferred to another project at your airport.
- **Grant Execution Period:**
The awarded funds must be encumbered during SFY 2026 (July 1, 2025 – June 30, 2026). To ensure timely use of State Airports Fund resources:
 - You must notify MnDOT of your **intent to pursue this grant no later than November 14, 2025**.
 - A **complete grant request** must be submitted by **December 19, 2025**.
 - If a complete request is not submitted by December 19th and no extension is approved, the project will be removed from consideration for SFY 2026 funding, funds will then be reprogrammed to support other airport needs, and the project would have to be resubmitted for prioritization during the next fiscal year's solicitation.

Required for a Complete Grant Request

Please submit the following documents by email to airportdevelopment@state.mn.us:

- A **Grant Request Letter** on sponsor letterhead identifying the project and requested funding.
- A **Project Cost Split** in Excel format. A template is available at: <http://www.dot.state.mn.us/aero/airportdevelopment/forms.html>
- Any supporting documentation outlining project costs (e.g., bid tabs, consultant agreements).
- MnDOT may request additional clarification or documents as needed.

Next Steps and Reimbursement Details

- Once MnDOT receives and approves your complete request, we will encumber the funds and prepare a grant contract for signature.
- **No reimbursement** will be made until a **fully executed grant contract** is in place.
- If early work is necessary, you may consult your Regional Engineer about proceeding through the **Early Encumbrance process**. Be aware:
 - Costs incurred **before encumbrance** are not eligible for reimbursement.
 - Costs incurred **after encumbrance but before grant execution** may be eligible—**but only reimbursed after** full contract execution.
 - Early Encumbrance is at your own risk and does not guarantee funding until a signed contract is in place.

Key Deadlines Summary

1. **November 14, 2025** – Confirm your intent to proceed with the project.
2. **December 19, 2025** – Submit a complete grant request or coordinate an alternate deadline with your Regional Engineer.
3. **December 20, 2025** – If no grant request is received and no extension approved, the project will be removed from consideration, and you must reapply in the next solicitation round.

If you no longer intend to pursue this project for SFY 2026, please notify me as soon as possible so the funds may be reallocated. If you have any questions or need assistance, don't hesitate to contact me directly.

Sincerely,

Jason Radde, P.E.

Central Region Engineer

Minnesota Department of Transportation – Office of Aeronautics

Central Region Engineer

CC: Silas Parmar, silas.parmar@bolton-menk.com

Equal Opportunity Employer

October 17, 2025

Mark Statz

City Administrator

Forest Lake

Subject: State Fiscal Year 2026 Capital Grant Award Notification – 2nd Round Offer

Dear Mark Statz,

The Minnesota Department of Transportation (MnDOT) Office of Aeronautics has completed its review and prioritization of funding requests submitted during the State Fiscal Year (SFY) 2026 Capital Grant solicitation.

We are pleased to inform you that the **Taxiway A Extension - 300 Feet** project, with a total cost of **\$338,774**, has been selected to receive a State Grant Offer. MnDOT will proceed with executing a grant contract under the following conditions:

Grant Conditions

- **Project-Specific Funding:** The awarded funds are designated specifically for the project named above and may not be transferred to another project at your airport.
- **Grant Execution Period:**
The awarded funds must be encumbered during SFY 2026 (July 1, 2025 – June 30, 2026). To ensure timely use of State Airports Fund resources:
 - You must notify MnDOT of your **intent to pursue this grant no later than November 14, 2025**.
 - A **complete grant request** must be submitted by **December 19, 2025**.
 - If a complete request is not submitted by December 19th and no extension is approved, the project will be removed from consideration for SFY 2026 funding, funds will then be reprogrammed to support other airport needs, and the project would have to be resubmitted for prioritization during the next fiscal year's solicitation.

Required for a Complete Grant Request

Please submit the following documents by email to airportdevelopment@state.mn.us:

- A **Grant Request Letter** on sponsor letterhead identifying the project and requested funding.
- A **Project Cost Split** in Excel format. A template is available at: <http://www.dot.state.mn.us/aero/airportdevelopment/forms.html>
- Any supporting documentation outlining project costs (e.g., bid tabs, consultant agreements).
- MnDOT may request additional clarification or documents as needed.

Next Steps and Reimbursement Details

- Once MnDOT receives and approves your complete request, we will encumber the funds and prepare a grant contract for signature.
- **No reimbursement** will be made until a **fully executed grant contract** is in place.
- If early work is necessary, you may consult your Regional Engineer about proceeding through the **Early Encumbrance process**. Be aware:
 - Costs incurred **before encumbrance** are not eligible for reimbursement.
 - Costs incurred **after encumbrance but before grant execution** may be eligible—**but only reimbursed after** full contract execution.
 - Early Encumbrance is at your own risk and does not guarantee funding until a signed contract is in place.

Key Deadlines Summary

1. **November 14, 2025** – Confirm your intent to proceed with the project.
2. **December 19, 2025** – Submit a complete grant request or coordinate an alternate deadline with your Regional Engineer.
3. **December 20, 2025** – If no grant request is received and no extension approved, the project will be removed from consideration, and you must reapply in the next solicitation round.

If you no longer intend to pursue this project for SFY 2026, please notify me as soon as possible so the funds may be reallocated. If you have any questions or need assistance, don't hesitate to contact me directly.

Sincerely,

Jason Radde, P.E.

Central Region Engineer

Minnesota Department of Transportation – Office of Aeronautics

Central Region Engineer

CC: Silas Parmar, silas.parmar@bolton-menk.com

Equal Opportunity Employer

October 17, 2025

Mark Statz

City Administrator

Forest Lake

Subject: State Fiscal Year 2026 Capital Grant Award Notification – 2nd Round Offer

Dear Mark Statz,

The Minnesota Department of Transportation (MnDOT) Office of Aeronautics has completed its review and prioritization of funding requests submitted during the State Fiscal Year (SFY) 2026 Capital Grant solicitation.

We are pleased to inform you that the **Runway 13/31 Extension - 300 feet** project, with a total cost of **\$1,137,627**, has been selected to receive a State Grant Offer. MnDOT will proceed with executing a grant contract under the following conditions:

Grant Conditions

- **Project-Specific Funding:** The awarded funds are designated specifically for the project named above and may not be transferred to another project at your airport.
- **Grant Execution Period:**
The awarded funds must be encumbered during SFY 2026 (July 1, 2025 – June 30, 2026). To ensure timely use of State Airports Fund resources:
 - You must notify MnDOT of your **intent to pursue this grant no later than November 14, 2025**.
 - A **complete grant request** must be submitted by **December 19, 2025**.
 - If a complete request is not submitted by December 19th and no extension is approved, the project will be removed from consideration for SFY 2026 funding, funds will then be reprogrammed to support other airport needs, and the project would have to be resubmitted for prioritization during the next fiscal year's solicitation.

Required for a Complete Grant Request

Please submit the following documents by email to airportdevelopment@state.mn.us:

- A **Grant Request Letter** on sponsor letterhead identifying the project and requested funding.
- A **Project Cost Split** in Excel format. A template is available at: <http://www.dot.state.mn.us/aero/airportdevelopment/forms.html>
- Any supporting documentation outlining project costs (e.g., bid tabs, consultant agreements).
- MnDOT may request additional clarification or documents as needed.

Next Steps and Reimbursement Details

- Once MnDOT receives and approves your complete request, we will encumber the funds and prepare a grant contract for signature.
- **No reimbursement** will be made until a **fully executed grant contract** is in place.
- If early work is necessary, you may consult your Regional Engineer about proceeding through the **Early Encumbrance process**. Be aware:
 - Costs incurred **before encumbrance** are not eligible for reimbursement.
 - Costs incurred **after encumbrance but before grant execution** may be eligible—**but only reimbursed after** full contract execution.
 - Early Encumbrance is at your own risk and does not guarantee funding until a signed contract is in place.

Key Deadlines Summary

1. **November 14, 2025** – Confirm your intent to proceed with the project.
2. **December 19, 2025** – Submit a complete grant request or coordinate an alternate deadline with your Regional Engineer.
3. **December 20, 2025** – If no grant request is received and no extension approved, the project will be removed from consideration, and you must reapply in the next solicitation round.

If you no longer intend to pursue this project for SFY 2026, please notify me as soon as possible so the funds may be reallocated. If you have any questions or need assistance, don't hesitate to contact me directly.

Sincerely,

Jason Radde, P.E.

Central Region Engineer

Minnesota Department of Transportation – Office of Aeronautics

Central Region Engineer

CC: Silas Parmar, silas.parmar@bolton-menk.com

Equal Opportunity Employer



October 31, 2025

Mr. Ryan Gaug
Director
MnDOT Office of Aeronautics
395 John Ireland Boulevard
St. Paul, MN 55155

RE: Forest Lake Airport (25D)
Request for Exception to \$1 million SAF Cap

Dear Mr. Gaug:

The city of Forest Lake, MN respectfully requests an exception to the \$1 million State Aeronautics Funding (SAF) cap for State Fiscal Year 2026 for the following projects:

- Runway 13/31 300-foot Extension - Construction
- Taxiway A 300-foot Extension - Construction
- Apron Expansion (200-feet by 80-feet) – Design and Construction

In State FY 2025, the City received a State grant (A8206-28) for Design and Bid Administration services for the Runway and Taxiway Extension projects. Preliminary engineer estimates shared with MnDOT Aeronautics personnel identified a total construction cost of \$1,476,401. The preliminary engineer estimate for the Apron Expansion project identified a total project cost of \$300,000.

Bids for the Runway and Taxiway Extension projects were opened on June 18, 2025 with the actual total construction cost of \$1,297,006. Including the estimated total cost for the Apron Expansion project, the City is requesting \$1,437,305.40 in SAF funding for SFY 26.

We appreciate MnDOT's continued support of the Forest Lake Airport and your consideration of the \$1 million of SAF cap exception. If you have any questions or shall require additional information, please contact me at (651) 209-9750 or mark.statz@ci.forest-lake.mn.us.

Sincerely,

Mark Statz, P.E.
City Administrator

cc: Kirby Becker, MnDOT
Arika Johnson, MnDOT
Jason Radde, MnDOT
Silas Parmar, Bolton & Menk, Inc.

STAFF REPORT



MEETING DATE: January 12, 2025
TO: Honorable Mayor and City Council
STAFF ORIGINATOR: Dave Adams, Public Works Director
AGENDA ITEM: City Logo on Street Name Signs

INTRODUCTION:

The City of Forest Lake began replacing all traffic signs, including street name blades, on a 10-year cycle beginning in 2016 to ensure compliance with visibility and safety standards. Several years ago, the City Council expressed interest in adding the City logo to street name signs. At that time, staff recommended waiting until the next replacement cycle to implement this change for efficiency and cost-effectiveness. We are now entering that cycle, making this the ideal time to incorporate the logo.

ANALYSIS:

Incorporating the City logo into street name signs during the scheduled 10-year replacement cycle provides several benefits. Aligning this change with the existing program ensures cost efficiency by avoiding additional labor or material expenses outside of routine maintenance. The addition of the logo will enhance the City's branding and visual identity, creating a consistent and professional appearance across public infrastructure while promoting civic pride.

To support this initiative, staff has prepared five logo variations for consideration. Each option meets MUTCD standards for size, reflectivity, and placement, ensuring that traffic safety and readability are not compromised. The primary differences between the options relate to color, complexity, and branding style.

The incremental cost of adding the logo to each sign is minimal and can be absorbed within the current budget for sign replacement. Overall, this timing and approach allow the City to achieve its branding goals efficiently and responsibly.

RECOMMENDATION:

Staff recommends that the City Council decide on incorporating the official City of Forest Lake logo on all street name signs as part of the upcoming 10-year replacement cycle. If a logo is decided, the City Council is asked to select one of four proposed logo options, which are presented as actual street sign mock-ups to show how each logo will appear on the finished signs.

City Council **“Make a motion to not include logos on all street name signs”**

-or-

City Council **“Make a motion to include Option ___ logo on all street name signs.”**

ATTACHMENTS:

Street Sign Blade Options

1



2



3



4



5



48 in